

Jyrki Savolainen

## **ANALYZING THE PROFITABILITY OF METAL MINING INVESTMENTS WITH SYSTEM DYNAMIC MODELING AND REAL OPTION ANALYSIS**

Thesis for the degree of Doctor of Science (Economics and Business Administration) to be presented with due permission for public examination and criticism in the Auditorium of the Student Union House at Lappeenranta University of Technology, Lappeenranta, Finland on the 17<sup>th</sup> of December, 2016, at noon.

Acta Universitatis  
Lappeenrantaensis 731

Supervisors Professor Mikael Collan  
LUT School of Business and Management  
Lappeenranta University of Technology  
Finland

Professor Heikki Haario  
LUT School of Engineering Science  
Lappeenranta University of Technology  
Finland

Reviewers Professor Yuri Lawryshyn  
Faculty of Applied Science and Engineering  
University of Toronto  
Canada

Professor Stein-Erik Fleten  
Faculty of Social Sciences and Technology Management  
Norwegian University of Science and Technology  
Norway

Opponent Professor Yuri Lawryshyn  
Faculty of Applied Science and Engineering  
University of Toronto  
Canada

ISBN 978-952-335-040-3  
ISBN 978-952-335-041-0 (PDF)  
ISSN-L 1456-4491  
ISSN 1456-4491

Lappeenrannan teknillinen yliopisto  
Yliopistopaino 2016

## **Abstract**

**Jyrki Savolainen**

**Analyzing the profitability of metal mining investments with system dynamic modeling and real option analysis**

Lappeenranta 2016

64 pages + publications

Acta Universitatis Lappeenrantaensis 731

Diss. Lappeenranta University of Technology

ISBN 978-952-335-040-3, ISBN 978-952-335-041-0 (PDF),

ISSN-L 1456-4491, ISSN 1456-4491

The importance of ex-ante analysis of metal mining investments has grown in recent years. The decreasing profitability of new projects and unpredictable metal markets pose a challenge to the currently applied models of profitability analysis. The purpose of this research is to investigate simulation and system dynamic (SD) models applicable to real option analysis of metal mining investments. Real options in general refer to flexibility of projects which can both decrease the negative effects of uncertainty and, on the other hand, enhance the positive future realizations of the projects. This thesis is a collection of articles with common theme of enhancing the simulation- and SD-models used for real option valuation of metal mining investments.

Within the framework of real option analysis it is claimed that metal mining investments are a distinct object of study, which have specific characteristics that should be taken into account in their real option analysis. The research methods of this thesis include literature review and modeling. Two distinct simulation models are created: a system dynamic simulation model and a static simulation model. The models are used to run analyses with illustrative case examples that have their background in the metal mining industry.

The results suggest that metal mining investments can be treated as techno-economic systems by using the SD-methodology and that the use of system dynamic simulation based analysis allows a more detailed and realistic ex-ante modeling of metal mining investments and of the connected uncertainties. It is shown that system dynamic models are able to model compound and interacting real options that exist on a single asset. Based on the results of this work it seems that under non-ideal conditions the profitability of metal mining investments is linked to the financing of these projects. High leverage with a fixed debt servicing schedule may inhibit the use of managerial flexibility that may cause a loss of project value. It is suggested that an optimal debt-equity ratio exists that maximizes the project value per percentage point of equity invested.

**Keywords:** Investment analysis, Simulation, Metal mining, Real options, System dynamics



## **Acknowledgements**

This work was carried out in the School of Business and at Lappeenranta University of Technology, Finland, between September 2014 and August 2016.

I owe my deepest gratitude to my supervisor Professor Mikael Collan who put his time and effort in this research and served as my mentor in the academic world. I wish to thank Professor Heikki Haario and Doctor Jaana Lappalainen for encouraging me to apply for doctoral studies. I also want to thank my co-author and second supervisor Professor Pasi Luukka for support. Thanks to Professor Kalevi Kyläheiko for his contribution to this research. I am thankful for Professor Yuri Lawryshyn and Professor Stein-Erik Fleten for their constructive reviews on the final thesis.

Special thanks to the people of Talvivaara Sotkamo / Talvivaara Mining Company for endless discussions about the profitability of metals mining. The original ideas of this work lie in those discussions.

I am grateful for the financial support received from the following Finnish organizations:

The Education Fund  
The Jenny and Antti Wihuri Foundation  
Research Foundation of Lappeenranta University of Technology  
Kainuu Regional Fund (Finnish Cultural Foundation)  
Foundation for Economic Education.

Finally, my dear wife, Anna, thank you for the patience, support and understanding.

Jyrki Savolainen  
August 2016  
Kajaani, Finland



# Contents

<b>Abstract</b>	<b>3</b>
<b>Acknowledgements</b>	<b>5</b>
<b>Contents</b>	<b>7</b>
<b>List of publications</b>	<b>9</b>
<b>List of abbreviations</b>	<b>11</b>
<b>1 Introduction</b>	<b>13</b>
1.1 Background and motivation .....	13
1.2 The focus of this research.....	15
1.3 Objectives of this research and connected questions .....	17
1.4 Outline of the thesis.....	18
<b>2 Theoretical background</b>	<b>19</b>
2.1 Methodology framework.....	19
2.2 Philosophical position of the research.....	20
2.2.1 On uncertainty and probability .....	21
2.2.2 On simulation models in quantitative operations management research .....	22
2.3 State of the art of profitability analysis in metal mining .....	23
2.4 Real options in the metal mining industry.....	26
2.5 System dynamics.....	29
2.6 Monte Carlo simulation.....	31
2.7 Probability distributions and stochastic differential equations in representing uncertainty.....	31
2.7.1 Stochastic differential equation models for metal markets and expert judgment.....	33
<b>3 The models created in this research</b>	<b>35</b>
3.1 System dynamic model of a metal mining investment.....	36
3.2 The static simulation model for metal mining investments .....	42
<b>4 The publications and a review of the results</b>	<b>45</b>
4.1 Publication 1: Real options in metal mining project valuation: review of literature .....	45
4.2 Publication 2: Using a cycle reverting price process in modeling metal mining project profitability.....	46
4.3 Publication 3: Modeling the Profitability of Metal Mining Investments with Real Options as a Dynamic Techno-Economic System.....	46
4.4 Publication 4: Analyzing operational real options in metal mining investments with a system dynamic model .....	47

4.5	Publication 5: Combining system dynamic modeling and the Datar-Mathews method for analyzing metal mine investments .....	47
4.6	Publication 6: On the trade-off between the leverage effect and real options thinking: a simulation-based model on metal mining investment .....	48
4.7	Summary of publications 1-6 .....	48
<b>5</b>	<b>Discussion and conclusions</b>	<b>51</b>
5.1	Answering the research questions .....	51
5.2	Managerial and policy implications .....	53
5.3	Limitations of the research .....	53
5.4	Suggestions for future research .....	54
	<b>References</b>	<b>55</b>



## List of publications

This thesis is based on the following papers with a summary of the author's contribution. The rights have been granted by publishers to include the papers in dissertation.

- I. Savolainen, J. (2016). Real options in metal mining project valuation: review of literature. *Resources Policy* 50, pp. 49-65.
- II. Savolainen, J., Collan, M. and Luukka, P. (n.d.). Using a cycle reverting price process in modeling metal mining project profitability. *Kybernetes*. Article in press.
- III. Savolainen, J., Collan, M., Luukka, P., (2016). Modeling the Profitability of Metal Mining Investments with Real Options as a Dynamic Techno-Economic System, in: Merkel, E., Kunze, R., Fichtner, W. (Eds.), *Einsatz von OR-Verfahren Zur Analyse von Fragestellungen Im Umweltbereich. Tagungsband Zu Den Workshops Der GOR-Arbeitsgruppe "OR Im Umweltschutz" am 20./21. Februar 2014 in Heidelberg Und Am 25./26. Februar 2015 in Aachen*. Shaker Verlag GmbH, Aachen, pp. 93–116.
- IV. Savolainen J., Collan, M. and Luukka, P. (2016). Analyzing operational real options in metal mining investments with a system dynamic model. *The Engineering Economist*, DOI: 10.1080/0013791X.2016.1167988.
- V. Savolainen J., Collan, M. and Luukka, P. (2016). Combining system dynamic modeling and the Datar-Mathews method for analyzing metal mine investments. *Acta Universitatis Palackianae Olomucensis. Facultas Rerum Naturalium, Mathematica*. Article in press.
- VI. Collan, M., Savolainen, J., Kyläheiko, K. and Luukka, P. (2016). Examining the effect of capital structure on the flexibility to temporarily shut down metal mining investments: equity holder's point of view, in: Grubbström, H. and Hinterhuber, H. (Eds.), *Preprints, Vol. 2/4, 19th International Working Seminar on Production Economics, Innsbruck, Austria, February 22-26, 2016*, pp. 89–99.

Jyrki Savolainen is the principal author and investigator in papers II, III-V and corresponding author of paper I and IV. He has been the key person responsible for the creation and use of the simulation models applied in the listed papers.

The extended abstract of the paper I was presented by Jyrki Savolainen in a conference "ROW15 – Real Option Workshop, August 18.-19., 2015 in Lappeenranta, Finland" and paper III in conference "Workshop on Sustainability and Decision Making, 25.-26.2.2015, RWTH in Aachen, Germany". For papers II and VI the experiments were jointly designed with the co-authors and Prof. Mikael Collan was the corresponding

author. Jyrki Savolainen modified the available models and conducted the simulations presented in these papers.

---

## List of abbreviations

$C_I(P_d)$	Investment cost as a function of designed production capacity
$C_p(P_d)$	Production unit cost as a function of designed production capacity
$DCF$	Discounted Cash-Flow
$GBM$	Geometric Brownian Motion
$IRR$	Internal Rate of Return
$LSM$	Least Squares Monte Carlo
$max$	Maximum
$min$	Minimum
$NPV$	Net Present Value
$NPV_\mu$	Expected Net Present Value
$MC$	Monte Carlo
$MR$	Mean Reversion
$OM$	Operations Management
$OR$	Operations Research
$P_d$	Production capacity (design value)
$P_a$	Production capacity (actual)
PDE	Partial Differential Equation
Q	Reserve size (ore or metal content)
$r$	Discount rate
$r_{cost}$	Cost discount rate
$r_{rev}$	Revenue discount rate
$R$	Recovery rate of metal
$RO$	Real Option
$ROA$	Real Option Analysis
$ROI$	Return on Investment
$ROV$	Real Option Valuation / Real Option Value
S(t)	Metal price as a function of time

$S'(t)$	Long term equilibrium metal price (in MR-process)
$SD$	System Dynamic
$SDE$	Stochastic Differential Equation
$tot$	Total
WACC	Weighted average cost of capital

*Greek Alphabet*

$\alpha$	Drift term (in GBM-process)
$\eta$	Reversion speed (in MR-process)
$\lambda$	Mean number of events per unit time in a Poisson process
$\rho$	Recovery rate of metal from ore
$\sigma$	Volatility
$\mu$	Mean

# 1 Introduction

## 1.1 Background and motivation

Metal mining investments are practically irreversible, high cost investments with limited lifetimes. This work deals with the economic feasibility analysis of these investments. A techno-economic system dynamic model for metal mining investments is developed in this research. A review shows that this fills a research gap in the research literature on the economic evaluation of metal mining investments and thus makes also the created model a new scientific contribution.

An introduction to general microeconomic features of mining investments is provided by Cairns (1998). The importance of systematic ex-ante (before the fact) analysis is highlighted in the metal mining industry due to some distinct characteristics, which can be listed as:

- Capital intensity
- Long, up to 15 years or longer, lead times from planning to production
- Limited lifetime (due to finite ore reserves)
- Irreversibility: installed equipment is practically mine specific
- Capacity is often fixed at the beginning of deposit exploitation, as expansion may be too costly
- A mining project typically consists of distinct stages from prospecting to reclamation, where the early stages of the process contain high uncertainty and high probability of failure
- Investment profitability is subjected to several uncertainties, such as commodity price uncertainties, orebody-related uncertainties, technological uncertainties, and political uncertainties

For details, see, e.g., Cairns (1998); Frimpong & Whiting (1997); Klossek & Klossek (2014).

A recent study by Crowson (2012) indicates that degrading quality of untapped orebodies has already resulted in a technological shift towards hydrometallurgical methods in mining / enrichment technology and increasing size of new mines. This observed shift emphasizes the importance of ex-ante mine (profitability) analysis.

Metal mining investments are subjected to multiple uncertainties. Some of the key uncertainties include, e.g., the output price of metal(s) (Costa Lima & Suslick, 2006; Tsekrekos, Shackleton, & Wojakowski, 2012; Tufano, 1998) and the geology of the ore deposit (S. A. Abdel Sabour, Dimitrakopoulos, & Kumral, 2008; Azimi, Osanloo, &

Esfahanipour, 2013). These uncertainties can be quantified in the analysis phase. There may be also factors which (usually) cannot be assigned with a numerical value such as political uncertainty regarding the permitting processes of metal mining operations.

In order to distinguish between different types of uncertainties the concepts of parametric, structural, and parametric uncertainties are applied. These are introduced in Dosi & Egidi (1991), Kyläheiko (1998), and Langlois (1984). Kyläheiko (1998) defines parametric uncertainty as a situation, where an agent has knowledge regarding the decision problem and the possible future outcomes, but she has only subjective knowledge of the probabilities of events. Structural uncertainty means that the structure of the future (system) itself is unknown due to, e.g., technological changes (ibid.). The existence of structural uncertainty can void the results from model-based numerical analyses. Dosi & Egidi (1991) attach procedural uncertainty to the inability of the decisions makers to implement decisions on the basis of available information.

The nature of metal mining projects, with distinct project phases and multiple uncertainties, creates flexibility to projects, which we refer to as *real options* (ROs). In a broad sense, a RO is a possibility, but not an obligation to undertake business initiatives that are (typically) connected to real assets. The term “real option” (RO) was most likely used for the first time in the academic setting by Myers in 1977. Myers defined company’s growth options as a source of managerial flexibility, which originates from the company’s available capabilities and competencies, and called this managerial flexibility a real option. The real option framework in metal mining context can be used to enhance or to protect the economic returns from metal mining, when uncertainties unfold, e.g., prices increase/decrease or new information arrives. In general, the highest value from real options is associated with projects or on-going operations that are close to their break-even profitability, i.e., “high cost mines” or “marginal development properties” as defined, e.g., by Roscoe (2002): “properties which contain well-defined mineral resources which would become economically mineable reserves under improved circumstances, and which have enough reliable data to show that the economics are marginal under prevailing conditions at the time of valuation. Improved circumstances can include commodity prices, technological improvements, establishment of local infrastructure, etc.” As discussed above, new metal mining investments are typically related to marginal development properties.

Valuation of real options was originally based on using the models that were created and used for financial option valuation for the valuation of real options. Early financial option valuation models include the Black-Scholes option pricing formula (Black & Scholes, 1973) and the binomial option valuation method (Cox, Ross, & Rubinstein, 1979). Boyle (1977), was the first to apply simulation to the pricing of (financial) options.

The term *real option analysis* (ROA) is often used to refer to thinking about future possibilities in terms of real options in a systematic way. Real option valuation should be understood as the practical application of applying quantitative option valuation methods connected to the identified real options. This study mainly contributes to real option valuation.

For the purposes of this study, two separate simulation models are created. The first simulation model is a system dynamic (SD) techno-economic representation of a (real world) mining investment. The SD-methodology was originally developed by Forrester (1961) and it allows a detailed modeling of complex systems characterized by feedback loops, stocks, and delays. The second model is a simpler, static simulation model that is usable in (rapidly) simulating millions of possible outcomes, based on a limited amount of quantitative information.

There have been two main objectives for this research: the first main objective has been to create a realistic, techno-economic feasibility analysis model of metal mining investments could the aim of which is properly take into account the special characteristics of metal mining investments, while preserving relatively simple mechanics of analysis. To the best of our knowledge, a system dynamic model specifically built for metal mining investment profitability analysis has not been previously presented in the scientific literature. The second main objective has been to apply the constructed SD-model to the analysis of real options in metal mining investments.

The scientific contributions of this research include the development of the first techno-economic system dynamic metal mining investment analysis model, presenting new and interesting results with regards to the value generated by real options to metal mining investments, and new results with regards to how financing may affect the value of real options in metal mining investments and consequently the investment value to equity holders.

This work should be of benefit to the mining industry and to the various interest groups linked to the investment decision making of metal mining investments, e.g., to creditors, financial analysts, legislators, and to policy makers.

## 1.2 The focus of this research

The focus of this research is on the study of *real option valuation of metal mining investments* and we assume that the uncertainty that we are facing is of the *parametric uncertainty type* that allows the use of system dynamic modeling. Figure 1 presents visually how this research on real options is focused with regards to the underlying themes of system dynamic modeling, metal mining investments, and feasibility analysis (of metal mining investments).

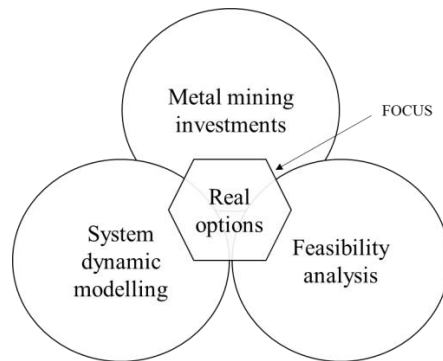

**Figure 1.** The focus of this research

This research positions itself in the context of management accounting of metal mining companies – and more specifically in the context of the capital budgeting process. Management accounting can be defined as (IMA, 2008): “- a profession that involves partnering in management decision making, devising planning and performance management systems, and providing expertise in financial reporting and control to assist management in the formulation and implementation of an organization’s strategy.” Organizational capital budgeting process can be divided into four distinct phases according to Mukherjee & Henderson (1987): identification of opportunities; development of investment ideas; selection of a project; control and post-audit. This work concentrates on the “development of investment ideas” and on the “selection of a project” parts of this taxonomy.

There are two reasons to make metal mining project valuations according to (Laughton, 2007): firstly, for purposes of *trading of assets in the markets* and, secondly, for *decision making*. As the focus of this study is on the decision making aspects in a capital budgeting process, the resulting numerical values derived here should not be taken as generally accepted truths, but more as a tool for comparing different decision making alternatives.



**Table 1.** Valuation methods as presented in CIMVAL (2003) and the focus of this thesis. (\*) = *The method is not normally used in valuation.*

Approach	Method	Focus
<i>Income</i>	DCF	x
	Monte Carlo	x
	Option pricing	x
	Probabilistic (*)	-
<i>Market</i>	Option agreement	x
	Comparable transactions	-
	Net metal value per unit (*)	-
	Value per unit area (*)	-
	Market capitalization (*)	-
	Gross "in situ" metal (*)	-
<i>Cost</i>	Appraised value	-
	Multiple of expenditure	-
	Geoscience factor (*)	-

In the industry, there are several widely accepted methods to estimate the value of a mining asset. The methods can be divided into cost, income, and market based approaches (see, (CIMVAL, 2003; SAMVAL, 2009)). In this thesis, the focus is on applying the most commonly used income and market based valuation methods (table 1). For a detailed review of valuation methods, we ask the interested reader to see (Eves, 2013).

### 1.3 Objectives of this research and connected questions

As discussed above, the main objectives of this research were to create a techno-economic system dynamic model of a metal mining investment and to use it in studying the real options of metal mining investments. In this vein the SD-model is built such that it can:

- Take into account multiple and interdependent uncertainties, which can be both statistical representations and/or subjective expert estimates
- Respond to uncertainty realizations with multiple managerial flexibilities, such as temporary closure, expanded production, and aid in production planning
- Integrate different technological and economic aspects of metal mining investments ranging from production to financing

Specific research questions that this research strives to answer are:

Does a system dynamic modeling fit metal mining investments and if so, then what possible benefits arise from using SD-model to real option valuation compared to existing models?

Does the capital structure have an effect on the value of real options in metal mining investments?

Does the selection of the metal price process used in profitability analysis of metal mining investments have an effect on the investment value and on the value of the real options in metal mining investments? If yes, what is this effect like?

These three research questions are important issues connected to metal mining investments and answers to the questions should be of interest and be important to the mining industry as well as interesting to the academic community.

## 1.4 Outline of the thesis

This thesis is based on a collection of articles with the common theme of modeling and profitability (real option) analysis of metal mining investments. The models developed in this thesis use established techniques of mathematics and computer science. It is claimed that they can be used as a tool for improving a systematic and rational investment decision making processes under parametric uncertainty, when the decisions are made on the basis of investment value maximization and/or risk minimization.

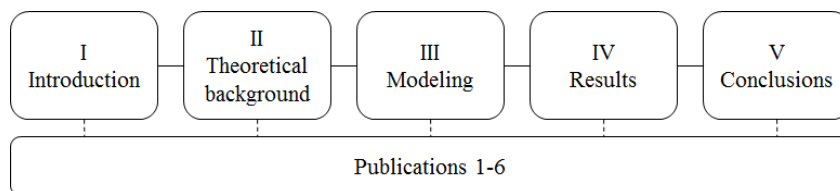

**Figure 2.** The outline of this thesis.

The thesis consists of five chapters in the introduction and the publications (see Figure 2). Chapter two gives an introduction to theoretical background and presents the relationship between the academic literature identifying the research gap that this research sets out to fill. Chapter three is a description of methods. Chapter four presents the two created models and compares their characteristics to the existing modeling efforts found in the literature. Chapter five is devoted to conclusions and discusses the contributions of this research; also questions of model validity and relevance are addressed. Lastly, some directions for future research are proposed.

## 2 Theoretical background

### 2.1 Methodology framework

This research is based on a “systems point of view for science” as presented by Mitroff, Betz, Pondy, & Sagasti (1974). They suggest that in the context of operations management science there is no definite “starting” or “ending” points for scientific inquiry, as illustrated in the schematic diagram in Figure 3.

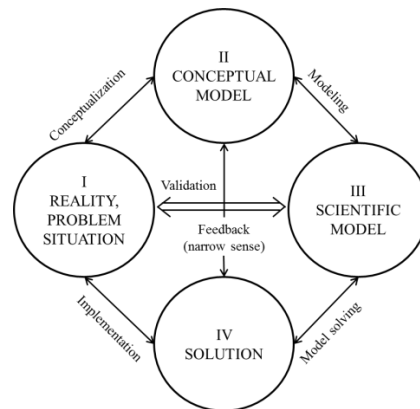

**Figure 3.** Systems view of problem solving according to Mitroff, Betz, Pondy, & Sagasti (1974).

Using the framework illustrated in Figure 3, the methodological path of this work can be traced. The origins of this thesis lie in the observed reality (point I) of having inadequate capabilities to model and analyze the value of real options in the context of mining investments. The problem is conceptualized by investigating the real world of mining investments (point II) and a scientific model is created (point III) in the form of the simulation models created.

The model (“artefact”) is solved (point IV) by simulating through the created models and different variations of this model solving are presented in the presented papers. That is: “– the solution is ‘fed back’ to the problem for the purpose of taking action on it – “ (Mitroff et al., 1974). The procedure is iterated multiple times. As Bertrand & Fransoo (2002) note this type of approach has only narrow feedback in relation to reality and one should not mistake the model solving process taken here to actual implementation of the model (arrow from I to IV). Therefore, they continue, a scientific claim concerning reality cannot be put forward on the basis of indications of narrow feedback.

As it has been discussed above, here a system dynamic (SD) methodology is applied in model building. With regards to this methodology, Größler et al. (2008) distinguish two types of theories: structural theories and content theories. Größler et al. (2008) classify system dynamics -method as a structural theory of dynamic systems, which are characterized by feedback loops, accumulation and delays. A specific SD-model of a real world system, such as the one introduced in this thesis, is a specific content theory of the setting representing real-world objects and linkages between them as they are hypothesized to exist (ibid.).

## 2.2 Philosophical position of the research

Hopper & Powell (1985) identify four mutually exclusive schools of accounting research: functionalist, interpretive, radical humanist, and radical structuralist. This work represents the functionalist paradigm, which includes several assumptions (Hopper & Powell, 1985): organizations have unitary goals (i.e., profit maximization), human nature is assumed calculative and rational striving. In other words, a *rational decision maker assumption* is used. The decisions are assumed to be based on a systematic profitability analysis of a particular investment. However, a review of organizational practices conducted by Mukherjee & Henderson (1987) indicate that the selection criteria of value maximization is often compromised in real life. They show that investment decision making process includes a variety of agency, power, and political issues inside an organization and unbiased data for decision making may not be available, or it is too costly. Further discussion about these “agency issues” is omitted in this study and it is assumed that the development (to a positive, more realistic direction) of quantitative investment analysis tools and processes creates a positive effect on the decision making ability of an organization.

In the investment literature another area of philosophical discussion is the separability of investment decisions and financial planning (see, e.g., Esty, 1999; Herrero de Egaña, Soria Bravo, & Muñoz Cabanes, 2016; Singhvi & Lambrix, 1984). Modigliani & Miller (1958) stated that “the average cost of capital to any firm is completely independent of its capital structure and is equal to the capitalization rate of a pure equity stream of its class”. This suggests that from the capital cost point of view the capital structure is irrelevant and no optimal capital structure exists. However, Modigliani & Miller (1958) themselves point out that their analysis is static and as such ignores aspects such as possible variability of expected rate of return over time for different assets and market imperfections, such as the availability of funding. In the research we assume unideal market conditions to hold in the context of metal mining industry and therefore investment decisions may be coupled with the aspects of financing.

Mitroff (1969) suggests that any discussion regarding the simulation of reality must eventually define the philosophical foundations of reality, which it is based on. In this

---

work the philosophical position in relation to theory is based a view discussed in (Weber, 2003) that *things* and *properties* of things exist: the properties of things are its *state* and the changes of states that occur to a thing are *events*.

The studied *phenomena* that are sought to account are the states or events. *Laws* specify the values of states of a single thing or the relationship between the states of different things. *Construct* is a property or a composite thing. (Weber, 2003)

Barlas & Carpenter (1990) present a historical review on philosophy of knowledge with respect to system dynamics methodology. They note that mainstream theories of knowledge assume it to be an “entirely objective, asocial, acultural, and ahistorical ‘Truth’ rather than a socially justified belief” requiring utopian objectivity and formalism to any scientific inquiry. In this thesis we take a relativist position in relation to knowledge. Reality is not an isolated object, but model building and validation are relative to the modeler’s theory of scientific inquiry (Barlas & Carpenter, 1990; Mitroff, 1969). The constructed models are built to reflect the best of the understanding of the modelers.

According to Barlas & Carpenter (1990) and Barlas (1996), there is no formal or objective theory of confirmation, but the validity of a model depends on the philosophical assumptions of what reality is. Mitroff (1969) writes that the investigator of a model accepts a verification that represents her view of the reality. Therefore, he concludes, as beliefs or in other words “reality” change, no final verification may be achieved, as it determines what kind of behavior is desirable in order to validate a simulation. A model is only one of many ways to describe a real situation and the model should be evaluated on the basis of its usefulness respect to its purpose (Barlas & Carpenter, 1990).

### 2.2.1 On uncertainty and probability

Lawson (1988) suggests a classification of uncertainty into two types: first, realist point of view, where probabilities are a property of external material reality, i.e., objects of knowledge. Secondly, a subjectivist point of view in which probabilities are something which an agent possesses or attaches to given propositions at some specific point of time - that is, the probability is viewed as “a form or an aspect of knowledge”. Lawson (1988) continues that in the latter case probabilities regarding any proposition or event cannot be proven right or wrong, as the (subjective) knowledge can be unrelated to external reality. Table 2 is an illustration of different aspects on uncertainty.

**Table 2.** Schematic classification of prominent accounts of probability and uncertainty in economic analysis (modified from Lawson (1988)).

	<b>Probability is a property of knowledge or belief</b>	<b>Probability is also an object of knowledge as a property of external material reality</b>
<b>Uncertainty corresponds to a situation of numerically measurable probability</b>	Subjectivists: agents attach probabilities. Exclusive "states of the world"	Proponents of rational expectations view: parameters of probability distributions are known, which characterize uncertainty
<b>Uncertainty corresponds to a situation of numerically immeasurable probability</b>	Keynesian uncertainty: absence of probabilistic knowledge	Knight's uncertainty: no measurable probability is possible, but "probability judgements" can be given

In this research a “midway” approach to objective-subjective probability discussion is adopted. Objective in a sense that it is believed that historical data analysis can provide insights into the future prospects of certain market variables such as foreign exchange rates and inflation. Lawson (1988) uses term “interactionist realism”, which “allows for agent knowledge to come to grips with external reality”. That is, he continues, the appearances of objects are related to reality, but thought, reason and interpretation are essential in the process of gaining knowledge of the reality. An example of converging probability distributions could be the drilling data results from an orebody: it is certain, that there exists an objective metal grade distribution of any finite (part) of an orebody. However, in very early stages of a project only subjective estimates can be used, because of the lack of data. As the amount of data increases, the initial (subjective) estimates are gradually updated to better match the objective metal grade probability distribution

On the other hand, in this research possibility to sudden changes in distribution functions are not considered impossible and subjective distribution functions are liable to exogenous changes, meaning that they do not necessarily have to approach objective functions. For instance, the use subjective expert estimates on price turnarounds is “allowed”, which do not necessarily match the historical statistics in a given forecast period. As Lawson (1988) summarizes, knowledge may involve real indeterminateness, it is fallible and can be replaced by fuller truths.

### 2.2.2 On simulation models in quantitative operations management research

Term ‘model’ in a broad sense can be defined as (Emshoff, 1978): “... a simplified representation of reality that can be manipulated to forecast the effect of taking specific actions”. A review to business process modeling techniques is provided by Giaglis (2001), who writes that the simulation is an indirect method of study, in which an entity, “sufficiently similar to the real world system”, is created and studied. On the basis of

---

similarity condition, one can be confident that some of the lessons learned about the model will also hold for the true system (ibid.).

Barlas (1996) classifies models into two different categories: “white box” and “black box”. Latter type of models have no claim of causality and their validity should be evaluated on the basis of results attained in analyzing a real data feed. The formal accuracy is more important than the practical use of the model (Barlas & Carpenter, 1990). The white box models, on the other hand, they describes as “causal-descriptive” explaining how real systems operate in some aspects. Causal relationships are presented between control- and performance variables, where the latter can be either physical or economic (see Bertrand & Fransoo, 2002). The models presented in this thesis are white box models.

According to Bertrand & Fransoo (2002): “Quantitative models are based on a set of variables that vary over a specific domain, while quantitative and causal relationships have been defined between these variables”. They continue that, because of causal relationships, future states of the processes can be predicted and the models are not restricted to explaining actual observations. In other words, research is based on rational knowledge generation assuming that objective models can be built which explain (part of) the real life operational processes and decision-problems (Bertrand & Fransoo, 2002).

### **2.3 State of the art of profitability analysis in metal mining**

Practically any metal mining project, either at the planning desk or in operation, has to have a long-term feasibility calculation. The proof of feasibility is typically demanded at the least by the (potential) investors and creditors. Several industry codes and guidelines (e.g., IMVAL, 2015; JORC, 2012; NI 43-101, 2011; SAMVAL, 2009; The VALMIN Committee, 2015) exist regarding the valuation methods of an undeveloped or developed ore deposits.

Although the industry codes acknowledge the existence and appropriateness of alternative feasibility analysis methods, the traditional discounted cash-flow (DCF) –based methods have retained their position as an industry standard against which the results of alternative methods are often compared. As Humphreys (1996) notes, the alternative analyses are practically irrelevant from the company decision-making point of view, if a project cannot survive a simple DCF analysis in the first place. Also Martinez and McKibben (2010); Moyen et al. (1996); Slade (2001) suggest that DCF-based methods are likely to remain a dominant valuation tool for mines with what they call “healthy” cash-flows.

In a general form, DCF and the closely related concept of net present value (NPV) can be written as a function of project cash-flows (revenues minus operating costs) and the initial investment:

$$DCF = \sum_{i=0}^n \frac{CF_i}{(1+r)^i} \quad (1)$$

$$NPV = \sum_{i=0}^n \frac{CF_i}{(1+r)^i} - I_0 \quad (2)$$

where  $CF_i$  is the cash-flow (revenues less costs) for year  $i$ ,  $I_0$  is the initial investment and  $r$  is the discount rate representing the risk. Appropriate discount rate can be estimated on the basis of similar (type of) investments. Often a company-specific weighted average cost of capital (WACC) is used as the discount rate, but a correct risk-corrected discount rate specific for project cash-flows should be used. A survey of metal mining companies by Bhappu & Guzman (1995) show that political risk, commodity risk, and technology risk are the primary drivers for adjusting the project specific discount rate. If the discounted cumulative cash-flow from an investment is positive, i.e., if  $NPV > 0$ , then by investing in the asset one is expecting to make a wealth creating investment.

The DCF-calculation assumes that the yield of the investment is periodically paid to the investor as if she owned a portfolio of risk-free bonds. In the context of metal mining investments, this may not be the case, as the output prices of metals can vary tens of percent per year (see discussion, e.g., Brennan & Schwartz 1985a). Therefore, excluding the possibility of hedging, the investment return can vary from grossly negative to positive, in the course of time.

In a case of complex investments, such as metals mining investments, the DCF-calculation is typically divided into small components and by doing so the level of detail and complexity of the analysis is increases (Figure 4).

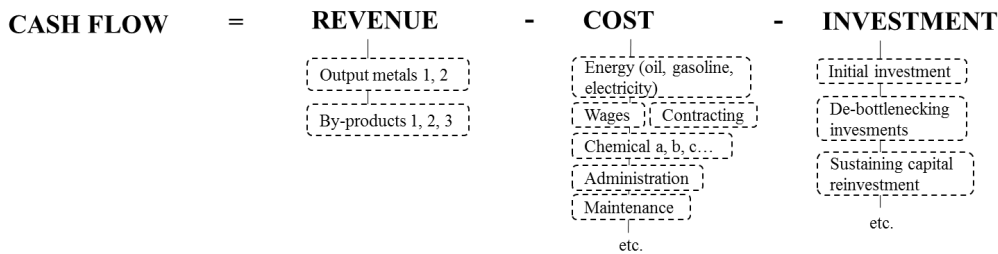

**Figure 4.** An illustration of typical cash-flow components of a metal mining investment analysis

To deal with the complexity of the metal mining investment DCF-calculation, the analysis is usually done with spreadsheet software. The spreadsheet-based feasibility calculation or “cash-flow model” is a standard tool inside the mining companies for capital budgeting purposes. In a typical case it also serves as a tool for communication to outside the organization, when raising funds, in the form of equity or loan.

Despite its wide acceptance, the DCF-method has some serious drawbacks. Several authors (e.g., Davis, 1996; Esty, 1999; McCallum, 1987; Samis, Martinez, Davis & Whyte, 2012; Smith & McCardle, 1999) have raised a concern that the risk-adjusted



---

discount rate may undervalue projects with long time horizons (of 30 to 40 years) and favor quick payoffs. Cavender (1998) and Davis (1996) report that the historical prices of exploration assets seem to have been higher, than a static DCF-analysis indicates. This suggests the existence of an option premium in the markets on these projects. This gap in pricing may be explained by the DCF-method's inability to properly account for the future uncertainty, which is also the source of real option value. In DCF-calculations the uncertainty is only reflected via the applied discount rate, which makes the method vulnerable to errors.

To deal with the price uncertainty related to an operating mine Brennan & Schwartz (1985a, 1985b) suggested that a mine should be valued, analogically to stock option, as an option to obtain uncertain cash-flows. The realization of cash-flows are contingent on the development of metal price(s). The research of Brennan & Schwartz is widely recognized as pioneering in the real option valuation of mining assets (see discussion in Azimi et al. 2013; Coldwell et al. 2003; Cortazar et al. 2008; Haque et al. 2014). Brennan & Schwartz (1985a, 1985b) had an idea of a risk-free valuation approach that could be achieved by hedging production with commodities futures that replicate the asset that is being valued. The idea is that the exercise price of the real option on a mining project equals the extraction costs of metal and the possible development cost. As Smith and Nau (1995) summarize, a project can be regarded unattractive, if the same returns could be obtained cheaper by using publicly traded market derivatives.

It has been suggested that publicly available future and forward prices of metals may also be used as certainty-equivalents in the valuation-process of metal mining projects. However, the maturities of these contracts are typically of only a maximum of two to five years, as highlighted in Guj and Garzon (2007); McDonald and Siegel (1985); Schwartz (1998); Smith and McCardle (1999); Triantis (2005) making using them only a partial solution at best.

Although the theoretical foundations of Brennan & Schwartz (1985a, 1985b) were laid three decades ago, there is still relatively scarce literature on the practical applications of their work and on real option analysis on metal mining investments in general. Smith and McCardle (1999) and Trigeorgis (1993a) criticize bringing the financial option analogy to real assets as an oversimplification, their point being that most real options are typically series of (real) options. Miller and Park (2002) furthermore note that the exercise price of a real option may "occur" in terms of several payments over time, without actually having a single specific time for exercise. According to Smith and Nau (1995) most real projects cannot be hedged perfectly by market securities, as such securities may not be available and as there is always technical uncertainty about the mine being constructed (inability to actually estimate the "size of the risk being hedged").

The inability to adequately present the complexity of mining investments and the rather sophisticated mathematics behind the Brennan & Schwartz (1985a, 1985b) model have reduced its usability to the mining industry practitioners, as was discussed in Cortazar and Casassus (1998); Haque et al. (2014). This is also true in the wider perspective of real option valuation, as noted by Lander & Pinches (1998) and Ryan & Ryan (2002). Laughton (2007) even calls the financial option analogy as a methodological dead end.

Surveys of Bartrop & White (1995); Bhappu & Guzman (1995); Moyen et al. (1996); Slade (2001); Smith (2002) indicate that mining organizations typically (and only) seem to utilize static discounted cash-flow (DCF) methods such as the NPV and the Internal Rate of Return (IRR) in their investment decision-making.

Evidently, both the DCF- and the financial option analogy have their drawbacks: DCF for not properly taking into account the uncertainty of markets and managerial flexibility, and financial option analogy for neglecting the unique characteristics of individual projects. In summary, there is a gap between complexity of metal mining investments and the capabilities of modeling as typically used in the industry today (per 2016 AD).

The first research question of this thesis concerns the applicability of system dynamic - method to metal mining investment modeling. The main reason here for why the SD-method is applied is to achieve what is called “requisite variety”, see Ashby (1958). Järvinen (2000) summarizes what requisite variety is as follows: “– the variety of regulator plus the regulatory effects of outer arrangements must be greater than the variety of disturbance and the variety of regulator’s uncertainty.”

The idea of requisite variety can be extended to the properties of different types of models and systems. Put simply requisite variety means that a system that is built to present a phenomenon should be as complex as the phenomenon itself.

In the context of a cash-flow model of an operating mine, one should, e.g., input data from various disciplines such as geology (e.g., metal contents of ore, tonnage), financial administration (e.g., price assumptions, exchange rates), management (e.g., operational strategies) to reach a realistic level of complexity. The role of an information system, according to Wand & Wang (1996), is to provide a representation of a real world system as perceived by the user.

In vein with the above, the objective this research is to create a model that will be closer to reality, than previous real option analysis models constructed for metal mining investments. The simple spreadsheet-based models commonly used in the industry may be inadequate in representing the real-world complexity of a real metal mining investment.

## 2.4 Real options in the metal mining industry

The value of a metal mining project is neither determined in the initial analysis, nor purely as a function of the commodity (metal) markets. Value is dependent on the (right) timing of the investment and the unfolding uncertainties (and reactions to them) during the operation period. These issues can be dealt with the theoretical framework of real options.

For the purposes of this work, real options of metal mining industry are classified as real options *on* and *within* projects. Similar type of general classification for real options has been proposed by, e.g., Botín et al. (2012). The real options *on* projects (table 3) refer to strategic type investment flexibility. Ability to delay decisions, or to abandon the project,

can add value compared to making the building decision at the start of the project. Adner & Levinthal (2004) and Herath & Park (2002) discuss these types of multi-stage capital investments, in which earlier investments provide a right to sequential options depending on uncertainty realization. Metal mining operations are established in stages and may be stopped in case of unfavorable outcome at any stage of the project.

ROs *in* project (table 3) are used in the meaning of production system based flexibilities on the operation level such as temporary closure, expansion, or mine planning. Real options *in projects* represent available managerial flexibilities from “an industrial engineering/production management perspective” (Bengtsson, 2001). Groeneveld and Topal (2011) suggest that real options “in projects” can be understood as flexibility of the underlying engineering system to respond to the resolution of uncertainties. de Neufville (2003) extends the concept of real options to cover all the flexibility providing elements of an engineering system.

**Table 3.** Possible real options *on* and *in* a metal mining project

Real options <i>on</i> project	Real options <i>in</i> project
Exploration (learn)	Flexible production design
Development (plan)	Defer investment
Extraction (build)	Stage investment
Abandon	Pit design and phasing (Cut-off)
	Block sequencing (Cut-off)
	Cut-off grade
	Stockpiling
	Expand production
	Contract (scale down) production
	Temporary closing
	Switch output

Uncertainty is the inherent source of real option value. A mining project is subject to multiple uncertainties originating either from the markets (external uncertainties), or from the project itself (internal uncertainties). Driouchi & Bennett (2012) refer to these as *exogenous* and *endogenous uncertainties*. Ross (2004) suggests that the endogenous uncertainties are not subject to volatility and that it may be reduced by active learning. Exogenous uncertainties, on the other hand, vary in an unpredictable manner and their future values cannot be resolved until the “future arrives”.

The orebody uncertainty is fundamentally different compared to parametric uncertainty of economic variables. As Dowd (1994) writes, the ore grade and tonnage are functions of locations in the orebody with limited access at a given point of time. The type of uncertainty is endogenous in a sense that it is cannot be resolved by waiting, but only through investment and learning. A discussion regarding different uncertainties of metal

mining projects can be found, e.g., in Bhappu and Guzman (1995); Botin et al. (2013); Dehghani and Ataee-pour (2012); Dimitrakopoulos et al. (2002); Kenzap and Kazakidis (2013); Lawrence and Dewar (1999); Mayer and Kazakidis (2007); Park and Nelson (2013).

In a metal mining project it is common that more than one real option is available to deal with the prevailing uncertainties at any point of time. To increase the complexity of the situation at hand even more, different real options may have mutual interactions and many of them have a path dependent nature. Trigeorgis (1993b) shows that real options are usually non-additive, when they exist on the same real asset. Furthermore, the value of real options changes as a function of multiple uncertainties, making it often hard or impossible to calculate the precise value of these options, without oversimplifying the reality of metal mining. As Laughton (2007) notes, there is a trade-off between reality of real option analysis and computational complexity; lower complexity is better for computational and for “presentational” reasons.

There are several methods for deriving numerical solutions to real option problems. According to Bjerksund and Ekern (1990) the choice of appropriate solution method is a trade-off between insights of analytical solutions and the realism of numerical solutions. Collan, Haahtela & Kyläheiko (2016) suggest that the selected real option solution method should correspond to the prevailing uncertainty type of the decision problem. This suggests that the financial option valuation methods, such as partial differential equations (PDEs) and binomial trees may not be the best choice of method in the context of metal mining investments. Suitable real option analysis methods for investment analysis under parametric uncertainty include simulation based models (Datar & Mathews, 2004; Mathews & Datar, 2007; Mathews & Salmon, 2007) and methods that use fuzzy logic to model the imprecise information available (Collan, Fullér, & Mezei, 2009; Kuchta, 2000). System dynamic simulation models seem to be considered to be suitable for the numerical real option analysis / valuation of metal mining investments. The benefits of simulation include easy applicability for multi-factor models and path dependent problems, as discussed in Abdel Sabour and Poulin (2006); Dimitrakopoulos and Abdel Sabour (2007); Lin and Wang (2012); Longstaff and Schwartz (2001); Samis et al. (2012); Schwartz (2013); Triantis (2005). However, simulation methods are unable to arrive at analytical solutions for real option problems. That is, the mathematical elegance and generalizability of solutions is lost. It is for this reason, a relativist view of the philosophy of knowledge has to be adopted.

Abdel Sabour & Dimitrakopoulos (2011); Newman, Rubio, Caro, Weintraub, & Eurek (2010) suggest that the research in mine planning is evolving towards solving increasingly complicated, non-linear stochastic models with the help of modern-day simulation software tools. This thesis continues from this observation on this very line of research by introducing the first system dynamic model for real option valuation of metal mining investments. The SD-model is introduced in detail in chapter 3.

## 2.5 System dynamics

In this research the methodology of system dynamics is the tool of choice. This is done to meet the demands of requisite variety in modeling of metal mining investments. System dynamics is a set of tools, which relates “the structure of complex managerial systems to their performance over time, via the use of simulation” (Giaglis, 2001). The applicability of SD-models in operations management (OM) research is discussed in Größler, Thun, & Milling (2008).

According to Barlas (1996) there are two main reasons to create system dynamic models: first, “modeling/analysis of a real system in order to improve some undesirable performance patterns” and secondly, “modeling of an existing theory in order to evaluate/test the theory”. The key benefits of system dynamic models include (Forrester, 1994): accepting complexity, nonlinearity and feedback loop structures, which are inherent in real world systems. In other words, system dynamic models acknowledge the cumulating history of the systems, which influences their future (Größler et al., 2008). Größler et al. (2008) concludes that these distinct features of SD-modeling may give new and additional insights into existing OM-problems.

The nature of system dynamics with feedback loops, accumulation and delays usually lead to a non-linear behavior of the overall system. Therefore, the system dynamic models should be seen as descriptive rather than as normative representations of a real world systems. That is, the main purpose is to propose the implementation of improvement and not to aim for an optimal system state, which may only be attained in low-complexity, artificial situations, or in situations with no uncertainty involved (see discussion Größler et al., 2008).

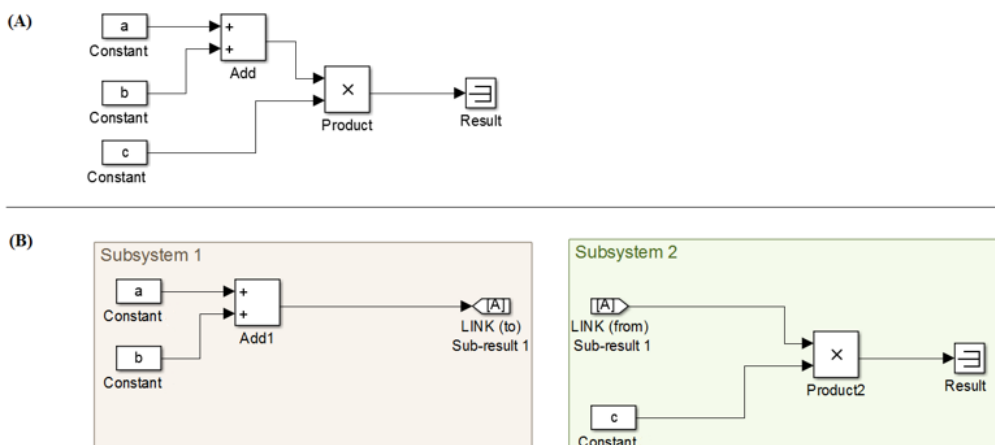

**Figure 5.** Illustrative example of a function block diagram. (A): Example system; (B): Example system divided into two subsystem.

The benefit of SD-models is that they are modular, and therefore the individual parts of the system can be modified without having to alter the system as a whole. Presentation of any SD-model is given as a function block diagram instead of a collection of analytical equations. This allows intuitive modifications to different parts of the model. If needed, however, the underlying equations can be derived on the basis of function block diagrams. To illustrate this, a simple function block diagram is shown in Figure 5.

The function block diagram in Figure 5 is read from left to right. Looking at Figure 5a with three constant inputs  $a$ ,  $b$ , and  $c$ . One can see that the “Add” function block equals to “ $(a+b)$ ”. The output of “Add”-function is fed to input for the “Product”-function with constant value “ $c$ ”. Therefore the result of product function would be analytically written as “ $(a+b)*c$ ”. The logic applies throughout all the subsystems of the SD-model.

Simon (1962) discusses the benefits of dividing a complex system into subsystems (or subassemblies). He suggests that using stable subsystems, or stable intermediate forms as elementary building blocks, reduces the time of completion and increases the odds of creating a stable complex system. Figure 5b illustrates how a system is divided into two subsystems performing an identical function compared to the original system configuration. Note that the subsystem 1 functions independently of subsystem 2.

Because of the modular and hierarchical structure, the SD-model is able to evolve and adapt to new organizational requirements continuously. Truex, Baskerville, & Klein (1999) claim that rigid information systems with long life spans rather inhibit than facilitate organizational change, as the system cannot match the organizational change, and therefore a complete specification for a stable system does not exist.

According to Hopper & Powell (1985) the system based approach assumes that the key relationship between an organization and its environment is the organization’s need for survival. If one subsystem fails in its duties, the organization’s survival is compromised. Simon (1962) uses a classification of nearly decomposable systems, in which the interactions between subsystems “are weak, but not negligible”, when only a fraction of all possible interactions needs to be modeled. He suggests that in general high frequency dynamics are within single subsystems and low frequency dynamics between multiple subsystems. According to Simon (1962), the short term behavior of each subsystem is approximately independent in relation to other components, but the long term behavior of any component depend only on the combined behavior of the other components. The behavior of a complex system can be simplified, when having a hierarchic structure in a complex system and a property of near decomposability (Simon, 1962).

## 2.6 Monte Carlo simulation

According to (Mitroff, 1969) the idea of a simulation model is to represent reality – not to imitate it. Simulation technique is especially usable in situations, where the testing of the real system is hard or even impossible. That is the case also with metal mining investments - although a practically unlimited amount of possible futures exists for a unique investment under study, only one of the possible futures will materialize. Wallace (1998) highlights that the simulation technique itself does not produce solutions that would indicate if a solution is good or bad in general (absolute terms), but it is only a tool to evaluate the set of possible solutions, e.g., “solution *a* is better than *b*”.

Monte Carlo (MC) method in a broad sense refers to random sampling used to obtain a distribution of numerical solutions to a problem. Wallace (1998) writes that random sampling is usually applied, when the universe of possible solutions is too large to be solved completely. He continues that the method is used in the hopes of producing “a representative set of possible optimal solutions” and the optimal solution *may* lie within the candidate solutions. In this research, randomly drawn variables are fed in to the models to create random, but possible, outcomes of profitability. In a case of multiple uncertainties, the random sampling of numbers may result in unrealistic combinations of values and consequently also in unfeasible model outcomes. This issue can be partly dealt with by using multivariate random distributions, or by otherwise creating dependencies between different variables.

As the analytical solution is not reached using the Monte Carlo method, the range of possible solutions obtained from the MC-method may be considered only as the best set of known solutions. That is, the optimal solution may not be within the set of simulated solutions. Another issue is the time consumed by repeated runs of the models. With modern day computers and advanced software, however, this problematic issue has been largely overcome.

## 2.7 Probability distributions and stochastic differential equations in representing uncertainty

In order to calculate real option values of projects with simulation, some forms of numerical representation of uncertainty has to be used. In this research two methods are applied: probability distributions and stochastic differential equations (SDEs).

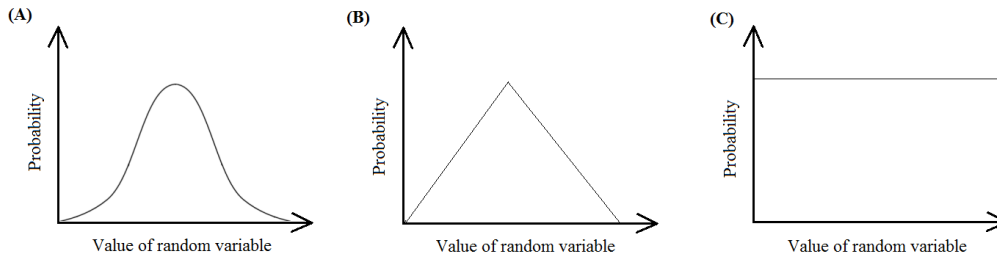

**Figure 6.** Different probability distributions: (a) normal; (b) triangular and (c) uniform probability distributions.

Probability distributions are used in the generation of pseudo-random numbers (inputs) in the simulation procedure, as they are the specified ranges of possible values from within which the simulation randomly draws the pseudo-random numbers. The distributions may be created on the basis of available knowledge (e.g., metal grade distribution) or the distributions may be based on subjective expert estimates, which set the possibility range of uncertainty realization. When there is only limited knowledge available, as is the usual situation in investment decision making, normal, uniform, and triangular distributions are often applied (see Figure 6).

The creation and use of probability distributions may lead to a question of being able to choose the correct, most realistically fitting type of distribution. Critics claim that an analysis done with an “incorrect” type of probability distribution is worth nothing. Wallace (1998) responds to this critique by pointing out that, if no kind of probability distribution is used, then all the “probability mass” is put in one point. He concludes that the opponents’ proposed solution is very inconsistent with the original argument.

Stochastic processes can be defined as: “families of random variables depending upon a parameter” (Davidson, 1982). Therefore, SDEs are path dependent in nature, and thus generally applicable to modeling of financial variables that are subjected to volatility. SDE-variables may include, e.g., metal prices, inflation, exchange rates, and interest rates. In the simplest case, metal prices are assumed to follow a random walk process (e.g., geometric Brownian motion, gBm). Its logarithmic returns are normally distributed outcome over any finite time interval. The formula for gBm can be written as (see e.g., Dias (2006)):

$$dS = \alpha S dt + \sigma S dz \quad (5)$$

where  $\alpha$  is the drift,  $\sigma$  is the volatility and  $dz$  is the Wiener increment.

According to (Davidson, 1982) a stochastic process is stationary in a strict sense, if all its random variables are defined for all points of time and it is independent of time. From the stationarity assumption follows that the process is independent of historical time and an economic decision maker can maximize his returns based on the mathematical expectation (expected outcome) (Davidson, 1982).



---

Davidson (1982, 1991) uses a definition of ergodic stochastic processes for SDE's whose averages of past observations (time average) cannot persistently differ from the average of all possible future outcomes (i.e., statistical average). Thus, calculating the time average over a finite time interval can provide an estimate of the underlying statistical average, but stochastic properties also limit the potential upside and downside of an investment (Davidson, 1982). The principle of ergodic stochastic processes is "violated" in certain parts of this research as subjective price expectations are used together with stochastic processes in deriving what is called "cycle reverting" (CR) stochastic differential equations.

### 2.7.1 Stochastic differential equation models for metal markets and expert judgment

The often used gBm-type representation may be adequate representation of uncertainty, when dealing with large number of publicly traded assets and when the law of large numbers holds. However, market dynamics of commodities and individual metals suffer from non-ideal supply-demand conditions. The excess co-movement of commodity prices was first proven by Pindyck & Rotemberg (1990).

The non-ideal nature of commodity markets leads to sudden price increases due to inadequate supply and consequently long recessions of prices, because of occasional production surpluses. Auger & Guzmán (2010) note that although the technique for modeling of price cycles is yet unclear, their existence in mineral markets should not be omitted, as they are observed to correlate to some extent with macroeconomic cycles.

There are several different models for explaining the generation of price cycles. Theory of metal price cycles can be built on the long-term supply and demand conditions. Pindyck (1999) writes that it would be ideal to explain prices on the basis of supply and demand and their underlying variables. The difficulty is how to define these structural parameters in a long-term models (ibid.). For example, the storage levels of commodities can have a significant effect on the convenience yield of commodities and therefore their price evolution (see, e.g., Amram & Kulatilaka, 1999; Casassus & Collin-Dufresne, 2005; Gibson & Schwartz, 1990). Watkins & McAleer (2004) note that metal markets are largely affected by structural changes and by market speculation. Historical data of metal prices is analyzed, e.g., in Chen (2010); Labys, Achouch, & Terraza (1999); Roberts (2009) and Rossen (2015).

Bernanke (1983) explains cyclical fluctuations of markets with periodically reviewed probability distributions, which agents use to make investment decisions. He suggests that the current existing probability distribution is replaced at random intervals by a new one. In the metal mining context, Humphreys (2010) discusses how the price expectations were renewed during the latest metals boom.

To deal with the above discussed issues present with metal prices, several additions and modifications to gBm-modeling have been proposed. A detailed introduction to commodity markets (and processes used to model them) is provided by Geman (2005). In practical oriented literature a typical solution is to use mean reverting (MR) equations for uncertainty modeling. Mean reversion is based on an assumption that market prices revert towards the average costs of production in the long term, although high prices may occur due to short-term inadequacy in supply. The MR-equation can be formulated as (De Magalhaes Ozorio, Shevchenko, & De Lamare Bastian-Pinto, 2013; Guimaraes Dias & Carlos Rocha, 1999; J. E. Smith & McCardle, 1999):

$$dS = \eta(S' - S)Sdt + \sigma Sdz \quad (6)$$

where,  $S'$  is the long-term equilibrium price,  $\eta$  is the reversion speed.

Statistical forecasting models are often complemented with subjective adjustments. Bunn & Wright (1991) distinct two reasons, why statistical models are altered: 1) specification error, when the model has not performed correctly and an adjustment is made to its output and 2) structural change, when some external factor or underlying assumption outside the model will affect the course of future events. Mingers (2006) criticizes purely statistical forecasting methods for their empirical view of world, which oversimplifies real world phenomena. Some authors suggest, however, that the judgmental adjustment may not increase the forecasting accuracy (see, e.g., Carbone, Andersen, Corriveau, & Corson, 1983) and econometric (objective-causal) models perform better in the long-term forecasting compared to subjective-causal expert models (Armstrong & Grohman, 1972). Fildes, Nikolopoulos, Crone, & Syntetos (2008) provide a review of current state of forecasting methods and their use in the OR-literature.

In this research, we have chosen to use statistical GBM- and MR- models, which are enhanced with expert knowledge. As (Bunn & Wright, 1991) write “there are advantages and disadvantages in each approach which are best resolved by allowing *structured* interaction of judgement and statistical forecasting methods”. In summary, the focus of this thesis is on the simulation model development and not on the aspects of how the prices are formed. Therefore the applied SDE-models can be assumed to be generated via the mechanism of updating subjective probability distributions, which do not necessarily relate to supply-demand-storage models.”

### 3 The models created in this research

Two separate models were created for the purposes of this research. The first model is a techno-economic system dynamic model of a metal mine investment, which allows a detailed modeling of a metal mining investment with multiple uncertainties and multiple real options. The presented SD-model extends the boundaries of traditional investment analysis into a more detailed analysis of the technical and the financing aspects of the operations in question. Available mine-specific real options are coded into the model by using a simple “if-else” –logic and they can be activated/de-activated one-by-one, in order to search for an optimal investment configuration. The model is intended to be used for projects already in the pre-feasibility stage, where key technical parameters for the mining system can be set.

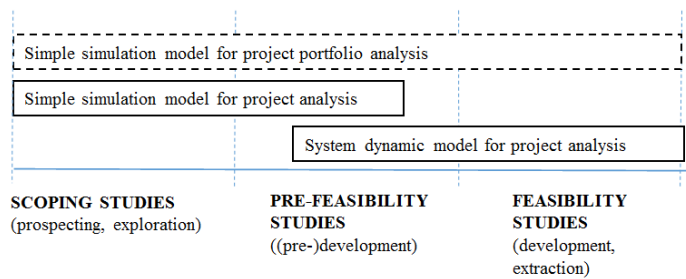

**Figure 7.** Application areas of the developed models on the project timeline of metal mining investments.

The second model is more generic static simulation model that is suitable for a “quick-and-dirty” screening for the value of an individual early stage project under different assumptions of selected key variables. The results produced by the model are rough estimates regarding the potential of valued asset(s). A capability to model the value of postponing the investment decision option is also included. There are two practical purposes envisioned for the model. Firstly, it can be used to perform a simulation based valuation and real option analysis in a decision-making situation that involves acquisition or early development of a metal mining asset. Secondly, it may be used as a portfolio analysis tool in a case of considering multiple different types of metal mining assets as a portfolio (Collan, Savolainen, & Luukka, 2015). The applicability of the developed two models to different project phases is illustrated in Figure 7.

### 3.1 System dynamic model of a metal mining investment

The presented system dynamic model is a generic representation of a real world metal mining investment built in Matlab Simulink®. It imitates the structural features of a metal mining investment in a flexible modeling platform. The construct of the introduced SD-model assumes that a mining operation is actually composed of several subsystems and that the causal relationships between these elements can be presented.

This general model is applicable to a multitude of different situations with case-by-case modifications. It is capable of representing the non-linear behavior of a metal mining investment in a credible way, something that is very difficult to achieve with the commonly in the mining industry used methods. To the best of our knowledge, similar types of models have not been introduced in the earlier literature. Other existing research efforts, which apply principles of system dynamics into feasibility analysis of mining operations include Inthavongsa, Drebenstedt, Bongaerts & Sontamino (2016); Inthavongsa, Sontamino & Drebenstedt (2015) and Sontamino & Drebenstedt (2011, 2014).

The boundaries of feasibility analysis are usually taken as objective, even though in reality they are subjective decisions made by the modeler. The proposed SD-model expands the scope of feasibility analysis into detailed analysis of technical, financing, and social aspects of the metal mining operations. For example, it is common for creditors to impose restrictions (e.g., covenants) for the mine management that restrain their ability to apply for additional funding, or to exercise the available flexibility options. The SD-model has an ability to present these types of “side effects” of decisions in social systems, which are remote in time and space (see discussion (Größler et al., 2008)).

Including the effect of funding in the investment decision making is a rather new idea in the analysis of metal mining investments. Outside the scope of this thesis, we advise to refer to, e.g. Kettunen, Bunn, & Myth (2011) who compare the effect of funding on the investment propensity to different technologies in energy production.

A traditional spreadsheet analysis and the static simulation model introduced in this research, promote the view of production system stability, whereas the SD-model provokes change and adaptation. That is, static analysis models assume a deterministic course of action from the point of initial decision-making forward until the end of decision horizon. The SD-model allows the construction of alternative courses of actions into the model, which are dependent on the realization of uncertainties, which in term change the underlying mechanics of the cash-flow model.

Modeling the range of contingent decision-making alternatives and outcomes is beyond the capabilities of traditional analysis models. That is why the SD-approach should be a

useful tool. As Mitroff (1969) notes a simulation model can be especially valuable, when it is *not* imitating the decision maker, but when it is able to create new alternatives.

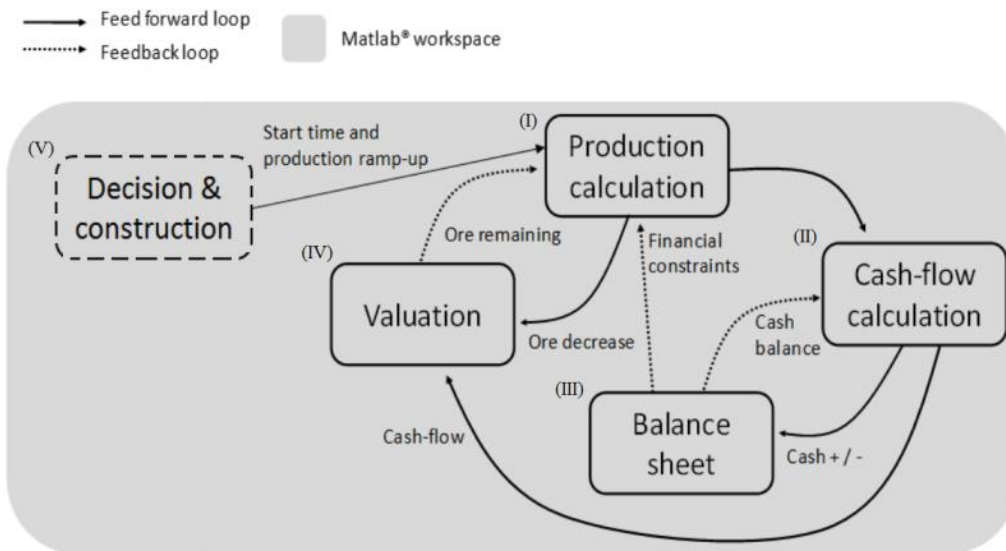

**Figure 8.** An illustration of the created system dynamic model, divided into subsystems with main feedback and feed-forward loops (adopted from Savolainen, Collan, & Luukka (2016b))

The model is hierarchically divided into four to five subsystems. A high-level illustration of the model is shown in Figure 8. A discrete time-step of one month is most often used in the simulations. As the structure of the SD-model is based on subassemblies, its construction can also be reversed by decomposing the model. On the other hand, additional subassemblies may be added. For example, the dynamic formation of the market prices based on, e.g., supply-demand model could be included as a separate subassembly for forecasting prices instead of using SDEs.

Examples of the detailed function block of the diagram are illustrated in Figures 9 and 10, where the laws of interaction are articulated by the arrows between functional blocks. This brings with it an ability to precisely define functional relationships between the values of different constructs.

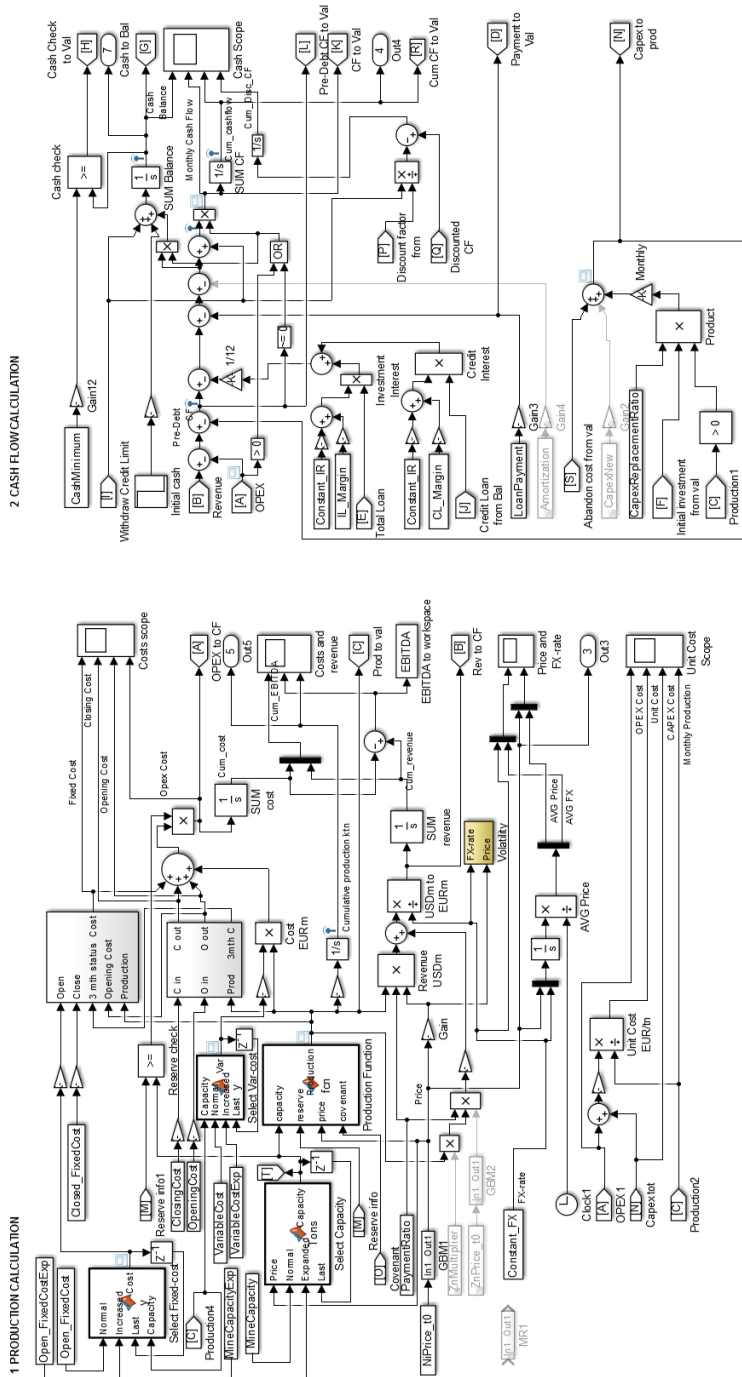

Figure 9. Function block diagrams from SD-model as presented in Savolainen, Collan, & Luukka (2016a). *Left*: Production calculation; *Right*: Cash-flow calculation subsystem.

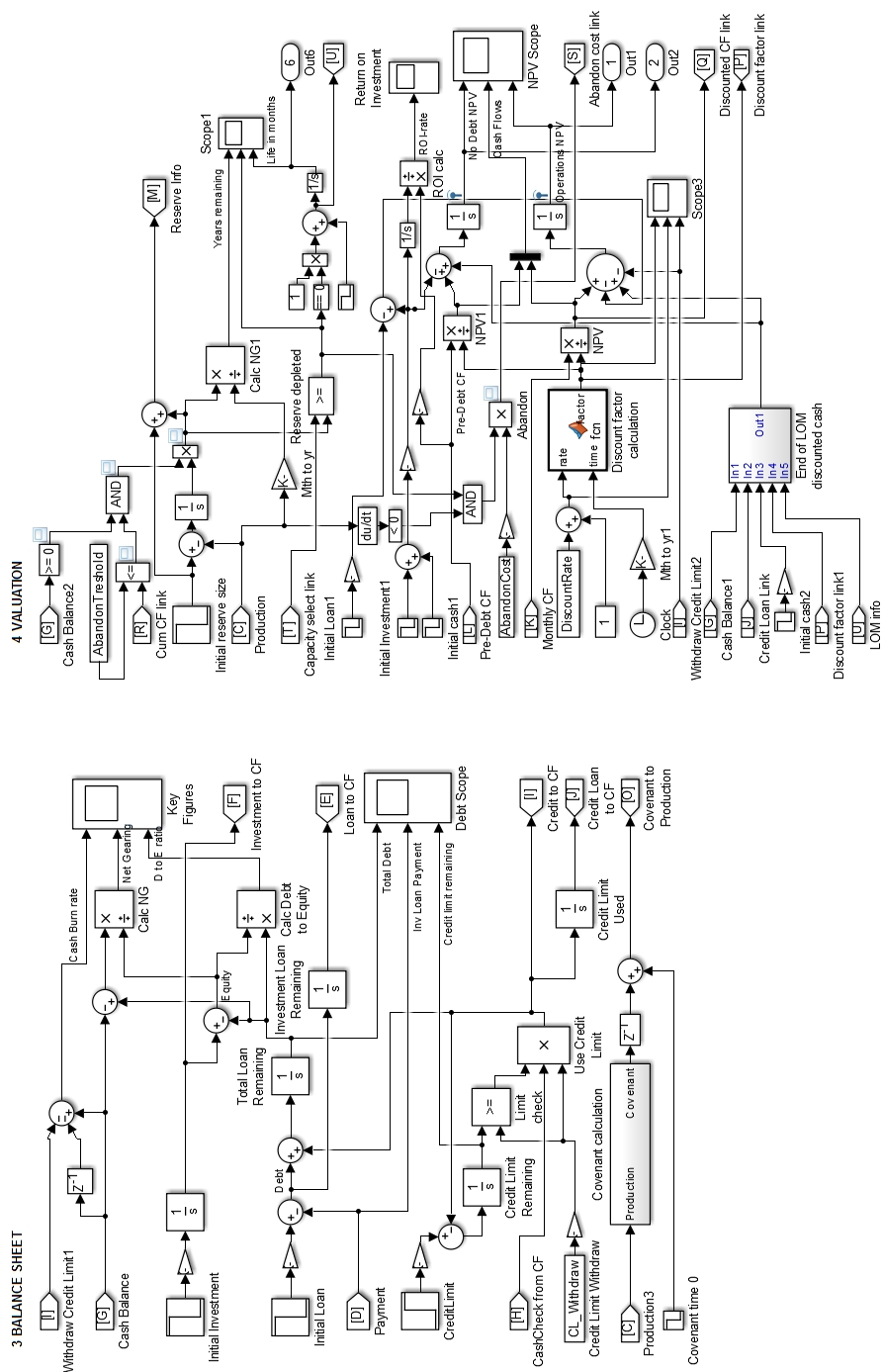

Figure 10. Function block diagrams from SD-model as presented in Savolainen et al. (2016a). Left: Balance sheet; Right: Valuation subsystem.

The main variables and constraints of the model are listed in Table 4.

**Table 4.** List of key input variables and constraints.

VARIABLE	TYPE of variable	UNIT	DETAILS
<i>Project variables</i>			
Investment cost	Independent	M€	-
Building time	Independent	Months	-
Mine capacity	Independent	Tons	Production metal(s)
Fixed cost of operation when open	Independent	M€/month	If production > 0
Fixed cost of operation when closed	Independent	M€/month	If production = 0
Variable cost of production	Independent	€/ton	-
Payment ratio of metal concentrate	Independent	%	Percent of market price
Capital expenditures	Independent	M€/month	-
Abandon cost	Independent	M€	Paid at reserve depletion
Production ramp-up phase	Independent	Months	Time before production = capacity
Ore reserve at project start	Independent	Tons	Metal stock
<i>Market variables</i>			
Metal price(s)	State	\$/ton	-
Exchange rate	State	\$/€	-
Interest rate(s) (incl. margin)	State	%	-
<i>User variables (negotiated)</i>			
Loan at project start	Control	M€	Leverage at project start
Loan payment schedule	Control	M€/month	-
Credit limit at project start	Control	M€	To be used if cash is low
Cash balance at project start	Control	M€	-
Discount rate(s)	Control	%	Subjective; dependent on project
<i>Constraints</i>			
Cash minimum	Control	M€	Has to be > 0
Loan covenant(s)	Control	-	Conditions negotiable
Abandon threshold	Control	-	Conditions negotiable
<i>Target variables (n rounds of simulation)</i>			
Cumulative production	Dependent	tons	Efficiency of resource use
Cumulative cash flow(s)	Dependent	M€	Revenues & costs
Discounted cumulative flow(s)	Dependent	M€	-
TOTAL Net Present Value	Dependent	M€	Not affected by financing
TOTAL Real Option Value	Dependent	M€	"
EQUITY Net Present Value	Dependent	M€	Dependent on financing
EQUITY Real option Value	Dependent	M€	"
NPV(s) < 0 indicator	Dependent	0 or 1	Unfeasible
Abandon trigger indicator	Dependent	0 or 1	"

Independent variables are drawn from probability distributions, as discussed above. The model also allows them to be modeled as state variables, e.g., for a fixed term contract for the payment ratio of metal concentrate, for which conditions are changed periodically.



State variables are considered exogenous. Control variables are typically adjusted within some reasonable limits, e.g., loan and credit limits are not set infinitely large. Dependent variables (see Table 5) indicate the ‘goodness’ of the solution. Note that the model is unlikely to arrive at the mathematical optimum for the dependent variables, but reaches at maximum only a “best available result” within the given constraints of control variables.

**Table 5.** List of target variables.

<i>Target variables</i>			
Cumulative production	Dependent	tons	Efficiency of resource use
Cumulative cash flow(s)	Dependent	M€	Revenues & costs
Discounted cumulative flow(s)	Dependent	M€	-
TOTAL Net Present Value	Dependent	M€	Not affected by financing
TOTAL Real Option Value	Dependent	M€	"
EQUITY Net Present Value	Dependent	M€	Dependent on financing
EQUITY Real option Value	Dependent	M€	"
NPV(s) < 0 indicator	Dependent	0 or 1	Unfeasible plan
Abandon trigger indicator	Dependent	0 or 1	"

Größler et al., (2008) classify two types of feedback loops: negative (goal seeking) and positive (reinforcing). In order to be accurate, the model should have the relevant feedback loops in the system. The most important feedback loops and delays between different subsystems are listed in Table 6.

**Table 6.** List of feedback loops and delays.

FEEDBACK LOOPS	DETAILS		
between sub-processes			
<b>Interactions</b>			
Production & valuation	Production of ore decreases reserve stock		
Production & cash flow	Production generates revenue (positive/negative) and costs		
Cash flow & balance sheet	Cash flow increases/decreases cash stock		
Balance sheet & cash flow	Scheduled loan payments decrease cash flow		
Balance sheet & cash flow	Interest payments decrease cash flow		
Cash flow & valuation	Revenues & costs accumulate into NPV and ROV		
Balance sheet & valuation	Remaining (discounted) initial cash balance at project end is added to NPV		
<b>Optional interactions</b>			
Cash flow & balance sheet	Cash shortage triggers credit limit withdraw		
Valuation & production	Reaching treshold value for abandon stops production permanently		
Balance sheet & valuation	Project leverage changes NPV discount rate		
<b>DELAYS</b>	<b>FROM</b>	<b>TO</b>	<b>DETAILS</b>
Construction time	V	I	Delay before ramp-up starts
Production ramp-up time	V	I	Ramp-up period to full capacity

To value real options with valuation models Trigeorgis (2005, 1993a, 1993b) formulates a simple equation:

$$\text{Real Option Value} = \text{Expanded NPV} - \text{Passive NPV} \quad (3)$$

where the expanded NPV equals the project value with options and the passive NPV is the value of project without options. In the SD-simulations we use equation (3) and typically activate the available real option flexibilities one-by-one to derive the value of different real option combinations. The model mechanics take into account option interactions and the model returns as a result an NPV distribution.

To calculate the value of a real option *on* a project, a logic proposed by Datar & Mathews, 2004 and Mathews & Datar (2007) is applied. This can be formulated as:

$$ROV = (1 - P_n) * NPV_\mu \quad (4)$$

where  $P_n$  is probability of negative outcomes and  $NPV_\mu$  is expected value of the positive NPVs. It is shown in Datar & Mathews (2004) that the numerical approximation of Datar-Mathews (D-M) method converges with the values given by Black & Scholes formula (1973) in a simple example case. It is claimed that D-M method not consistent with financial mathematics, but even so, it does provide a tractable real options methodology to be used in this thesis.

Together, equations (3) and (4) create the foundations of real option valuation technique that is used together with the models. It is notable that the formulae are mutually compatible: that is, for example, an option value of an early stage mining project can be valued and simultaneously take into account its nested managerial flexibilities, such as the value of temporary closure option.

### 3.2 The static simulation model for metal mining investments

The static simulation tool for analyzing metal mining investments is built in the Matlab® Workspace environment by using basic matrix operations. In essence, the static simulation model is a Monte Carlo extension to the traditional NPV-model that is able to add the simultaneous valuation of multiple mines (portfolio effect) and the real option valuation *on* project(s) postponement option. Datar-Mathews logic is applied to estimate the real option value. A single MC-simulation run results in  $n$  alternative project outcomes in terms of NPV, and the results are presented as probability distributions of NPV instead of single numbers. This allows for a more detailed analysis of projects in terms of their risk and return. The modeling procedure for a single mine valuation with the model is illustrated in Figure 11.

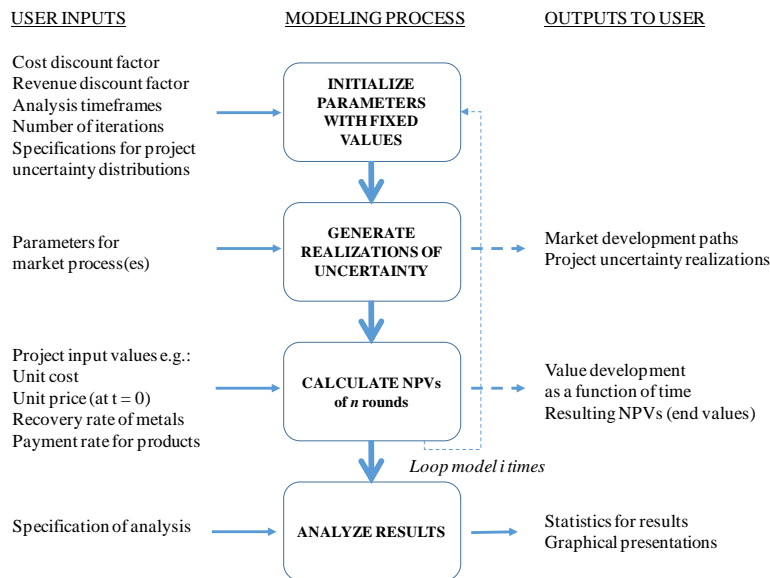

**Figure 11.** A general illustration of the proposed model for valuing early stage mining projects, adopted from (Savolainen, Collan & Luukka, 2015).

The model is robust and applicable to situations, where the available information is limited in terms of accuracy. In other words, when there is no benefit gained from constructing a more detailed SD-model of a metal mining investment in question.

Theoretical basis of the static simulation model for metal mining investments is based on the idea of finite reserve base of any metal mining operation. As any given ore reserve,  $Q$ , is limited in terms of size (i.e.,  $Q < \infty$ ). The initial capacity decision of a mine is a trade-off between designed production capacity,  $P_d$ , the investment cost,  $C_I(P_d)$ , and production unit cost  $C_p(P_d)$ . Theoretically  $P_d$  could be made infinitely large by adding production capacity to infinity (i.e.,  $P_d \rightarrow \infty$  as  $C_I(P_d) \rightarrow \infty$ ), but the investment size is constrained by the reserve size limit  $Q$  and, obviously, by the cost of investment. Other key variables of an early stage mining project include the recovery rate of metal,  $R$ , which theoretically has to be within physically set limits  $0 < R \leq 1$ . Assuming that the output is sold as a metal concentrate, the payment rate,  $\rho$ , is below 100%-grade metal: that is  $0 < \rho \leq 1$ .

The revenue generated in a single metal mine can be written as a function of these uncertain variables. It is a product function of metal price ( $S_m$ ), production rate ( $P_d$ ), recovery rate of the metal ( $R$ ) and the payment rate ( $\rho$ ), discounted by a rate that reflects the both the time value of money and project risk. To complete the NPV-equation of a project, discounted operating costs and the cost of investment have to be deducted from the revenues. Analytically, the NPV-equation of an early stage metal mining project with one output can be written as (Savolainen et al., 2015):

$$NPV = \sum_{t=0}^m \left( \frac{\rho R P_d S_m}{(1+r_{rev})^m} - \frac{C_p(P_d)}{(1+r_{cost})^m} \right) - C_i(P_d) \quad (7)$$

The model is operated under the assumption that the markets are unaffected by the investment decisions of a single company. Thus, to theoretically maximize the value (eq. 7:  $NPV \rightarrow \infty$ ) of a mining operation, one would minimize the investment ( $C_i$ ) and instantly extract an infinite amount ( $P_d$ ) of pure metal ( $\rho$ ,  $R$ ) with no cost ( $C_p$ ) from an infinitely large reserve,  $Q$ . These conditions can be written as:

$$Q \rightarrow \infty, P_d \rightarrow \infty, R \rightarrow 1, \rho \rightarrow 1, C_p(P_d) \rightarrow 0 \text{ and } C_i(P_d) \rightarrow 0 \quad (8)$$

In reality, the optimization has to be done in relation to the ideal operating conditions given in (8). That is, the optimum operation is maximized (7) by:

$$\max NPV(\max[R, P_d, \rho], \min[C_p(P_d), C_i(P_d)]) \quad (9)$$

## 4 The publications and a review of the results

This chapter discusses the objectives set for and the main findings of the six publications, which comprise the second part of the thesis. At the end of this chapter, a summary of the enclosed papers is presented.

Publication 1 is a review paper encompassing the current scientific understanding of quantitative real option analysis within the context of metals mining. Publications 2 introduces the static simulation model and it is used to explore the effects of metal price trends in mining valuation. In publications 3-6 the “larger” SD-model of metal mining investments is introduced and its applicability to real option analysis of metal mining investments is demonstrated using illustrative case examples that study the value of real options in metal mining. The detailed content of each publication is discussed below.

### 4.1 Publication 1: Real options in metal mining project valuation: review of literature

#### *Objective*

The objective of publication 1 was to conduct a literature review regarding the current scientific knowledge of real option analysis of metal mining investments. The idea was to both, provide an overall understanding of the literature, and to identify possible gaps of knowledge. The material consisted of 92 academic research papers mainly from between the years 1995-2015.

#### *Main findings and contributions*

The mining industry specific real options were described in detail as presented in the literature and they were classified by their type. The existing research efforts were summarized on the basis of project type and real option method used. The DCF/NPV-method with, or without real options, and simulation-based real option valuation were found to be the most commonly applied techniques in the valuation of metal mining investments.

The scientific literature on real option analysis of metal mining investments was found to be focused on dealing with very specific decision-making situations with limited number of real options (usually up to two). This finding is in contradiction with the complex nature of metal mining investments and indicates that there is a research gap between the actual detail of the found simulation based analysis models, and the abilities of current modeling techniques applied and the requirements of requisite variety for metal mining investments.

## 4.2 **Publication 2: Using a cycle reverting price process in modeling metal mining project profitability**

### *Objectives*

Empirical research literature (e.g., Chen, 2010; Labys et al., 1999; McClain, Humphreys, & Boscan, 1996; Roberts, 2009; Rossen, 2015; Watkins & McAleer, 2004) suggests that metal markets are “non-ideal” in terms of randomness, and exhibit cycles of different lengths and co-movement of prices. To the best of our knowledge there are very few contributions that attempt to include information on cycles and co-movement of metal prices into project valuation. The objective of this paper is to include managerially estimated characteristics of metal prices (cycles) in the analysis of metal mining investments by combining managerial information with SDE-models.

### *Main findings and contribution*

The static simulation model is used to perform simulations. Managerial estimates on metal price-trends are successfully combined with short-term stochastic modeling of metal prices. The proposed method can also be generalized to other cyclical processes. The results show significant difference in terms of project NPV compared to cases, where only statistically formulated SDEs are used. This result also highlights the importance of price process selection in investment analysis, which is widely discussed in the existing literature.

## 4.3 **Publication 3: Modeling the Profitability of Metal Mining Investments with Real Options as a Dynamic Techno-Economic System**

### *Objectives*

The objective of publication 3 is to demonstrate the applicability of system dynamics as a method for analyzing metal mining investments. System dynamics based simulation analysis is a rather new approach in the real options literature. The SD-model extends the profitability analysis to include the effects of the technical production side and the (availability of) financing for the project. In publication 3 a loan related production covenant is used as a constraint for the operational flexibility. The effect of capital structure and the temporary closure flexibility is studied using an illustrative case of a metal mine project. A single scenario ex-post analysis is run with historical values.

### *Main findings and contribution*

The system dynamic method is shown to be a suitable method for ex-post profitability analysis of complex metal mining investments that contain operational real options. The model allows for requisite variety in the analysis of these investments and provides a more detailed profitability analysis compared to conventional static models. The ex-post

analysis suggests that the investment profitability may be dependent on the form of financing and on the management ability to exercise a temporary closure option.

#### **4.4 Publication 4: Analyzing operational real options in metal mining investments with a system dynamic model**

##### *Objectives*

Publication 4 examines the value effect of three available operating options – namely the temporary closure, expanding the production, and the abandonment of a metal mining investment by using the SD-model. In the current literature on metal mining investments, there are no existing models that would offer a detailed valuation of multiple interacting real options. Effects of the debt ratio used in the investment financing and three different price forecasts are analyzed.

##### *Main findings and contribution*

The SD-model is shown to allow the intuitive modeling of multiple interacting real options, which has been a daunting task using traditional investment analysis models. The approach overcomes the mathematical complexity of earlier proposed solutions as the SD-model closely mimics the construct of a real world metal mining investment.

The importance of selecting the correct price process is, again, highlighted. Project capital structure has a significant effect on project value, a finding that suggests that high-cost operations should not be excessively leveraged. This underlines the importance of “designing” the initial capital structure well and of financial planning in general. Adding multiple real options on a same project does not necessarily increase value.

#### **4.5 Publication 5: Combining system dynamic modeling and the Datar-Mathews method for analyzing metal mine investments**

##### *Objectives*

Demonstrate how metal mining investments can be modelled with system dynamic models and how Datar-Mathews type real option valuation can be integrated with these models. These model types have not been used together in the earlier literature. An illustrative case example of a prospective mining project is analysed from the equity-holder point of view by introducing a dynamic discount rate, which changes linearly as a function of project leverage. In the previous literature the focus has been on the overall value of mining investments, without taking into account its distribution between equity holders and creditors. The use of dynamic discount rate has been previously discussed in the literature by, e.g., Esty (1999), but very few applications exist.

*Main findings and contribution*

Datar-Mathews type of real option analysis is shown to be compatible with SD-models and the use in combination is likely to bring additional benefits to typical Datar-Mathews models. Capital structure and the initial working capital may have an effect on project's value for the equity holder and they should be considered carefully in the initial (profitability) analysis of a metal mining investment.

#### **4.6 Publication 6: On the trade-off between the leverage effect and real options thinking: a simulation-based model on metal mining investment**

*Objectives*

The effects of financing conditions to managerial flexibility (temporary closure in this case) are studied from the point of view of the equity holder. Dynamic discount rate is modeled non-linearly as a function of leverage. The idea of dynamic discount rate is based on the possibility of bankruptcy increases as a function of leverage: McDonald (2013) writes "[a]s the firm becomes more levered, equity-holders bear more asset risk per dollar of equity. If assets have a positive beta, the expected return on equity will increase with leverage". The trade-off between leverage and real option value is discussed. This is a new contribution to existing literature.

*Main findings and contribution*

Flexibility to temporarily shut down the mine increases value in the illustrative case example, but the value of flexibility changes as a function of leverage. This indicates a trade-off between the amount of leverage and the RO-value as the value of investment decreases, when the debt to equity -ratio is increased. Having more debt may force the mining project management to keep the operations running, even though the optimal policy would be to temporarily close the mine. The trade-off between leverage and value of real options underlines the importance of initial financial planning.

#### **4.7 Summary of publications 1-6**

The contributions of individual papers are summarized in Table 6.



Table 6. Summary of the publications.

	Publication I	Publication II	Publication III	Publication IV	Publication V	Publication VI
<b>Title</b>	Real options in metal mining project valuation: review of literature	Using a cycle reverting price process in modeling metal mining project profitability	Modeling the Profitability of Metal Mining investments as a Techno-Economic system	Analyzing operational real options in metal mining investments with a system dynamic model	Combining system dynamic modeling and the Datar-Mathews method for analyzing metal mine investments	Examining the effect of capital structure on the flexibility to temporarily shut down metal mining investments: equity holder's point of view
<b>Objective</b>	Reviewing the existing real option literature on metal mining investments	Inspecting the effect of output prices using managerial estimates of market development	Creating a comprehensive technical economic analysis model for metal mining investments using the principles of system dynamics	Demonstrating the applicability of system dynamic model under multiple uncertainties and several managerial flexibilities (closure, abandon, expand)	Implementing Datar-Mathews method into system dynamic model to attain a real option value of a prospective mining investment from the equity holder's point of view	Modelling the equity holder's point of view in the system dynamic investment model by implementing a debt-ratio dependent revenue discount rate
<b>Research methods</b>	Literature review	Modelling; focus on cycle reversion process of prices	Modelling; focus on creating the system dynamic model	Modelling	Modelling	Modelling
<b>Research data</b>	92 academic research papers, mainly 1995-2015	Illustrative, early stage nickel mine with long 41 years life of mine	Illustrative, operating nickel mine with option to temporary closure, ex-post analysis	Illustrative, operating nickel mine with option to temporary closure and expansion	Illustrative, nickel mine in pre-feasibility analysis phase	Illustrative, nickel mine in pre-feasibility analysis phase with option to temporary closure
<b>Main Results</b>	Real options of metal mining investments are identified and listed. Literature is analyzed on the basis of real option valuation methods used	Including the cyclical nature of metal markets into initial investment analysis has a large effect on the expected value of the investment	The applicability of system dynamic modelling is demonstrated; capital structure is shown to affect the management's ability to exercise operational real options	System dynamic modeling is shown to be able to model the value of complex, mutually dependent operational real options. It is discussed how system dynamic modeling can overcome these valuation issues	Datar-Mathews method is shown to be compatible with system dynamic model; the real option value from the equity holder's point of view is calculated	There is a trade-off between the amount of leverage and real option value



## 5 Discussion and conclusions

This research focuses on the real option valuation of metal mining projects under parametric uncertainty. The main objective has been to “create a generic techno-economic system dynamic model of a metal mining investment and to use it in studying the value of real options”. A literature review was conducted to gain a clear picture of the type of industry specific real options reported in the literature and of the current practice of the valuation of real options in the mining industry.

### 5.1 Answering the research questions

In addition to the two main objectives of the research three research questions were posed. These were answered in the seven publications as shown in table 6. The first research question was formulated as: “does a system dynamic modeling based real option analysis fit metal mining investments?” This question was answered by means of a systematic literature review and further addressed in the publications III-VI focusing on the model development and testing.

The review indicated that the metal mining investments operate under multiple uncertainties and usually more than one real option exists within these assets. It was shown that the current literature mainly deals with simplified case examples of metal mining investments that have a limited number of uncertainties and ROs included in the analysis. This is probably due to the inadequacy of present spreadsheet based models to realistically represent the complexity of a metal mining investment. In this research a system based view was adopted which would allow *requisite variety* between metal mining investments and the applied RO-analysis model.

A follow-up question asked was if there are “possible benefits from using an SD-model in real option valuation compared to the previously existing models” and it was answered in detail in publications III-VI. Additional benefits were found and were listed in publications IV and V as:

- A single model can be used in the detailed modeling of multiple sources of uncertainty, imprecision, and feedback loops, instead of having to consider them in separate analyses
- The modeling of multiple and interacting real options can be performed in SD-modeling without the need of oversimplification the initial decision problem
- Complex mathematical equations derived for the current ROV-models can be presented by application-specific graphical function block diagrams with basic algebra and “if-else” coding

- The type of data used is not restricted in the SD-model: expert opinion-based data and, for example, stochastic processes can simultaneously be incorporated into a same SD-model without compromising the initial data quality

The second research question concerns the effect of a project's capital structure on investment and real option value and this question is studied with the SD-model constructed for the analysis of metal mining investments. On the basis of the findings from publications IV-VI, it seems that under non-ideal circumstances that face the metal mining industry, the capital structure of metal mining investments may matter ("money may matter") unlike the classical finance theory suggests. The choice of financing seems to have an effect on the wealth received by the project owner. This is caused by finding that the value of real options seems to decrease, while the debt-ratio increases: operations may be forced to stay open in order to pay fixed debt-service, even though the optimal policy would be to close temporarily. This means that planning of the use of debt in the context of metal mining investments is of primary importance and the debt pay-back schedule is something that warrants the attention of the parties engaging in metal mining investments.

The final research question addressed the effect of metal price process selection on the investment and real option value of metal mining investments. This research question was investigated within publications II-VI. The obtained results corroborate earlier findings, e.g., Paddock, Siegel, & Smith (1988), where it was shown that the choice of metal price process modeling has a remarkable (important and noticeable) effect on the analysis results. As the role of operational real options may be negligible in the early stage project analysis (as discussed, e.g., by Bjerksund & Ekern 1990; Davis, 1996) and if the major driver of metal mining investment value is the metal price(s). As this is the case, the modeling of metal prices is of high importance.

A follow-up question concerned the mining profitability under the assumption that metal prices are not normally distributed in the long-term. The current scientific literature concerning the historical data acknowledges the existence of market anomalies such as price trends of various lengths and types (see, e.g., Labys et al., 1999; McClain et al., 1996; Rossen, 2015), but as noted by, e.g., Auger & Guzmán (2010) it is unclear how these characteristics should be dealt with in the analysis. This follow-up question was discussed and answers provided in publication II.

In publication II it was suggested that as there is no reliable information available regarding the long-term metal market development in the future, then it may make sense to integrate managerial estimates into the metal price estimation process, this was done by incorporating managerial estimation of the future cycles with stochastic processes.

## 5.2 Managerial and policy implications

The findings presented in this research contribute to the modeling practice of metal mining investments in the presence of real options. The results should be of use of for the managers of mining industry companies involved in making investment decisions. On the basis of this research, it may be suggested that it makes sense to put emphasis on the questions regarding the financing and the debt-servicing schedule of metal mining investments already ex-ante, and to take into consideration the effect of these on the overall profitability of metal mining investments. Also the effect of production based covenants should be investigated ex-ante. The established link between financing and the management ability to exercise real options may in practice lead to a paradoxical situation, where a high cost mine with potential high real option value may also be the most constrained in terms of being able to use the flexibility offered by real options.

The use of metal price processes in the analyses of metal mining investments seems to be of importance and it may make sense to make managerially estimated corrections to long term market forecasts.

The analysis of metal mining investments benefits from using a system dynamics-based modeling approach, because it allows the better capturing of requisite variety for metal mining investments. It can be expected that results received with SD-models are a better representation of reality, than the results received from previously presented models for metal mining investment profitability analysis.

## 5.3 Limitations of the research

### *Model validation and relevance*

Improving performance of a process through theoretical research holds an underlying assumption that the process-models are valid (see Bertrand & Fransoo 2002). In the scope of this thesis, the validity assumption was not put to a test in real life, as discussed in the methodology-chapter. Regarding the validation of models Barlas (1996) separates “behavior validation” and “structure validation” of which the former can be performed with statistical tests. The issue of structure validation is more complex and relates to the philosophy of science issues: “a valid system dynamic model embodies a theory about how a system actually works in some respect” (Barlas, 1996). That is, the conception of model validity is dependent on the underlying philosophy of knowledge (Barlas & Carpenter, 1990).

As a relativistic approach was taken, the model should be evaluated by the user on the basis of usefulness (see discussion Mitroff, 1969). When one considers the statistical

significance, she has to answer the questions for which investigator and for which purpose? The concept of “truth”, “reality” and “verification” have only meaning with respect to the decision maker (Mitroff, 1969). To validate the models built in the course of this thesis would require testing their applicability in “real life” case examples for a longer period time, with testing and model revisions to suit the specific cases. Forrester (1994) suggests that conclusive outcomes cannot be expected even after model implementation, as several changes are likely to occur in the system and its environment.

The economy can be regarded as a process of moving through historical time, which implies that the probability distributions are time dependent, and not under statistical control. To be able to use probability theory, the assumption of replicability of an experiment should hold. However, for macroeconomic functions only a single realization exists, not an “ensemble of macroeconomic worlds”, from which the distribution function could be defined. This makes the applicability of probability based methods highly susceptible if not invalid. (Davidson, 1982). Nevertheless, we feel that the use of probability theory based processes and probability distributions have not jeopardized the validity or credibility of the results herein presented.

#### **5.4 Suggestions for future research**

The validity of SD-models can be best demonstrated by the transferability of insights into reality. In this vein, one of the next avenues of research would be the implementation of the presented models into practice. Practical implementation and adaptation of models should focus also on the education efforts of the local management teams and in this context also the “learnability” and “understandability” of system dynamic models could be studied.

In the optimization efforts of metal mining investment profitability with the SD-model a trial-and-error approach was used in the search for optimal operating policies. Future research efforts will take more advantage from the Matlab® features by creating an automated and a more diverse set of optimization practices. This should not only shorten the computing time used, but also result in better local optima found.

## References

- Abdel Sabour, S. A., Dimitrakopoulos, R. G., & Kumral, M. (2008). Mine design selection under uncertainty. *Mining Technology: IMM Transactions Section A*, 117(2), 53–64. <http://doi.org/10.1179/174328608X343065>
- Abdel Sabour, S., & Dimitrakopoulos, R. (2011). Incorporating geological and market uncertainties and operational flexibility into open pit mine design. *Journal of Mining Science*, 47(2), 191–201. Retrieved from [http://www.researchgate.net/publication/226247998\\_Incorporating\\_geological\\_and\\_market\\_uncertainties\\_and\\_operational\\_flexibility\\_into\\_open\\_pit\\_mine\\_design/file/72e7e52c866ac94fc4.pdf](http://www.researchgate.net/publication/226247998_Incorporating_geological_and_market_uncertainties_and_operational_flexibility_into_open_pit_mine_design/file/72e7e52c866ac94fc4.pdf)
- Abdel Sabour, S., & Poulin, R. (2006). Valuing Real Capital Investments Using The Least-Squares Monte Carlo Method. *The Engineering Economist*, 51(2), 141–160. <http://doi.org/10.1080/00137910600705210>
- Adner, R., & Levinthal, D. A. (2004). What is not a Real Option: Identifying Boundaries for the Application of Real Options to Business Strategy. *Academy of Management Review*, 29, 74–85.
- Amram, M., & Kulatilaka, N. (1999). *Real Options: Managing Strategic Investment in an Uncertain World*. Boston, Massachusetts: President and Fellows of Harvard College.
- Armstrong, J. S., & Grohman, M. C. (1972). A Comparative Study of Methods for Long-Range Market Forecasting. *Management Science*, 19(2), 211–221. <http://doi.org/10.1287/mnsc.19.2.211>
- Ashby, W. (1958). Requisite variety and its implications for the control of complex systems. *Cybernetica*, 1:2, 83–99. Retrieved from <http://pcp.vub.ac.be/Books/AshbyReqVar.pdf>
- Auger, F., & Guzmán, J. I. (2010). How rational are investment decisions in the copper industry? *Resources Policy*, 35(4), 292–300. <http://doi.org/10.1016/j.resourpol.2010.07.002>
- Azimi, Y., Osanloo, M., & Esfahanipour, A. (2013). An uncertainty based multi-criteria ranking system for open pit mining cut-off grade strategy selection. *Resources Policy*, 38(2), 212–223. <http://doi.org/10.1016/j.resourpol.2013.01.004>
- Barlas, Y. (1996). Formal aspects of model validity and validation in system dynamics. *System Dynamics Review*, 12(3), 183–210. [http://doi.org/10.1002/\(SICI\)1099-1727\(199623\)12:3<183::AID-SDR103>3.0.CO;2-4](http://doi.org/10.1002/(SICI)1099-1727(199623)12:3<183::AID-SDR103>3.0.CO;2-4)
- Barlas, Y., & Carpenter, S. (1990). Philosophical roots of model validation: two paradigms. *System Dynamics Review*, 6(2), 148–166. <http://doi.org/10.1002/sdr.4260060203>
- Bartrop, S., & White, A. (1995). Spade work - how miners value resources. *JASSA*, (March), 7–13.
- Bengtsson, J. (2001). Manufacturing flexibility and real options: A review. *International Journal of Production Economics*, 74(1–3), 213–224. [http://doi.org/10.1016/S0925-5273\(01\)00128-1](http://doi.org/10.1016/S0925-5273(01)00128-1)
- Bernanke, B. (1983). Irreversibility, Uncertainty, and Cyclical Investment. *The Quarterly Journal of Economics*, 98(1), 85–106.

- Bertrand, J. W. M., & Fransoo, J. C. (2002). Operations management research methodologies using quantitative modeling. *International Journal of Operations & Production Management*, 22(2), 241–264. <http://doi.org/10.1108/01443570210414338>
- Bhappu, R. R., & Guzman, J. (1995). Mineral Investment Decision Making: Study of Practices. *Engineering & Mining Journal*.
- Bjerkstrand, P., & Ekern, S. (1990). Managing Investment Opportunities under Price Uncertainty: From “Last Chance” to “Wait and See” Strategies. *Financial Management*, 19(3), 65–83. Retrieved from <http://www.jstor.org/stable/3665826?origin=JSTOR-pdf>
- Black, F., & Scholes, M. (1973). The Pricing of Options and Corporate Liabilities. *The Journal of Political Economy*, 81(3), 637–654.
- Botín, J. A., Del Castillo, M. F., Guzmán, R. R., & Smith, M. L. (2012). *Real options: A tool for managing technical risk in a mine plan* (SME Annual Meeting No. Preprint 12-121; Feb. 19-22, 2012, Seattle, WA). Retrieved from [http://www.researchgate.net/publication/221787956\\_REAL\\_OPTIONS\\_A\\_Tool\\_for\\_Managing\\_Technical\\_Risk\\_in\\_a\\_Mine\\_Plan](http://www.researchgate.net/publication/221787956_REAL_OPTIONS_A_Tool_for_Managing_Technical_Risk_in_a_Mine_Plan)
- Botin, J., Del Castillo, M. F., & Guzman, R. (2013). A real options application to manage risk related intrinsic variables of a mine plan: a case study on Chuquicamata Underground Mine Project. *The Journal of Southern African Institute of Mining and Metallurgy*, 113(July), 583–592.
- Boyle, P. P. (1977). Options: A Monte Carlo approach. *Journal of Financial Economics*, 4(3), 323–338. [http://doi.org/10.1016/0304-405X\(77\)90005-8](http://doi.org/10.1016/0304-405X(77)90005-8)
- Brennan, M. J., & Schwartz, E. S. (1985a). A New Approach to Evaluating Natural Resource Investments. *Midland Corporate Finance Journal*, 3(1), 42–47.
- Brennan, M. J., & Schwartz, E. S. (1985b). Evaluating Natural Resource Investments. *The Journal of Business*, 58(2), 135–157.
- Bunn, D., & Wright, G. (1991). Interaction of judgmental and statistical forecasting methods: issues & analysis. *Management Science*, 37(5), 501–518.
- Cairns, R. D. (1998). The Microeconomics of Mineral Extraction Under Capacity Constraints. *Nonrenewable Resources*, 7(3), 233–244.
- Carbone, R., Andersen, A., Corriveau, Y., & Corson, P. P. (1983). Comparing for Different Time Series Methods the Value of Technical Expertise Individualized Analysis, and Judgmental Adjustment. *Management Science*, 29(5), 559–566. <http://doi.org/10.1287/mnsc.29.5.559>
- Casassus, J., & Collin-Dufresne, P. (2005). Stochastic Convenience Yield Implied from Commodity Futures and Interest Rates. *The Journal of Finance*, 60(5), 2283–2331.
- Cavender, B. W. (1998). Does the capital budgeting process inhibit corporate competitiveness? *Mining Engineering*, 50(12), 57–64. Retrieved from <http://cat.inist.fr/?aModele=afficheN&cpsid=9889060>
- Chen, M. H. (2010). Understanding world metals prices>Returns, volatility and diversification. *Resources Policy*, 35(3), 127–140. <http://doi.org/10.1016/j.resourpol.2010.01.001>
- CIMVAL. (2003). *Standards and Guidelines for Valuation of Mineral Properties*. Retrieved from



[http://web.cim.org/standards/documents/Block487\\_Doc69.pdf](http://web.cim.org/standards/documents/Block487_Doc69.pdf)

- Coldwell, D., Henker, T., Ho, J., & Fong, K. (2003). Real Options Valuation of Australian Gold Mines and Mining Companies. *Journal of Alternative Investments*, 6(1), 23–38.
- Collan, M., Fullér, R., & Mezei, J. (2009). A Fuzzy Pay-off Method for Real Option Valuation. *Journal of Applied Mathematics and Decision Sciences*, 2009, 1–14. <http://doi.org/10.1155/2009/238196>
- Collan, M., Hahtela, T., & Kyläheiko, K. (2016). On the usability of real option valuation model types under different types of uncertainty Kalevi Kyläheiko. *International Journal of Business Innovation and Research*, 11(1), 18–37. <http://doi.org/10.1504>
- Collan, M., Savolainen, J., & Luukka, P. (2015). Screening the value of a mining asset portfolio - A simulation approach. In M. Collan & P. Luukka (Eds.), *Proceedings of the ROW15 – Real Option Workshop, August 18.-19., 2015* (pp. 4–12). Lappeenranta, Finland: Lappeenranta Finland, LUT Scientific and Research Publications, Research Reports, 44, CreateSpace Inc., USA. Retrieved from <http://www.roworkshop.org/wp-content/uploads/2015/07/ROW15-proceedings.pdf>
- Cortazar, G., & Casassus, J. (1998). Optimal timing of a mine expansion: Implementing a real options model. *The Quarterly Review of Economics and Finance*, 38(3), 755–769. [http://doi.org/10.1016/S1062-9769\(99\)80100-8](http://doi.org/10.1016/S1062-9769(99)80100-8)
- Cortazar, G., Gravet, M., & Urzua, J. (2008). The valuation of multidimensional American real options using the LSM simulation method. *Computers & Operations Research*, 35(1), 113–129. <http://doi.org/10.1016/j.cor.2006.02.016>
- Costa Lima, G. A., & Suslick, S. B. (2006). Estimating the volatility of mining projects considering price and operating cost uncertainties. *Resources Policy*, 31(2), 86–94. <http://doi.org/10.1016/j.resourpol.2006.07.002>
- Cox, J. C., Ross, S. a., & Rubinstein, M. (1979). Option pricing: A simplified approach. *Journal of Financial Economics*, 7(3), 229–263. [http://doi.org/10.1016/0304-405X\(79\)90015-1](http://doi.org/10.1016/0304-405X(79)90015-1)
- Crowson, P. (2012). Some observations on copper yields and ore grades. *Resources Policy*, 37(1), 59–72. <http://doi.org/10.1016/j.resourpol.2011.12.004>
- Datar, V., & Mathews, S. (2004). European real options: An intuitive algorithm for the Black-Scholes formula. *Journal of Applied Finance*, 14, 7–13. Retrieved from [http://papers.ssrn.com/sol3/papers.cfm?abstract\\_id=560982](http://papers.ssrn.com/sol3/papers.cfm?abstract_id=560982)
- Davidson, P. (1982). Rational expectations: a fallacious foundation for studying crucial decision-making processes. *Journal of Post Keynesian Economics*, 5(2), 182–198.
- Davidson, P. (1991). Is probability theory relevant for uncertainty? a Post Keynesian perspectives. *Journal of Economic Perspectives*, 5(1), 129–143.
- Davis, G. A. (1996). Option premiums in mineral asset pricing: are they important? *Land Economics*, 72(2), 167–186. Retrieved from <http://www.jstor.org/stable/10.2307/3146964>
- De Magalhaes Ozorio, L., Shevchenko, P. V., & De Lamare Bastian-Pinto, C. (2013). *The Choice of Stochastic Process in Real Option Valuation II: Selecting Multiple Factor Models* (Real Options 17th Annual International Conference). Retrieved from <http://www.realoptions.org/openconf2013/data/papers/32.pdf>

- de Neufville, R. (2003). Real options: dealing with uncertainty in systems planning and design. *Integrated Assessment*, 4(1), 26–34. Retrieved from [http://ardent.mit.edu/real\\_options/Real\\_opts\\_papers/delftpaperpublication.pdf](http://ardent.mit.edu/real_options/Real_opts_papers/delftpaperpublication.pdf)
- Dehghani, H., & Ataee-pour, M. (2012). Determination of the effect of operating cost uncertainty on mining project evaluation. *Resources Policy*, 37(1), 109–117. <http://doi.org/10.1016/j.resourpol.2011.11.001>
- Dias, M. A. G. (2006). *Real Options Theory for Real Asset Portfolios : the Oil Exploration Case. 10th Annual International Conference on Real Options, June 14-17, 2006*. New York City USA. Retrieved from <http://citeseerx.ist.psu.edu/viewdoc/download?doi=10.1.1.136.4012&rep=rep1&type=pdf>
- Dimitrakopoulos, R., Farrelly, C. T., & Godoy, M. (2002). Moving forward from traditional optimization: grade uncertainty and risk effects in open-pit design. *Mining Technology*, 111(1), 82–88. Retrieved from <http://www.maneyonline.com/doi/abs/10.1179/mnt.2002.111.1.82>
- Dimitrakopoulos, R. G., & Abdel Sabour, S. a. (2007). Evaluating mine plans under uncertainty: Can the real options make a difference? *Resources Policy*, 32(3), 116–125. <http://doi.org/10.1016/j.resourpol.2007.06.003>
- Dosi, G., & Egidi, M. (1991). Substantive and procedural uncertainty. An exploration of economic behaviors in changing environments. *Evolutionary Economics* 1, 1(2), 24.
- Dowd, P. (1994). Risk assessment in reserve estimation and open-pit planning. *Transactions of The Institution of Mining and Metallurgy*, (January), 148–154. [http://doi.org/10.1016/0148-9062\(95\)97056-O](http://doi.org/10.1016/0148-9062(95)97056-O)
- Driouchi, T., & Bennett, D. J. (2012). Real Options in Management and Organizational Strategy: A Review of Decision-making and Performance Implications. *International Journal of Management Reviews*, 14(1), 39–62. <http://doi.org/10.1111/j.1468-2370.2011.00304.x>
- Emshoff, J. R. (1978). Experience-Generalized Decision Making: The Next Generation of Managerial Models. *Interfaces*, 8(4), 40–48.
- Esty, B. C. (1999). Improved techniques for valuating large scale projects. *The Journal of Project Finance*, Spring, 9–25.
- Eves, C. (2013). The valuation of long life mines: Current issues and methodologies. In *19th Annual Pacific-Rim Real Estate Society Conference Melbourne Australia, 13-16 January 2013* (pp. 1–17). Retrieved from [http://www.pres.net/papers/Eves\\_The\\_Valuation\\_Of\\_Long\\_Life\\_Mines\\_Current\\_Issues\\_And\\_Methodologies.pdf](http://www.pres.net/papers/Eves_The_Valuation_Of_Long_Life_Mines_Current_Issues_And_Methodologies.pdf)
- Fildes, R., Nikolopoulos, K., Crone, S. F., & Syntetos, A. A. (2008). Forecasting and operational research: a review. *Journal of the Operational Research Society*, 59(9), 1150–1172. <http://doi.org/10.1057/palgrave.jors.2602597>
- Forrester, J. W. (1961). *Industrial Dynamics*. Cambridge, MA: The MIT Press.
- Forrester, J. W. (1994). System Dynamics, Systems Thinking , and Soft OR. *Systems Dynamics Review*, 10(Summer-Fall), 245–256.

- Frimpong, S., & Whiting, J. M. (1997). Derivative mine valuation: strategic investment decisions in competitive markets. *Resources Policy*, 23(4), 163–171. [http://doi.org/10.1016/S0301-4207\(97\)00029-9](http://doi.org/10.1016/S0301-4207(97)00029-9)
- Geman, H. (2005). *Commodities and Commodity Derivatives: Modeling and Pricing for Agriculturals, Metals and Energy*. Chichester: John Wiley & Sons.
- Giaglis, G. M. (2001). A Taxonomy of Business Process Modelling and Information Systems Modelling Techniques. *International Journal of Flexible Manufacturing Systems*, 13(2), 209–228.
- Gibson, R., & Schwartz, E. (1990). Stochastic convenience yield and the pricing of oil contingent claims. *The Journal of Finance*. <http://doi.org/10.1111/j.1540-6261.1990.tb05114.x>
- Groeneveld, B., & Topal, E. (2011). Flexible open-pit mine design under uncertainty. *Journal of Mining*, 47(2), 212–226.
- Größler, A., Thun, J.-H., & Milling, P. M. (2008). System dynamics as a structural theory in operations management. *Production and Operations Management*, 17(3), 373–384. <http://doi.org/10.3401/poms.1080.0023>
- Guimaraes Dias, M. A., & Carlos Rocha, K. M. (1999). *Petroleum Concessions With Extensible Options Using Mean Reversion With Jumps to Model Oil Prices*. 3rd Annual Real Options Conference. Retrieved from <http://realoptions.org/papers1999/MarcoKatia.pdf>
- Guj, P., & Garzon, R. (2007). *Modern Asset Pricing — A Valuable Real Option Complement to Discounted Cash Flow Modelling of Mining Projects*. Project Evaluation Conference. Melbourne, Vic.
- Haque, M. A., Topal, E., & Lilford, E. (2014). A numerical study for a mining project using real options valuation under commodity price uncertainty. *Resources Policy*, 39, 115–123. <http://doi.org/10.1016/j.resourpol.2013.12.004>
- Herath, H. S. B., & Park, C. S. (2002). Multi-Stage Capital Investment Opportunities as Compound Real Options. *The Engineering Economist*, 47(1), 1–27.
- Herrero de Egaña, A., Soria Bravo, C., & Muñoz Cabanes, A. (2016). On the Separability of Real and Financial Decisions. *International Advances in Economic Research*, 22, 211–224. <http://doi.org/10.1007/s11294-016-9578-8>
- Hopper, T., & Powell, A. (1985). Making sense of research into the organizational and social aspects of management accounting: A review of its underlying assumptions. *Journal of Management Studies*, 22(5), 429–465. <http://doi.org/10.1111/j.1467-6486.1985.tb00007.x>
- Humphreys, D. (1996). Comment. New approaches to valuation: a mining company perspective. *Resources Policy*, 22, 75–77.
- IMA. (2008). Definition of Management Accounting. Retrieved February 25, 2016, from <http://www.imanet.org/docs/default-source/research/sma/definition-of-mangement-accounting.pdf?sfvrsn=2>
- IMVAL. (2015). *International mineral property valuation standards template*.
- Inthavongsa, I., Drebenstedt, C., Bongaerts, J., & Sontamino, P. (2016). Real options decision framework: Strategic operating policies for open pit mine planning. *Resources Policy*, 47, 142–153.

<http://doi.org/10.1016/j.resourpol.2016.01.009>

- Inthavongsa, I., Sontamino, P., & Drebenstedt, C. (2015). A Prototype of Real Options Valuation Framework for Open Pit Mines Planning: A Road to Build a Dynamics Decision Making Tools. In *Proceedings of 24th International Mining Congress and Exhibition of Turkey. IMCET'2015, Antalya, Turkey, April 14-17, 2015* (pp. 646–654).
- JORC. (2012). *Australasian Code for Reporting of Exploration Results, Mineral Resources and Ore Reserves*. Retrieved from [http://www.jorc.org/docs/JORC\\_code\\_2012.pdf](http://www.jorc.org/docs/JORC_code_2012.pdf)
- Järvinen, P. (2000). Research questions guiding selection of an appropriate research method. In Hansen, Bichler, & Mahrer (Eds.), *Proceedings of the European Conference on Information Systems 2000, 3-5 July*. (pp. 124–131). Vienna: Vienna University of Economics and Business Administration.
- Kenzap, S. A., & Kazakidis, V. N. (2013). Operating risk assessment for underground metal mining systems : overview and discussion. *International Journal of Mining and Mineral Engineering*, 4(3), 175–200. <http://doi.org/10.1504/IJMME.2013.053167>
- Kettunen, J., Bunn, D. W., & Myth, W. (2011). Investment propensities under carbon policy uncertainty. *Energy Journal*, 32(1), 77–117. <http://doi.org/10.5547/ISSN0195-6574-EJ-Vol32-No1-4>
- Klossek, P., & Klossek, A. (2014). The Specific Value of Junior Mining Companies: Are Common Valuation Methods Appropriate? *Journal of Business Valuation and Economic Loss Analysis*, 9(1), 105–144. <http://doi.org/10.1515/jbvela-2013-0014>
- Kuchta, D. (2000). Fuzzy capital budgeting. *Fuzzy Sets and Systems*, 111, 367–385.
- Kyläheiko, K. (1998). Making sense of technology: Towards a synthesis between neoclassical and evolutionary approaches. *International Journal of Production Economics*, 56–57, 319–332.
- Labys, W. C., Achouch, A., & Terraza, M. (1999). Metal prices and the business cycle. *Resources Policy*, 25, 229–238. [http://doi.org/10.1016/S0301-4207\(99\)00030-6](http://doi.org/10.1016/S0301-4207(99)00030-6)
- Lander, D. M., & Pinches, G. E. (1998). Challenges to the practical implementation of modeling and valuing real options. *The Quarterly Review of Economics and Finance*, 38(3), 537–567. [http://doi.org/10.1016/S1062-9769\(99\)80089-1](http://doi.org/10.1016/S1062-9769(99)80089-1)
- Langlois, R. N. (1984). Internal Organization in a Dynamic Context: Some Theoretical Considerations. In M. Jussawalla & H. Ebenfield (Eds.), *Communication and Information Economics: New Perspectives* (Vol. 49, pp. 23–49). Amsterdam: North-Holland. Retrieved from <http://web.uconn.edu/ciom/Internal.pdf>
- Laughton, D. (2007). The Banff Taxonomy of Asset Valuation Methods : Lessons from Financial Markets for Real Asset Valuation in the Upstream Petroleum Industry. Retrieved January 26, 2016, from [http://davidlaughtonconsulting.ca/docs/banff\\_taxonomy.pdf](http://davidlaughtonconsulting.ca/docs/banff_taxonomy.pdf)
- Lawrence, M. J., & Dewar, G. J. A. (1999). Mineral Property Valuation, or “What Number Did You Have in Mind.” In *PACRM '99* (pp. 13–27). Bali, Indonesia.
- Lawson, T. (1988). Probability and uncertainty in economic analysis. *Journal of Post Keynesian Economics*, 11(1), 38–65.
- Lin, C.-G., & Wang, Y.-S. (2012). Evaluating natural resource projects with embedded options and limited

- reserves. *Applied Economics*, 44(12), 1471–1482. <http://doi.org/10.1080/00036846.2010.543076>
- Longstaff, F. A., & Schwartz, E. S. (2001). Valuing American Options by Simulation : A Simple Least-Squares Approach. *The Review of Financial Studies*, 14(1), 113–147.
- Martinez, L. A., & McKibben, J. (2010). Understanding Real Options in Perspective Mine Project Valuation : A Simple abstract discounted cash flow analysis for mine project valuation. In *Minin 2010* (pp. 223–234). Santiago, Chile.
- Mathews, S., & Datar, V. (2007). A Practical Method for Valuing Real Options: The Boeing Approach. *Applied Corporate Finance*, 19(2), 95–104. <http://doi.org/10.1007/978-1-4614-9173-6>
- Mathews, S., & Salmon, J. (2007). Business Engineering: A Practical Approach to Valuing High-Risk, High-Return Projects Using Real Options. *INFORMS Tutorials in Operations Research*, 157–175. <http://doi.org/10.1287/educ.1073>
- Mayer, Z., & Kazakidis, V. (2007). Decision making in flexible mine production system design using real options. *Journal of Construction Engineering and Management*, (February), 169–181. Retrieved from [http://ascelibrary.org/doi/abs/10.1061/\(ASCE\)0733-9364\(2007\)133:2\(169\)](http://ascelibrary.org/doi/abs/10.1061/(ASCE)0733-9364(2007)133:2(169))
- McCallum, J. S. (1987). The Net Present Value Method: Part of our Investment Problem. *Business Quarterly*, 52(2), 7–9.
- McClain, K. T., Humphreys, H. B., & Boscan, A. (1996). Measuring risk in the mining sector with ARCH models with important observations on sample size. *Journal of Empirical Finance*, 3, 369–391. [http://doi.org/10.1016/S0927-5398\(96\)00006-0](http://doi.org/10.1016/S0927-5398(96)00006-0)
- McDonald, R. L. (2013). *Derivatives Markets* (3rd ed.). Pearson.
- McDonald, R. L., & Siegel, D. R. (1985). Investment and valuation of firms when there is an option to shut down. *International Economic Review*, 26(2), 331–349.
- Miller, L. T., & Park, C. S. (2002). Decision Making Under Uncertainty - Real Options to the Rescue. *The Engineering Economist*, 47(2), 105–150.
- Mingers, J. (2006). A Critique of Statistical Modelling in Management Science from a Critical Realist Perspective: Its Role Within Multimethodology. *The Journal of the Operational Research Society*, 57(2), 202–219. <http://doi.org/10.1057/palgrave.jors.2601980>
- Mitroff, I. I. (1969). Fundamental Issues In The Simulation Of Human Behavior : A Case In The Strategy Of Behavioral Science. *Management Science*, 15(12), 635–650.
- Mitroff, I. I., Betz, F., Pondy, L. R., & Sagasti, F. (1974). On Managing Science in the Systems Age: Two Schemas for the Study of Science as a Whole Systems Phenomenon. *Interfaces*, 4(3), 46–58. <http://doi.org/10.1287/inte.4.3.46>
- Modigliani, F., & Miller, M. H. (1958). The Cost of Capital, Corporation Finance and the Theory of Investment. *The American Economic Review*, 48(3), 261–297. <http://doi.org/10.4013/base.20082.07>
- Moyen, N., Slade, M., & Uppal, R. (1996). Valuing risk and flexibility A comparison of methods. *Resources Policy*, 22, 63–74.
- Mukherjee, T. K., & Henderson, G. V. (1987). *The Capital Budgeting Process: Theory and Practice*.

- Interfaces*, 17(2), 78–90. <http://doi.org/10.1287/inte.17.2.78>
- Myers, S. C. (1977). Determinants of corporate borrowing. *Journal of Financial Economics*, 5, 147–175. [http://doi.org/10.1016/0304-405X\(77\)90015-0](http://doi.org/10.1016/0304-405X(77)90015-0)
- Newman, A. M., Rubio, E., Caro, R., Weintraub, A., & Eurek, K. (2010). A Review of Operations Research in Mine Planning. *Interfaces*, 40(3), 222–245. <http://doi.org/10.1287/inte.1090.0492>
- NI 43-101. NI 43-101 - Standards of disclosure for mineral projects (2011). Canada: Ontario Securities Commission. Retrieved from [http://web.cim.org/standards/documents/Block484\\_Doc111.pdf](http://web.cim.org/standards/documents/Block484_Doc111.pdf)
- Paddock, J. L., Siegel, D. R., & Smith, J. L. (1988). Option valuation of claims on real assets: the case of offshore petroleum leases. *The Quarterly Journal of Economics*, 103(3), 479–508.
- Park, H. M., & Nelson, M. G. (2013). Mining project evaluation process for investment decisions: Risk variables in mining projects - part one. *Mining Engineering*, 65(10), 18–21.
- Pindyck, R. S. (1999). The long-run evolution of energy prices The Long-Run Evolution of Energy Prices. *The Energy Journal*, 20(2), 1–27. [http://doi.org/10.1016/S0140-6701\(99\)91409-1](http://doi.org/10.1016/S0140-6701(99)91409-1)
- Pindyck, R. S., & Rotemberg, J. J. (1990). The excess co-movement of commodity prices. *The Economic Journal*, 100, 1173–1189.
- Roberts, M. C. (2009). Duration and characteristics of metal price cycles. *Resources Policy*, 34(3), 87–102. <http://doi.org/10.1016/j.resourpol.2009.02.001>
- Roscoe, W. E. (2002). Valuation of Mineral Exploration Properties Using the Cost Approach. *CIM Bulletin*, 95(1059), 11. Retrieved from [http://web.cim.org/mes/pdf/VALDAYBill\\_Roscoe.pdf](http://web.cim.org/mes/pdf/VALDAYBill_Roscoe.pdf)
- Ross, J. G. (2004). Risk and uncertainty in portfolio characterisation. *Journal of Petroleum Science and Engineering*, 44(1–2), 41–53. <http://doi.org/10.1016/j.petrol.2004.02.004>
- Rossen, A. (2015). What are metal prices like? Co-movement, price cycles and long-run trends. *Resources Policy*, 45, 255–276. <http://doi.org/10.1016/j.resourpol.2015.06.002>
- Ryan, P. A., & Ryan, G. P. (2002). Capital Budgeting Practices of the Fortune 1000: How Have Things Changed? *Journal of Business & Management*, 8(4), 15. Retrieved from <http://search.ebscohost.com.ezproxy.liv.ac.uk/login.aspx?direct=true&db=bth&AN=9533066&site=eds-live&scope=site>
- Samis, M., Martinez, L., Davis, G. A., & Whyte, J. B. (2012). Using dynamic DCF and real option methods for economic analysis in NI43-101 technical reports. In *The Valmin Seminar Series 2011-12 Proceedings* (pp. 149–160). The Australian Institute of Mining and Metallurgy, Publication Series No 3/2012. Retrieved from <http://inside.mines.edu/~gdavis/Papers/ValMin.pdf>
- SAMVAL. (2009). *The South African code for the reporting of mineral asset valuation (The SAMVAL code)*. Retrieved from <http://www.samcode.co.za/downloads/SAMVAL2009.pdf>
- Savolainen, J., Collan, M., & Luukka, P. (2015). Screening early stage metal mining projects - A simulation approach. In A. Szakál (Ed.), *Proceedings on INES 2015 - IEEE 19th International Conference on Intelligent Engineering Systems. September 3-5* (pp. 231–236). Bratislava, Slovakia: IEEE Hungary Section.

- Savolainen, J., Collan, M., & Luukka, P. (2016a). Analyzing operational real options in metal mining investments with a system dynamic model. *The Engineering Economist*, 20. JOUR. <http://doi.org/10.1080/0013791X.2016.1167988>
- Savolainen, J., Collan, M., & Luukka, P. (2016b). Combining system dynamic modeling and the Datar-Mathews method for analyzing metal mine investments. *Acta Universitatis Palackianae Olomucensis. Facultas Rerum Naturalium. Matematika, Unpublishe*.
- Schwartz, E. S. (1998). Valuing Long-Term Commodity Assets. *Journal of Energy Finance & Development*, 3(2), 85–99. <http://doi.org/10.2307/3666151>
- Schwartz, E. S. (2013). The Real Options Approach to Valuation: Challenges and Opportunities. *Latin American Journal of Economics*, 50(2), 163–177. <http://doi.org/10.7764/LAJE.50.2.163>
- Simon, H. A. (1962). The Architecture of Complexity. *Proceedings of the American Philosophical Society*, 106(6), 467–482. <http://doi.org/10.2307/985254>
- Singhvi, S. S., & Lambrix, R. J. (1984). Investment Versus Financing Decisions. *Management Accounting*, 65(9), 54–56.
- Slade, M. (2001). Valuing managerial flexibility: An application of real-option theory to mining investments. *Journal of Environmental Economics and Management*, 41, 193–233. Retrieved from <http://www.sciencedirect.com/science/article/pii/S0095069600911392>
- Smith, J. E., & McCardle, K. F. (1999). Options in the Real World: Lessons Learned in Evaluating Oil and Gas Investments. *Operations Research*, 47(1), 1–15. <http://doi.org/10.1287/opre.47.1.1>
- Smith, J. E., & Nau, R. F. (1995). Valuing Risky Projects: Option Pricing Theory and Decision Analysis. *Management Science*, 41(5), 795–816. <http://doi.org/10.1287/mnsc.41.5.795>
- Smith, L. D. (2002). Discounted Cash Flow Analysis Methodology and Discount Rates. *CIM Bulletin*, 95(1062), 101–108.
- Sontamino, P., & Drebenstedt, C. (2011). Decision Support System of Coal Mine Planning Using System Dynamics Model: Introduction and Reviews. In *6th Freiberg-St. Petersburg Kolloquium junger Wisseshafiler 15-17 Juni 2011, Freiberg, Germany* (pp. 1–6). Retrieved from [http://www.researchgate.net/publication/233959780\\_Decision\\_Support\\_System\\_of\\_Coal\\_Mine\\_Planning\\_Using\\_System\\_Dynamics\\_Model\\_Introduction\\_and\\_Reviews/file/9fcfd50d56cd10a622.pdf](http://www.researchgate.net/publication/233959780_Decision_Support_System_of_Coal_Mine_Planning_Using_System_Dynamics_Model_Introduction_and_Reviews/file/9fcfd50d56cd10a622.pdf)
- Sontamino, P., & Drebenstedt, C. (2014). A Prototype Decision Making Tool of a Coal Mine Planning Using System Dynamics Model. In C. Drebenstedt & R. Singhal (Eds.), *Mine Planning and Equipment Selection*. Cham: Springer International Publishing. <http://doi.org/10.1007/978-3-319-02678-7>
- The VALMIN Committee. (2015). *The VALMIN Code 2015 edition*. Retrieved from [www.valmin.org/docs/VALMIN\\_Code\\_2015\\_final.pdf](http://www.valmin.org/docs/VALMIN_Code_2015_final.pdf)
- Triantis, A. (2005). Realizing the Potential of Real Options: Does Theory Meet Practice? *Journal of Applied Corporate Finance*, 17(2), 8–16.
- Trigeorgis, L. (1993a). Real Options and Interactions With Financial Flexibility. *Financial Management, Autumn*, 202–224.

- Trigeorgis, L. (1993b). The Nature of Option Interactions and the Valuation of Investments with Multiple Real Options. *The Journal of Financial and Quantitative Analysis*, 28(1), 1–20.
- Trigeorgis, L. (2005). Making Use of Real Options Simple: an Overview and Applications in Flexible/Modular Decision Making. *The Engineering Economist*, 50, 25–53. <http://doi.org/10.1080/00137910590917026>
- Truex, D. P., Baskerville, R., & Klein, H. (1999). Growing Systems in Emergent Organizations. *Communications of the ACM*, 42(8), 117–123.
- Tsekrekos, A. E., Shackleton, M. B., & Wojakowski, R. (2012). Evaluating Natural Resource Investments under Different Model Dynamics: Managerial Insights. *European Financial Management*, 18(4), 543–575. <http://doi.org/10.1111/j.1468-036X.2010.00544.x>
- Tufano, P. (1998). The Determinants of Stock Price Exposure: Financial Engineering and the Gold Mining Industry. *The Journal of Finance*, 53(3), 1015–1052. <http://doi.org/10.1111/0022-1082.00042>
- Wallace, S. W. (1998). Decision making under uncertainty: Is sensitivity analysis of any use? *Operations Research*, 48(1), 2000.
- Wand, Y., & Wang, R. Y. (1996). Anchoring Data Quality Dimensions in Ontological Foundations. *Communications of the ACM*, 39(11), 86–95.
- Watkins, C., & McAleer, M. (2004). Non-Ferrous Metal Prices. *Journal of Economic Surveys*, 18(5), 651–702. <http://doi.org/10.1111/j.1467-6419.2004.00233.x>
- Weber, R. (2003). Theoretically Speaking. *MIS Quarterly*, 27(3), 3–12.





## ACTA UNIVERSITATIS LAPPEENRANTAENSIS

693. NORONTAUS, ANNUKKA. Oppisopimuskoulutus yritysten tuottamana koulutuspalveluna: tavoitteista vaikutuksiin. 2016. Diss.
694. HALMINEN, OSKARI. Multibody models for examination of touchdown bearing systems. 2016. Diss.
695. TALONPOIKA, ANNA-MARIA. Financial working capital – management and measurement. 2016. Diss.
696. INKINEN, HENRI. Intellectual capital, knowledge management practices and firm performance. 2016. Diss.
697. YANG, XIAOCHEN. Development of a welding production quality control and management system model for China. 2016. Diss.
698. LEMINEN, VILLE. Leak-proof heat sealing of press-formed paperboard trays. 2016. Diss.
699. LAAKSONEN, LAURI. Spectral retinal image processing and analysis for ophthalmology. 2016. Diss.
700. OINONEN, MINNA. Management of customer co-development in business-to-business markets. 2016. Diss.
701. ALATALO, SARA-MAARIA. Hydrothermal carbonization in the synthesis of sustainable porous carbon materials. 2016. Diss.
702. UZHEGOV, NIKITA. Design and material selection of high-speed rotating electrical machines. 2016. Diss.
703. RICHTER, CHRIS. Digital collaborations and entrepreneurship – the role of shareconomy and crowdsourcing in the era of smart city. 2016. Diss.
704. JAFARI, SHILA. Investigation of adsorption of dyes onto modified titanium dioxide. 2016. Diss.
705. PATEL, YOGINI. Computational modelling of non-equilibrium condensing steam flows in low-pressure steam turbines. 2016. Diss.
706. LEVCHUK, IRINA. Titanium dioxide based nanomaterials for photocatalytic water treatment. 2016. Diss.
707. AMOUR, IDRISSE. Variational ensemble kalman filtering applied to data assimilation problems in computational fluid dynamics. 2016. Diss.
708. SHESTAKOVA, MARINA. Ultrasound-assisted electrochemical treatment of wastewaters containing organic pollutants by using novel Ti/Ta<sub>2</sub>O<sub>5</sub>-SnO<sub>2</sub> electrodes. 2016. Diss.
709. OLEKSIENKO, OLGA. Physico-chemical properties of sol-gel synthesized titanosilicates for the uptake of radionuclides from aqueous solutions. 2016. Diss.
710. PATALA, SAMULI. Advancing sustainability-oriented innovations in industrial markets. 2016. Diss.
711. KUORIKOSKI, TERO. Kohti resonoivaa urheilujohtamista – Tavoitteen muodostuminen urheilun kentässä. 2016. Diss.

712. LAHTELA, VILLE. Improving the properties of solid Scots pine (*Pinus sylvestris*) wood by using modification technology and agents. 2016. Diss.
713. NEVARANTA, NIKO. Online time and frequency domain identification of a resonating mechanical system in electric drives. 2016. Diss.
714. FANG, CHAO. Study on system design and key technologies of case closure welding for ITER correction coil. 2016. Diss.
715. GARCÍA PÉREZ, MANUEL. Modeling the effects of unsteady flow patterns on the fireside ash fouling in tube arrays of kraft and coal-fired boilers.
716. KATTAINEN, JARI. Heterarkkisen verkostoyhteistyön johtamistarpeet verkoston muotoutumisvaiheessa. 2016. Diss.
717. HASAN, MEHDI. Purification of aqueous electrolyte solutions by air-cooled natural freezing. 2016. Diss.
718. KNUTAS, ANTTI. Increasing beneficial interactions in a computer-supported collaborative environment. 2016. Diss.
719. OVASKA, SAMI-SEPPO. Oil and grease barrier properties of converted dispersion-coated paperboards. 2016. Diss.
720. MAROCHKIN, VLADISLAV. Novel solutions for improving solid-state photon detector performance and manufacturing. 2016. Diss.
721. SERMYAGINA, EKATERINA. Modelling of torrefaction and hydrothermal carbonization and heat integration of torrefaction with a CHP plant. 2016. Diss.
722. KOTISALO, KAISA. Assessment of process safety performance in Seveso establishments. 2016. Diss.
723. LAINE, IGOR. Institution-based view of entrepreneurial internationalization. 2016. Diss.
724. MONTECINOS, WERNER EDUARDO JARA. Axial flux permanent magnet machines – development of optimal design strategies. 2016. Diss.
725. MULTAHARJU, SIRPA. Managing sustainability-related risks in supply chains. 2016. Diss.
726. HANNONEN, JANNE. Application of an embedded control system for aging detection of power converter components. 2016. Diss.
727. PARKKILA, JANNE. Connecting video games as a solution for the growing video game markets. 2016. Diss.
728. RINKINEN, SATU. Clusters, innovation systems and ecosystems: Studies on innovation policy's concept evolution and approaches for regional renewal. 2016. Diss.
729. VANADZINA, EVGENIA. Capacity market in Russia: addressing the energy trilemma. 2016. Diss.
730. KUOKKANEN, ANNA. Understanding complex system change for a sustainable food system. 2016. Diss.

