

ABSTRACT

Lappeenranta University of Technology
LUT School of Energy Systems
LUT Mechanical Engineering

Richard Anandaraj Rajan

Green Welding in Practice

Master's Thesis

2015

113 Pages, 27 Figures and 16 Tables

Examiners: Professor Jukka Martikainen
 Associate Professor Paul Kah

Keywords: Green welding, smart welding power source, advanced welding, newly developed materials, intelligent welding, welding data management, fume emission control.

Efficient production and consumption of energy has become the top priority of national and international policies around the world. Manufacturing industries have to address the requirements of the government in relation to energy saving and ecologically sustainable products. These industries are also concerned with energy and material usage due to their rising costs. Therefore industries have to find solutions that can support environmental preservation yet maintain competitiveness in the market. Welding, a major manufacturing process, consumes a great deal of material and energy. It is a crucial process in improving a product's life-cycle cost, strength, quality and reliability. Factors which lead to weld related inefficiencies have to be effectively managed, if industries are to meet their quality requirements and fulfil a high-volume production demand. Therefore it is important to consider some practical strategies in welding process for optimization of energy and material consumption. The main objective of this thesis is to explore the methods of minimizing the ecological footprint of the welding process and methods to effectively manage its material and energy usage in the welding process. The author has performed a critical review of the factors including improved weld power source efficiency, efficient weld techniques, newly developed weld materials, intelligent welding systems, weld safety measures and personnel training. The study lends strong support to the fact that the use of eco-friendly welding units and the quality weld joints obtained with minimum possible consumption of energy and materials should be the main directions of improvement in welding systems. The study concludes that, gradually implementing the practical strategies mentioned in this thesis would help the manufacturing industries to achieve on the following - reduced power consumption, enhanced power control and manipulation, increased deposition rate, reduced cycle time, reduced joint preparation time, reduced heat affected zones, reduced repair rates, improved joint properties, reduced post-weld operations, improved automation, improved sensing and control, avoiding hazardous conditions and reduced exposure of welder to potential hazards. These improvement can help in promotion of welding as a green manufacturing process.

TABLE OF CONTENTS

ABSTRACT	2
LIST OF SYMBOLS AND ABBREVIATIONS	5
LIST OF FIGURES	7
LIST OF TABLES	9
1 INTRODUCTION	10
1.1 Goal of the thesis:	11
1.2 Outline of the thesis	12
2 WELDING PROCESS CONTRIBUTION TOWARDS GREEN MANUFACTURING	15
2.1 Development in Welding Power Sources	15
2.1.1 Characteristics of smart power source systems	21
2.1.2 Eco-Welding design.....	23
2.2 Developments in Gas Metal Arc Welding (GMAW).....	23
2.2.1 Pulsed-Gas Metal Arc Welding (P-GMAW).....	27
2.2.2 Cold Metal Transfer (CMT).....	29
2.2.3 Double Electrode Gas Metal Arc Welding (DE-GMAW).....	31
2.2.4 Tandem-Gas Metal Arc Welding (T-GMAW)	32
2.2.5 Alternating Current - Gas Metal Arc Welding (AC-GMAW).....	33
2.3 Developments in Friction Stir Welding (FSW).....	34
2.3.1 Friction Stir Spot Welding (FSSW).....	37
2.3.2 Reverse dual-rotation friction stir welding (RDR-FSW).....	38
2.4 Developments in Hybrid Welding Process.....	38
2.5 Developments in Gas Tungsten Arc Welding (GTAW)	40
2.5.1 Arcing-wire GTAW	40
2.5.2 Pulsed Gas Tungsten Arc Welding (P-GTAW).....	40
2.6 Progress with Submerged Arc Welding (SAW).....	41
2.6.1 Double Electrode-Submerged Arc Welding (DE-SAW).....	42
2.7 Developments in Laser Beam Welding (LBW)	42
2.7.1 Remote Laser Welding Technology (RLW).....	44

3	ADVANCED MATERIAL CONTRIBUTION TOWARDS GREEN	
	MANUFACTURING.....	46
3.1	Developments in Power Plant applications	46
3.2	Developments in Aerospace applications.....	48
3.3	Developments in Oil and Gas applications.....	52
3.4	Developments in Shipbuilding applications	53
3.5	Developments in Automotive applications.....	54
3.6	Developments in Mining Industries.	56
3.7	Developments in Offshore applications	57
3.8	Development in Process Industries.....	59
4	INTELLIGENT WELDING SYSTEM CONTRIBUTION TOWARDS GREEN	
	MANUCATURING	60
4.1	Developments in Robotic and Automated Welding Systems.....	60
4.1.1	Articulating Weld Robots	60
4.1.2	Industrial Weld Positioners.....	62
4.2	Developments in Weld Monitoring Systems.....	66
4.2.1	Welding as a Complex Process.....	67
4.2.2	Weld Data Sensing.....	68
4.2.3	Weld Data Management	73
4.3	Future Trends in Intelligent Welding Systems	75
5	WELDING SAFETY MEASURES CONTRIBUTION TOWARDS GREEN	
	MANUFACTURING.....	77
5.1	Fume Formation Mechanism.....	78
5.2	Fume Emission Control	80
5.2.1	Integral Fume Extraction Torches	82
5.2.2	Exhaust Ventilations Systems.....	83
5.2.3	Personal Protective Equipment	85
6	PERSONNEL TRAINING CONTRIBUTION TOWARDS GREEN	
	MANUFACTURING.....	87
7	CONCLUSIONS AND DISCUSSIONS.....	89
8	SUMMARY	95
	REFERENCES.....	97

LIST OF SYMBOLS AND ABBREVIATIONS

AC	Alternating Current
AC-GMAW	Alternating Current - Gas Metal Arc Welding
AHSS	Advanced High Strength Steel
AWS	American Welding Society
CAD	Computer Aided Drawing
CC	Constant Current
CMT	Cold Metal Transfer
CO ₂	Carbon dioxide
CTOD	Crack Tip Open Displacement
CV	Constant Voltage
DC	Direct Current
DCEN	Direct Current Electrode Negative
DCEP	Direct Current Electrode Positive
DE-GMAW	Double Electrode-Gas Metal Arc Welding
DE-SAW	Double Electrode-Submerged Arc Welding
DP	Dual Phase
DP-GMAW	Double Pulsed Gas Metal Arc Welding
EC	European Commission
EN	European Standard
EU	European Union
EFW	European Welding Federation
FCAW	Flux Cored Arc Welding
FFR	Fume Formation Rate
FSW	Friction Stir Welding
GMAW	Gas Metal Arc Welding
GTAW	Gas Tungsten Arc Welding
HLAW	Hybrid Laser Arc Welding
HSLA	High-Strength Low-Alloy
HSLC	High-Strength Low-Carbon
IEC	International Electro technical commission
IF	Interstitial Free

IF AHSS	Interstitial-Free Advanced High-Strength Steels
IGBT	Insulated Gate Bipolar Transistor
IMC	Inter-Metallic Compounds
IR	Infra-Red
LBW	Laser Beam Welding
LTTW	Low Transformation Temperature welding
MMA	Manual Metal Arc Welding
MMC	Metal Matrix Composites
M_s	Martensite transformation start temperature
NASA	National Aeronautics and Space Administration
Nd:YAG	Neodymium-doped Yttrium Aluminium Garnet
OSHA	Occupational Safety and Health Administration
PAPR	Powered Air Purifying Respirators
P-GMAW	Pulsed Gas Metal Arc Welding
P-GTAW	Pulsed-Gas Tungsten Arc Welding
PPE	Personal Protective Equipment
RDR-FSW	Reverse Dual Rotation-Friction Stir Welding
RLW	Remote Laser Welding
RSW	Resistant Spot Welding
SAW	Submerged Arc Welding
SCR	Silicon Controlled Rectifier
SMSS	Super-Martensitic Stainless Steels
SZ	Stir Zone
T-GMAW	Tandem-Gas Metal Arc Welding
TS	Tensile Strength
TWI	The Welding Institute
UV	Ultraviolet
X-ray	X-radiation

LIST OF FIGURES

Figure 1: Main components in the AC/DC inverter power source (Larry, 2012).	16
Figure 2: Idling power consumption for different welding power supply types (Bird, 1993).	16
Figure 3: Different pulse waveforms of P-GMAW to achieve better penetration (Praveen, et al., 2005).	19
Figure 4: GMAW process equipment. Modified from (Stewart & Lewis, 2013).....	24
Figure 5: GMAW process control system with feedback control of welding voltage and current (ESAB and AGA, 1999).....	24
Figure 6: Basic principle (a), setup (b) and typical metal transfer (c) in laser enhanced GMAW (Huang & Zhang, 2010; Huang, et al., 2012).	26
Figure 7: Basic principle (a) and typical metal transfer (b) in ultrasonic wave enhanced GMAW (Fan, et al., 2012).	26
Figure 8: Comparison between conventional arc process and the one-sided arc technique (Kimoto & Motomatsu, 2007).	27
Figure 9: Current waveform of double-pulsed GMAW (Celina & Américo, 2006).	29
Figure 10 : Power–current diagram with CMT process area of application. (Lorenzina & Rutilib, 2009)	30
Figure 11: The basic setup of DE-GMAW process (Lua, et al., 2014).	32
Figure 12: Comparison of current waveforms of P-GMAW with AC-GMAW (Nabeel & Hyun, 2014).	34
Figure 13: Schematics of the friction stir welding process (Mishra & Ma, 2005).	35
Figure 14: Schematic representation of friction stir spot welding (Koen, 2015).	38
Figure 15: Schematics of the hybrid laser arc welding process (Paul, 2013).	39
Figure 16: Pulse GTAW process parameter (Madadi, et al., 2012).	41
Figure 17: Working principle of remote laser welding (Robert & Marianna, 2011), (Tracey & David, 2013).	45
Figure 18: Effect of oxygen content in weld metal on the percentage of brittle fracture at -74°C for Charpy impact test (SMAW) (Kitagawa & Kawaski, 2013).	58
Figure 19: Robotic welding machines with heavy load carrying capacity of up to 500kgs (ABB, 2015).....	61

Figure 20: Illustration of artificial decomposition of complex system for effective monitoring and control (Zhang, 2008).....	67
Figure 21: Illustration of the processes involved in human welder’s behaviour (Zhang & Zhang, 2012).....	75
Figure 22: Illustration of intelligent welding machine that replicates human welder’s behaviour (Liu, et al., 2014).	75
Figure 23: Variation of fume formation rate (FFR) with the current intensity for GMAW process with different gas shielding mixtures studied (Pires, et al., 2007).....	80
Figure 24: Fume extraction torch restrict the reach of fumes to the welders (Deanna, 2015).	82
Figure 25: The low vacuum/high volume mobile unit has an extendable arm for easier positioning (Miller Welds, 2015).....	83
Figure 26: The modular extraction hood with attached filtration unit for gas reusability (Millerwelds, 2015).	84
Figure 27: The powered air-purifying respirator contains hard case helmet with air purifying unit (Miller, 2015).....	86

LIST OF TABLES

<i>Table 1: Comparison of conventional and modern power source designs (Praveen, et al., 2005).</i>	18
<i>Table 2: Efficiency of arc welding machines (Karsten, et al., 2014).</i>	18
<i>Table 3: Transformation of AC-GTAW with evolution of power source technology (Robert & Jeff, 2013).</i>	21
<i>Table 4: Characteristics of a smart power source system.</i>	22
<i>Table 5: Benefits of the FSW Process (Nandan, et al., 2008).</i>	36
<i>Table 6: Suggested methods to improve the toughness in the welded material (Kitagawa & Kawaski, 2013).</i>	54
<i>Table 7 : Different types of positioners available in the market (1/3) (David, 2014).</i>	63
<i>Table 8 : Different types of positioners available in the market (2/3) (David, 2014).</i>	64
<i>Table 9 : Different types of positioners available in the market (3/3) (David, 2014).</i>	65
<i>Table 10: Various sensors used for obtaining information from the weld pool (Zhang, 2008).</i>	66
<i>Table 11: Different techniques used in weld monitoring systems (1/4). (Zhang, 2008; Na, 2008; Ma & Zhang, 2011; Zhang, et al., 2012)</i>	69
<i>Table 12: Different techniques used in weld monitoring system (2/4) (Zhang, 2008; Na, 2008; Ma & Zhang, 2011; Zhang, et al., 2012).</i>	70
<i>Table 13: Different techniques used in weld monitoring systems (3/4) (Zhang, 2008; Na, 2008; Ma & Zhang, 2011; Zhang, et al., 2012).</i>	71
<i>Table 14: Different techniques used in weld monitoring systems (4/4) (Zhang, 2008; Na, 2008; Ma & Zhang, 2011; Zhang, et al., 2012).</i>	72
<i>Table 15: Common usage of the interpreted data from the weld monitoring systems (Todd, 2012).</i>	74
<i>Table 16: Common Weld Safety Hazards (Cary & Helzer, 2005).</i>	77

1 INTRODUCTION

Welding plays an important role in our daily life. It is one of the most effective ways to join metals. The structural frames in the building are welded, so are the trains, planes and automobiles; pipelines which ensures constant supply of gas, water, electricity; housewares including the furniture to the cutlery items; are all welded. The list goes on. Huge army of robotic welding machines and skilled professionals carry out these welding activities. Efficient production and consumption of energy has become a critical issue around the world fuelled by rising population, depletion of fossil fuel sources and detrimental impacts on the environment. As a result of increase in demand for energy consumption, carbon-dioxide emissions are expected to increase significantly by approximately 46%, from 31 billion metric tons in 2010 to 45 billion metric tons in 2040. (DuPont, 2014) These factors denote the need for efficient production and consumption of energy and material. Welding, which is one of the widely used manufacturing process, consumes a great deal of material and energy (Purslow, 2012). It is a crucial process in improving a components life-cycle cost, strength, quality and reliability. Therefore engineers face the distinctive task of solving the challenges posed by government regulations and the demands of owner's representatives.

Green Manufacturing process - A process which eliminates the environmental burden at different stages of manufacturing yet remain economic and competitive in the market. Green manufacturing process conforms to the environmental standards and substantially reduce material and energy consumption. In-order to refer welding as a green process, the activities related to welding need to be aimed at reducing the ecological footprint right from the input to the output stage. Work safety, cost-effective weld operations, reduced material wastage and high quality joints obtained with minimum possible consumption of energy and material should be the main research areas in welding process development. (Lebedev, et al., 2014)

In EU and rest of the world, implementation of the new environmental, health and safety laws have created the demands for effective welding methods which promote a safe and productive work environment. Traditional welding techniques have become hazardous and costly with the introduction of these laws; however it is possible to significantly improve

these aspects by employing some of the advanced process developments. The pressure to remain competitive in the business has created situations where manufacturing industries are required to operate economically. The ongoing effort among manufacturing and fabrication industries is to maintain control over their costs and increase their productivity thereby securing a competitive edge in the growing market; the main goal of these industries. They have to be competitive in their timelines for completion while keeping up in pricings to meet the financial budgets. As soon as the contract is approved for a project, companies face extreme pressure from many sides to complete the project in time and budget. The faster a job can be completed, of course the better, the bottom line. Therefore companies hold on to one important measurable function – efficiency. Efficiency of the process is crucial to the final decision, when welding professionals compare between the welding processes for process selection. Deposition efficiency and energy efficiency is critical in determining the suitability of the welding technique for a particular project. Industries require operational efficiencies to regulate process flow and limit unscheduled downtime of automated equipment. Factors leading to process inefficiencies need to be effectively identified and managed, if industries are to meet their quality requirements yet fulfil a high-volume production demand. Industries can adopt the concept of ‘maximum results (both economically and ecologically) from minimum resources’ rather than the concept of ‘maximum profit from minimum capital’. This attitude will help in the promotion of research on ‘green manufacturing techniques’. Therefore it is important to consider some practical strategies for optimization of energy and material requirements for the welding process.

1.1 Goal of the thesis:

The main goal of the thesis is to explore welding related activities which can help reduce its ecological footprint. The study focuses on the practical methods in welding process which would help the manufacturing industries to achieve on the following:

- Reduced power consumption
- Enhanced power control and manipulation
- Increased deposition rate
- Reduced cycle time
- Reduced joint preparation time
- Reduced heat affected zones

- Reduced repair rates
- Improved joint properties
- Reduced post-weld operations
- Improved automation
- Improved sensing and control
- Avoiding hazardous situations from operator
- Reduced exposure of potential hazards to welder.

These improvement can help in promotion of welding as a green manufacturing process.

1.2 Outline of the thesis

In this thesis the recent advancements in weld related activities which helps reduce the environmental burden are explained. The developments either directly or indirectly helps in minimizing the ecological impact of welding. For example the inverter based power supply systems are highly energy efficient therefore energy consumption is significantly minimized and operating costs can be saved. This is a direct example of minimizing the ecological impact. Another example is, Cold Metal Transfer (CMT) process, which is capable of producing very low heat-input welds, low residual stresses and spatter-free welds when compared with conventional fusion process. This example is an indirect way of contributing to the green process because the advantages mentioned above reduces loss in mechanical properties of material and unnecessary post-weld operations (stress relieving heat treatment, fixtures to avoid distortions and Grinding for removing spatter). These factors indirectly minimizes the energy and material consumption.

In the first part, the evolution of the welding power source technology is discussed and then the advancement in welding processes are explained. Conventional welding processes have been tremendously improved with the introduction of modern electronic equipment (Pires, 1996). Significant improvements in welding characteristics and ecological aspects have been made possible with implementation of algorithms to control inverter based welding power supplies (Lebedev & Maksimov, 2012; Lebedev, et al., 2014). The transformation and achievements of the welding power source technology have been reviewed. Welding technologies with very high productivity, reduced post-weld operations, minimum consumption of energy and minimum damage to the metal is very attractive in the field of welding. Post-weld heat treatment process are highly energy intensive process which are

performed at high temperatures for longer period of times. Therefore reduced post-weld operations are highly appreciated among industries. Significant improvements in the ecological aspects and weld characteristic improvements of selected welding processes (Friction stir welding (FSW), Hybrid welding, Gas metal arc welding (GMAW), Gas Tungsten arc welding (GTAW), Submerged arc welding (SAW), Laser beam welding (LBW)) have been reviewed.

In the second part, the recent developments in implementing advanced material combinations and consumables in the manufacturing industries have been discussed. The growing concerns on issue of energy saving and environmental conservations has considerably increased the demand of lightweight structures for automobiles, aircraft, and ships. Similarly, the increasing need for the energy resources has driven the energy industries into deeper and colder seas, in search of oil and gas resources. In-order to meet such demanding applications, materials capable of withstanding extreme temperature variations, high pressure are constantly developed with strict quality requirements that would allow them to remain stable on a lasting basis. Joining dissimilar multi-material assemblies have been of significant and growing interests. Advancements in filler metals have been achieved to offer both the chemical and mechanical composition necessary to match the materials, and also the characteristics needed to achieve quality welds, reduced rework and of course increased productivity.

In the third part, the productivity enhancing innovations in automated welding systems or intelligent welding systems have been discussed. The benefits of the advancements in control and sensor technologies are tremendous. Weld data monitoring systems can effectively track the productivity of the welding system. Precise and accurate weld monitoring systems used before, during and after welding process are developed to significantly improve the automated process control through effective feedback systems. The evolution in manufacturing technologies has helped robotic units working together to carry out diversified functions in a more synchronized manner. Increased confidence in the resultant weld with desired quality has been achieved with computational modelling, as they predict accurately key weld characteristics for a given set of control parameters.

In the last part, practical methods that effectively restrict the reach of welder to the fumes and other welding related hazards have been discussed. Although the welding environment of the past had been perceived to be dark, dirty and dangerous due to the nature of the work, the recent government regulations, changing business practices and increasing environmental awareness have driven the manufacturing environment to be a quieter, cleaner, healthier, safer and friendlier place for workers. However solutions for completely restricting the welder's exposure to welding fumes and harmful gases have not been made possible. Health aspects related to welding are complex subjects and so industries invest on researches for finding a cost-effective solution that could minimize the health related hazards of the process. Many researches have been made to evaluate the effects of the welder's exposure to typical constituents of welding fumes and gases, as well as its impact on the environment. The revision of exposure limits has constricted allowable lower limits of toxic substances during welding and the decreasing trend can be expected to continue in the coming years with the increasing rules and regulations.

2 WELDING PROCESS CONTRIBUTION TOWARDS GREEN MANUFACTURING

Rapid advancements in arc welding technology present opportunities for significantly increasing the welding productivity for weld operations ranging from very thin sheet weld joints to very thick section butt weld joints. Welding speed and productivity improvements are linked to significant cost saving results in the manufacturing industries. New welding techniques have been developed to enhance GMAW process with more control over the weld pool. The variants of GMAW can demonstrate their ability to successfully weld thin sheet plates, dissimilar joint and metal sensitive to heat input and also they have achieved significant reduction in heat input, sparks and smoke.

2.1 Development in Welding Power Sources

From the early days of its introduction, the main function of the power sources had been to supply/control the current and voltage, required for welding (Praveen, et al., 2005). In the early 1990s, insulated gate bipolar transistors (IGBTs) were introduced with an operational range of 20kHz. However today, IGBTs work in the range of 80-120kHz. Weld power source technology has gone through tremendous transformation in the past years with innovations in the electronic industries. With these advancements they promise a highly reliable and mature technology to control the source power.

The conventional power sources were highly simple and robust in nature and used the in-phase regulator type transistorized power systems that utilize the paralleled connector banks of small power transistors. High design cost, bulky water cooling units and very limited arc manipulation features are its main drawbacks (Praveen, et al., 2005). Inverter technology, however, improved the portability and significantly reduced power consumption compared to them. Figure 1 shows the components involved in an AC/DC inverter. The complex process which takes place in an inverter based power supply can be simplified as follows. The 50/60 Hz AC power from the electric grid at high voltage is converted from AC to DC, which is then passed through the IGBT to convert back to AC with frequency ranges of 20,000 to 80,000 Hz and 10 to 80V. The AC is again converted to DC welding output. In order to obtain control over the welding process, the control circuitries actuates the IGBTs

which in-turn manipulates the power output to achieve desired characteristics i.e. Constant Current (CC) or Constant Voltage (CV) or Alternating Current (AC) or Direct Current (DC). The inverter transistor technology has tremendously reduced the consumption of energies during welding and idling time. (Larry, 2012; Purslow, 2012; Selco, 2015) Figure 2 explains the power consumption of the welding equipment while idling with three different power supply types.

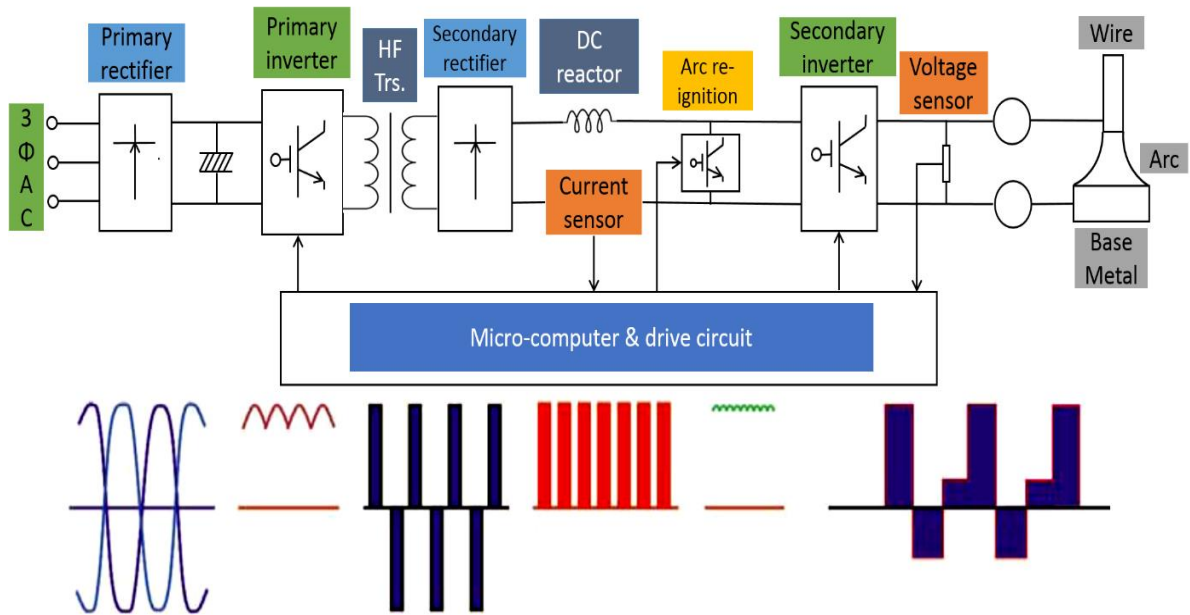

Figure 1: Main components in the AC/DC inverter power source (Larry, 2012).

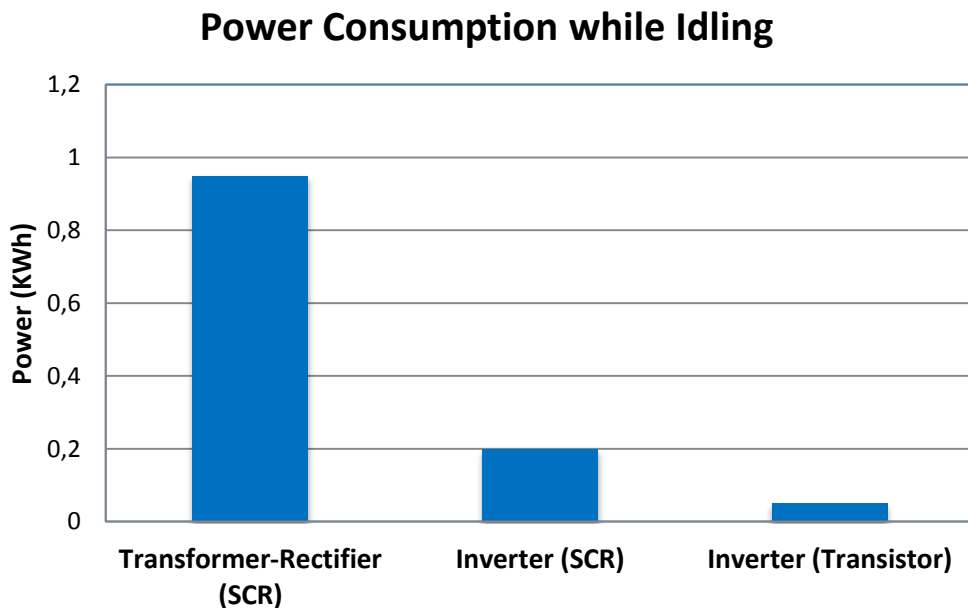

Figure 2: Idling power consumption for different welding power supply types (Bird, 1993).

Nowadays, power source designers use transistor technology for control and silicon-controlled rectifiers (SCRs) for power. The inverter power supplies using transistor technology have very good energy conversion rates and provide faster response times and higher pulse frequencies when compared to the old transformer/rectifier power supplies. Fine-tuned optimization of the welding process have been made possible with high performance power electronic devices that can produce manipulated pulse waveforms for controlling the weld characteristics. For example, in the early days, the arc manipulations and control were limited by the shortcomings of the 50/60 Hz technology. However with high-speed switching circuits and computations today, the welding machine could predict the minor disturbances in the arc and out-react them at very high speeds. The power sources can deliver power to the arc in any form we deem appropriate. These advancements that improves, the efficiency of the welding systems have been made possible because of better understanding of the weld-arc phenomenon and the innovations in electronic industries. (Bird, 1993; Wu, et al., 2005; Purslow, 2012)

Table 1 shows the comparison of the conventional and modern power source designs (Praveen, et al., 2005). With the help of these technologies the Inverter-based power sources operate at higher frequencies than traditional power sources. Working at higher frequencies enable smaller, more efficient magnetic components to be used which in-turn requires less electrical power and reduce overall energy use (Larry, 2012; The Lincoln Electric Company, 2014). Table 2 shows the mean efficiencies of the power source systems marketed among EWA members 2009-2011 (Karsten, et al., 2014).

Table 1: Comparison of conventional and modern power source designs (Praveen, et al., 2005).

Power Sources	Traditional	Inverter
Power Consumption	High	Low
Electrical Efficiency	Poor	Good
Size	Large	Compact
Weight	More	Less
Frequency of Operations	Low	High
Running Cost	High	Low
Cost of Production	High	Low
Labor Cost	High	Low
Material Cost	High	Low
Number of Tapings in Transformer	More	None
Design	Simpler	Complex
Control of metal transfer mode	Poor	Better
Arc Stability	Low	High

Table 2: Efficiency of arc welding machines (Karsten, et al., 2014).

Technology	Inverter single phase	Inverter three phase	Thyristor or Chopper three phase	Transformer single phase	Transformer three phase	Rotating type
Mean efficiency (%)	78	83	73	68	73	45

Advanced digital control system used in the newer power sources incorporate digital signal processors to ensure excellent performance. The degree of controlling the arc characteristics have increased considerably with help of precise monitoring electronics that monitor the arc in real time and signals pulses simultaneously to correct the irregularities in the arc. These information's that are sensed from the arc are sent as feedback for automatic manipulation of the weld parameters with the help of algorithms. Digitalization of the process has enabled attaining higher feedback response rate. (Himmelbauer, 2003) The fact that these electronic systems are very intelligent in acquiring and sending correct signals at the correct time in order to make real-time corrections to the output, shows the level of development in the electronic industries.

Waveforms, which are responses of welding power source, are initiated by the software to counter the actions of welding arc and they can be manipulated to suit different welding conditions. For example, in case of Pulsed-Gas Metal arc welding (P-GMAW), the area under the waveform determines the amount of energy transmitted by a single droplet to the workpiece. In-order to achieve better penetration, two distinct series of welding pulses and pulsing wire-feed rate can be used as shown in the Figure 3. In Figure 3(a), hot and cold series of pulses are maintained at a particular frequency to achieve better penetration. The cold pulses regulates the arc length, preheats both the electrode wire and the material surface and produce a weld ripple each time it is fired. The hot pulse provides better control over weld pool and penetration. Ripples on the weld bead are generated due to the pulsing of wire-feed rate and this produces the acceleration and deceleration phases. During acceleration phase, arc energy grows and achieves better weld penetration. In deceleration phase, arc energy reduces and stabilizes weld pool. Therefore improvement in weld quality can be achieved with reduced re-work and consumption of energy. (Praveen, et al., 2005)

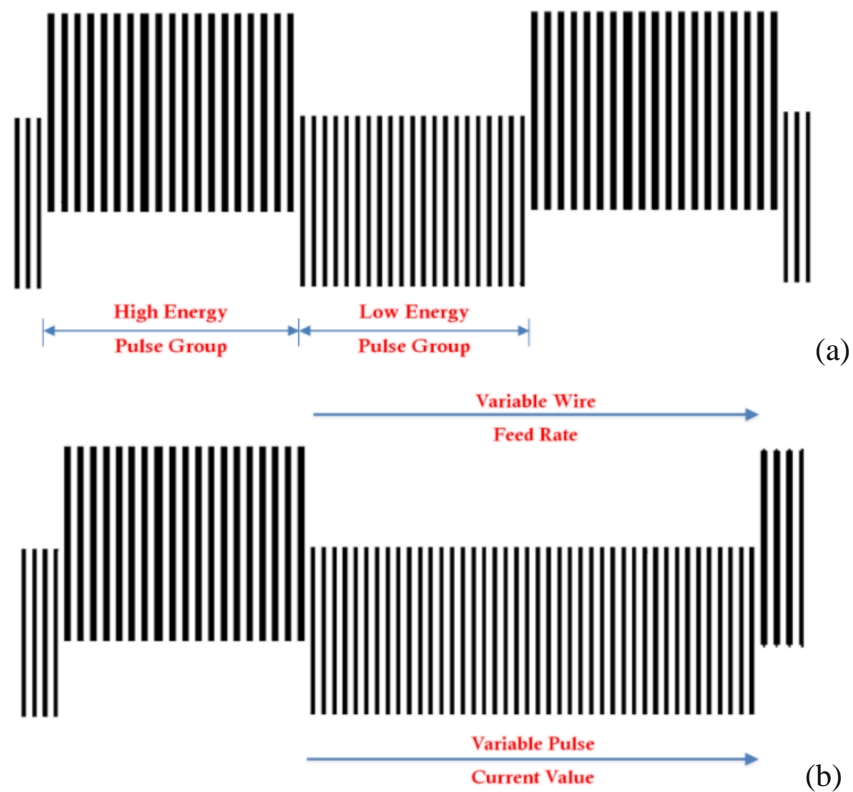

Figure 3: Different pulse waveforms of P-GMAW to achieve better penetration (Praveen, et al., 2005).

Similarly another example which shows the success in implementation of the inverter technology, is the Alternating Current - Gas Metal Arc Welding (AC-GMAW). In the early years of its introduction, the technology used in AC-GTAW was very costly, complex and even problematic. Transformer technology was used for generating the arc from a 60Hz incoming sine wave power. A bulky system including a heavy transformer to supply power and an equally heavy magnetic amplifier to control output, were the major drawbacks with this system. During the reversing of current flow, very high frequency was required to properly re-ignite the arc and to ensure proper cleaning action of aluminium surface. The system design was always a less-than-perfect process because of frequent distortion in the sine wave caused by the characteristic of the magnetic amplifier. (Robert & Jeff, 2013)

However the square wave era (late 1970s), saw the introduction of fast switching circuits that solved most problems related to imbalances in arc and rectification issues. Still the system was bulky and less efficient. However today, boom in the electronic industry and advancement in tungsten material have made inverter systems for AC GTAW applications more affordable, accessible and satisfy wide range of applications. Modern inverter-based welding systems change the rules of conventional AC-GTAW, providing better manipulation of the arc characteristics, longer electrode life and more programmability. Lower cost of these systems signifies the availability of a high-tech welding solution within the reach of a broader range of welders. (Robert & Jeff, 2013) *Table 3* shows the achievements of inverter technology (Robert & Jeff, 2013).

Table 3: Transformation of AC-GTAW with evolution of power source technology (Robert & Jeff, 2013).

Achievements with Inverter technology	Impact of these achievements
Better Frequency and Balance	Better control of polarity balance was achieved with square wave technology when compared to sine wave technology. However this system allowed less time on the DCEP side of the cycle i.e. 75% direct current electrode negative (DCEN) and 25% direct current electrode positive (DCEP) which translates to reduced overall heating of tungsten. Advent of inverter era promoted welding frequencies up to 200kHz. Increase in welding frequency reciprocates greater control of AC waveform, more concentrated arc column and increased pulsing capabilities. Increased balance control with balance adjustable up to 90% DCEN and 10% DCEP.
Energy saving	Inverter systems are highly energy efficient therefore save significant amount of energy and operating costs i.e. typically inverters use only half of the input amperage of older systems.
Tungsten Selection	Without replacing the tungsten electrode, switching back and forth from AC to DC was made possible with inverter technology.
Three-phase power supplies	Inverters systems can run on three-phase power supplies, whereas earlier AC-GTAW systems were limited to single phase supplies.
Increased Portability	Smaller transformer system used on an inverter based systems reduces overall weight and size of the machine, promoting system's portability. Therefore easily transportable for field work.
Low investment costs	Dramatic improvement in materials technology and manufacturing technology have translated into low cost high-end electronics.

2.1.1 Characteristics of smart power source systems

Table 4 shows the improved characteristics required by a conventional power source system to be upgraded to a smart power source system.

Table 4: Characteristics of a smart power source system.

<p>Ability to stabilize erratic power supplies</p>	<p>In many countries the problems due to under-dimensioned and fluctuating power supplies and especially the problems due to on-site generator needs to be addressed. The smart power source systems should be able to guarantee complete protection for internal electronics, thereby making the welding process independent against such power supply conditions.</p>
<p>Self-Adapting ability to input power sources</p>	<p>The smart power source systems should be able to avoid human intervention at all stages. They should possess the ability to automatically adapt to three phase main supply voltage. They should be able to dimension the main supply for a lower current draw or increase the number of usable machines for the same power supply.</p>
<p>Adhering to International Standards</p>	<p>Harmonic disturbances caused by conventional machines due to input pulsed currents, could lead to large current draws when these disturbances are transmitted back to the mains. International Standards including the EN 61000-3-12 have been introduced to limit the harmonic current disturbances in the fabrication and manufacturing industries.</p>
<p>Improved overall system Reliability</p>	<p>Smart power source systems should be able to reduce the stress on circuits and components by fetching lower current i.e. having a unity power factor. This also avoids the possibility of exceeding the maximum permitted load. Smart power systems should be capable of completely eliminating the reactive power source consumption with single phase power supplies and should be able to dramatically reducing the same with the three phase power supplies. Hence achieving a durable and reliable system.</p>

2.1.2 Eco-Welding design

Welding has several well established effective standards in place, however only limited number of relevant information for the welding-related environmental considerations are available:

- EN 14717:2005: Welding and allied processes—environmental check list (very generic guidance only on proper operation of the equipment)
- IEC 60974–1 ed4.0: Arc welding equipment—Part 1: welding power sources (annex M: welding power source efficiency)

Efforts by the safety regulators and governments have brought positive impact on the introduction of smart welding machines in various manufacturing companies. The European Commission (EC) developed eco-design requirement for wide range of product categories under the framework directive on Eco-design of Energy related Products (Erp; 2009/125/EC).

2.2 Developments in Gas Metal Arc Welding (GMAW)

GMAW is one of the most widely used welding methods in the world. GMAW was initially developed as a high deposition, high welding rate process facilitated by continuous wire feed and high welding currents (Shi, et al., 2014). The process can be easily automated and also supports integration of robotics for large scale production centres (Cary & Helzer, 2005). It has high flexibility, which allows the welding of a great variety of materials and thickness (Pires, 1996). Ever since the introduction of GMAW systems, researchers have focused on improving its performance which has considerably widened the applicability of the process and has also increased its efficiency.

Figure 4 represents the setup of the GMAW process equipment. GMAW is an electric arc welding process, where an electrode in the form of a wire is melted by the heat of the arc formed between the electrode wire and the workpiece, is consumed by the progressing weld pool. In GMAW, the arc and transfer phenomenon is highly dependent upon the variation in current and voltage from the power source (Cary & Helzer, 2005). Despite its wide application, the GMAW process has some serious limitations such as the susceptibility to porosity and fusion defects. Due to the intense current levels, GMAW produces significant levels of fumes and nitrogen oxides. When ultraviolet light from the welding arc interacts

with the surrounding air, nitrogen dioxide and nitric oxides are produced. This process also has limitations regarding the control of metal transfer. (Pires, 1996; Cary & Helzer, 2005)

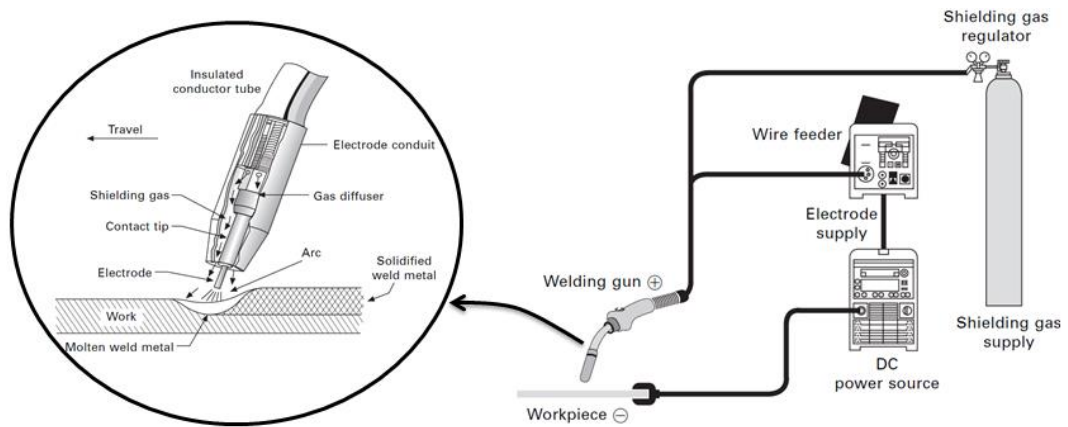

Figure 4: GMAW process equipment. Modified from (Stewart & Lewis, 2013).

In recent years, GMAW has significantly benefited from the new technological advances in the electronic industries. With the help of today's technological advancement in inverter technology, accurate manipulation of the voltage and current has resulted in better control of the arc and the transfer of weld metal. The advanced feedback control unit (as shown in Figure 5) influences the welding parameters throughout the process to secure a good welding quality. The production efficiency of GMAW and the welding quality have tremendously improved with several modifications to the welding process; the application scope of GMAW has been appreciably broadened with the help of intense research work on this field. (Shi, et al., 2014)

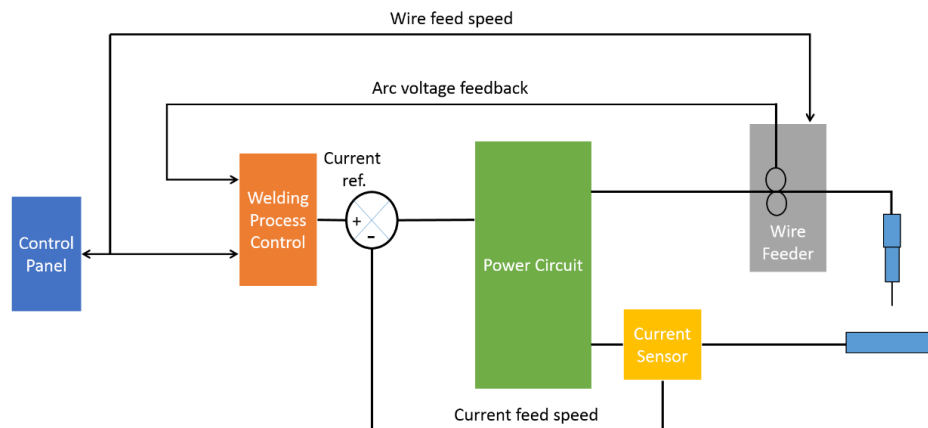

Figure 5: GMAW process control system with feedback control of welding voltage and current (ESAB and AGA, 1999).

New welding techniques have been developed to enhance GMAW process with faster deposition rate. New variants of GMAW have demonstrated their ability to successfully weld thin sheet plates, dissimilar joint and metal sensitive to heat input and also they have achieved significant reduction in heat input, sparks and smoke yet they are able to work within the conventional voltage ranges and lower currents.

The manner in which the liquid metal transfers from the electrode to the weld pool is most important in determining the welding process stability and weld quality. The Laser-enhanced GMAW is an innovative process developed at the University of Kentucky. A lower-power laser is projected onto the droplet and free flight metal transfer is achieved with help of recoil pressure of the laser on the droplet. In this process the necessary dependence of metal transfer mode on the current, as in conventional GMAW, is avoided thereby providing more flexibility in choosing the right amount of current for the required weld penetration and weld pool. (Huang & Zhang, 2010; Huang & Zhang, 2011(a); Huang & Zhang, 2011(b)). Figure 6 shows the basic principle, setup and typical metal transfer in laser enhanced GMAW.

Similarly another method where the ultrasonic wave is used as an auxiliary force to detach the droplet from GMAW process is proposed – Ultrasonic Wave enhanced GMAW. With Ultrasonic wave enhanced GMAW, higher metal transfer frequency can be achieved than conventional GMAW. However the decrease in transition current of this process is very less than the laser enhanced GMAW. Figure 7 shows the basic principle and typical metal transfer in ultrasonic wave enhanced GMAW.

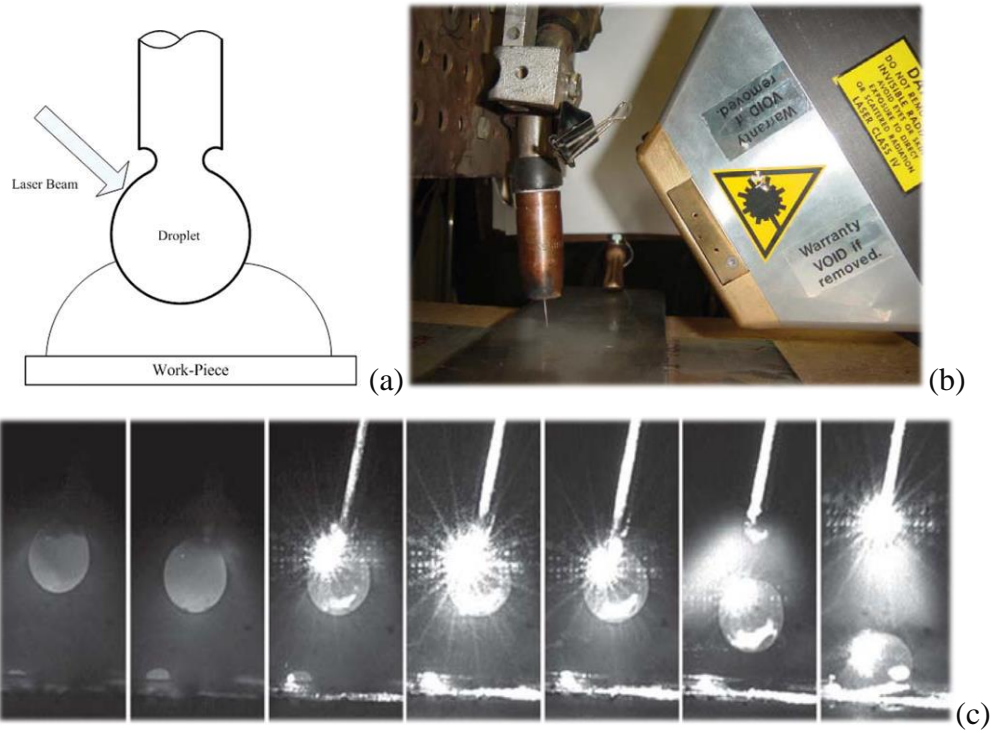

Figure 6: Basic principle (a), setup (b) and typical metal transfer (c) in laser enhanced GMAW (Huang & Zhang, 2010; Huang, et al., 2012).

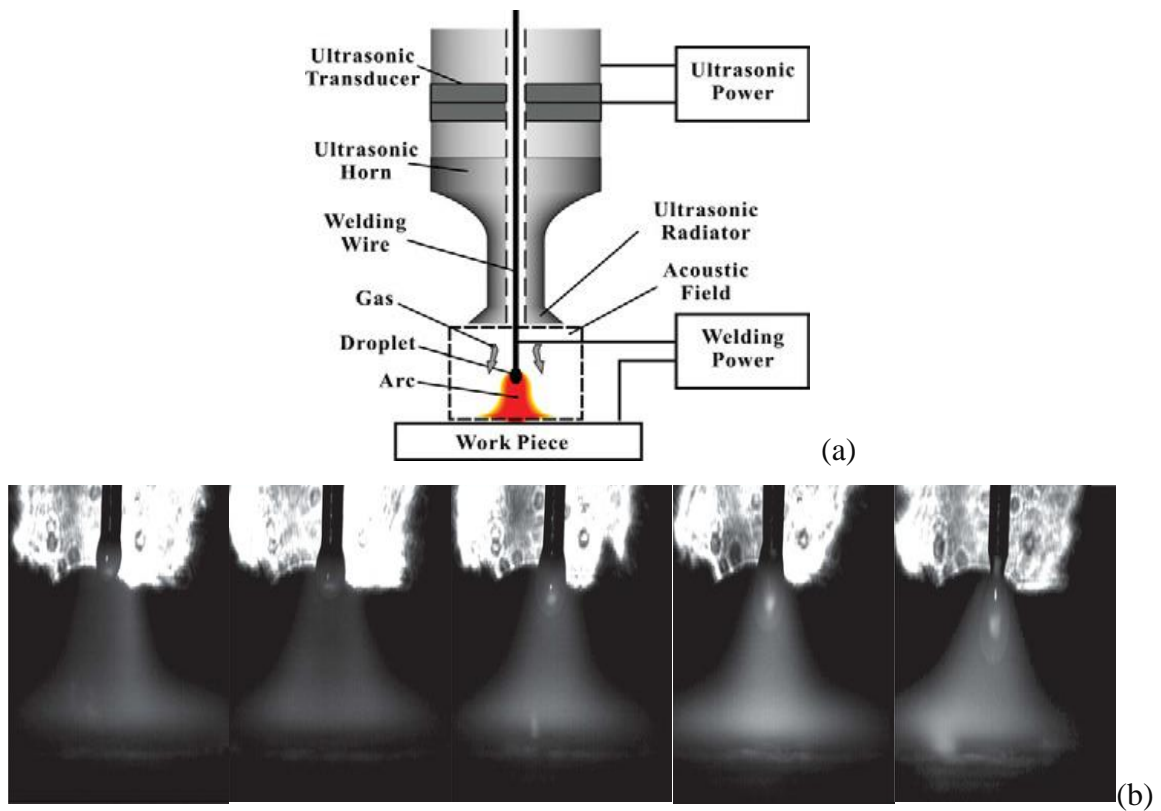

Figure 7: Basic principle (a) and typical metal transfer (b) in ultrasonic wave enhanced GMAW (Fan, et al., 2012).

The one-sided welding with back formation is an efficient welding technology. In one-side welding technique, the joint is accessed from one side yet the welds are produced on both sides of the joint with acceptable properties, geometry and integrity. The backing arrangement helps in shaping the molten root reinforcement and supporting. The technique finds application in fabrication of pressure vessels, bridges and large steel structures. One-sided welding eliminates the requirement of careful turning of panels thereby improving production efficiency, reducing labour intensive work. Figure 8 shows the comparison between conventional MAG and the one-sided MAG method. (Kimoto & Motomatsu, 2007)

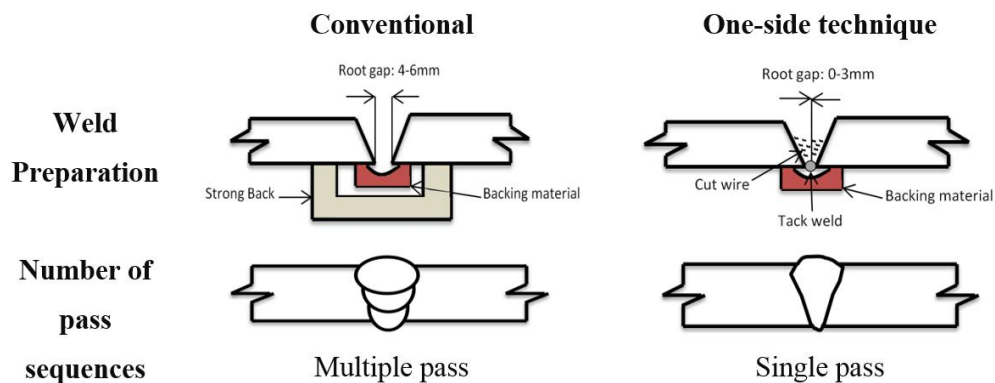

Figure 8: Comparison between conventional arc process and the one-sided arc technique (Kimoto & Motomatsu, 2007).

2.2.1 Pulsed-Gas Metal Arc Welding (P-GMAW)

P-GMAW process is a recognized and accepted technology for efficient welding. P-GMAW which is a modified spray transfer process provides the best of both short-circuiting and spray transfer, by using a low base current to maintain the arc and a high peak current to melt the electrode wire and detach the droplet. The constant research and development work on P-GMAW process has resulted in better power sources. The continuous improvement in control technology has led to the evolution from thyristor to IGBT to single-chip-microcomputer control. (Palani & Murugan, 2006; Hang, et al., 2014)

The continuous improvement in control technology has led to the evolution from thyristor to IGBT to single-chip-microcomputer control. The P-GMAW process works by forming one droplet of molten metal at the end of the electrode per pulse. Then, just the right amount of current is added to push the droplet across the arc and into the puddle by means of powerful electromagnetic force. The magnitude and the duration of the pulse needs to be

modulated with help of reliable feedback signal in order to control the magnetic force. Feedback signal can be achieved by monitoring the excited droplet oscillations. Unlike conventional GMAW, where current is represented by a straight line, P-GMAW drops the current at times when extra power is not needed, therefore cooling off the process. It is this “cooling off” period that allows P-GMAW to weld better on thin materials, control distortion and run at lower wire feed speeds. The P-GMAW provides additional control by maintaining the arc at a low background level current waveform, which is superimposed by a pulse current to detach the metal. (Needham, 1962; Shimada & Ukai, 1981; Hang, et al., 2014)

Compared with P-GMAW, double-pulsed GMAW (DP-GMAW) has wider adjusting range of parameters, so that the wire feed rate is easy to control (Liu, et al., 2013). The DP-GMAW can be considered a means of increasing productivity without quality drops. A good weld joint with regular ripple surface are obtained with this high production efficiency welding technology. The DP-GMAW technique is a variation of the pulsed GMAW technique, where the pulsing current that controls the metal transfer is overlapped by a thermal pulsation, improving the pool control. The main feature of the DP-GMAW is that the welding process is influenced by high-frequency pulse (HFP) and thermal pulse simultaneously. The role of a low frequency current pulsation (thermal pulsation) is to control the weld pool. As shown in the Figure 9 welding current waveform changes from a group of high frequency pulses (large average current) to a group of low-energy pulses (small average current). The thermal pulse frequency can be used to manipulate the arc plasma force and heat input, thereby forming the weld bead ripple and expanding the range of weld joint clearance. The DP-GMAW technique, in spite of having theoretically higher potential for porosity generation, does not increase the porosity susceptibility in aluminum welding, when compared with the P-GMAW technique. Tong and Tomoyuki (2001) showed that this welding process provided beautiful scaly bead, improved gap-bridging ability for lap joint, restrained blowholes for formation, refined grain size, and decreased crack sensibility. (Silva & Scotti, 2006; Liu, et al., 2013)

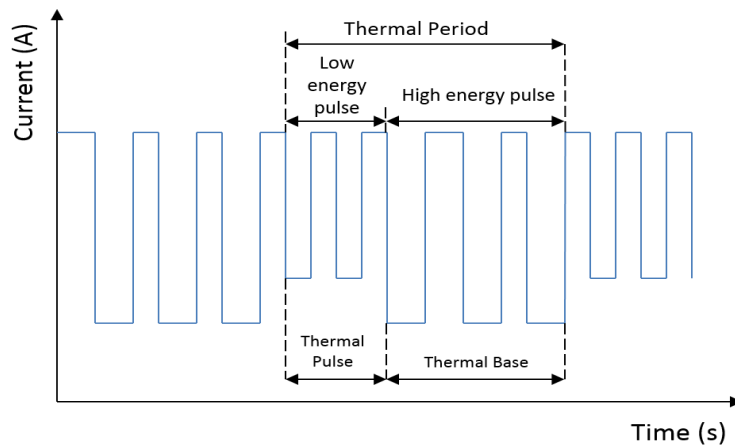

Figure 9: Current waveform of double-pulsed GMAW (Celina & Américo, 2006).

2.2.2 Cold Metal Transfer (CMT)

The capability of producing low heat input welds with low dilution of base alloys, limited structural distortion and very low residual stresses, makes the CMT one of the promising choice for joining of dissimilar alloys (Ola & Doern, 2014). To emphasize the importance of the reduced heat input, the adjective ‘cold’ has been introduced. CMT process is free from spatter and the heat input is very small since the CMT is operated in a very low current when compared with conventional fusion process (Yang, et al., 2013). In CMT welding, the substantial reduction in heat input results in a cooler weld with very little workpiece strain, being suitable for good-quality, high-precision welding (Furukawa, 2006).

CMT, developed by Fronius is similar to MIG/MAG welding process, only varies on the mechanism of droplet transfer. The droplet transfer occurs by an entirely new mechanical droplet cutting method (Furukawa, 2006). In CMT, which is a relatively new welding technology, the filler wire is intentionally retracted instantaneously after the occurrence of the short circuit resulting in a precise wire control for material transfer (Yang, et al., 2013). Feeding the wire forward after a predetermined duration of time along with the molten metal droplet results in a momentary arc collapse i.e. a short circuit happens and then material transfer occurs at a significantly low current and low voltage. Now when the electrode is retracted mechanically, for a particular duration of time, it helps in detaching the molten droplet into the weld pool. The arc reignites with the perfectly controlled retraction movement of the wire and then the cycle repeats again. (Lorenzina & Rutilib, 2009; Ola & Doern, 2014) Substantial decrease in the weld heat input, sharp decrease in the arc pressure and low temperature welding zone are some of the best advantages over the traditional

welding process (Furukawa, 2006). Figure 10 shows the area of use of the process in a voltage–current diagram. (Lorenzina & Rutilib, 2009)

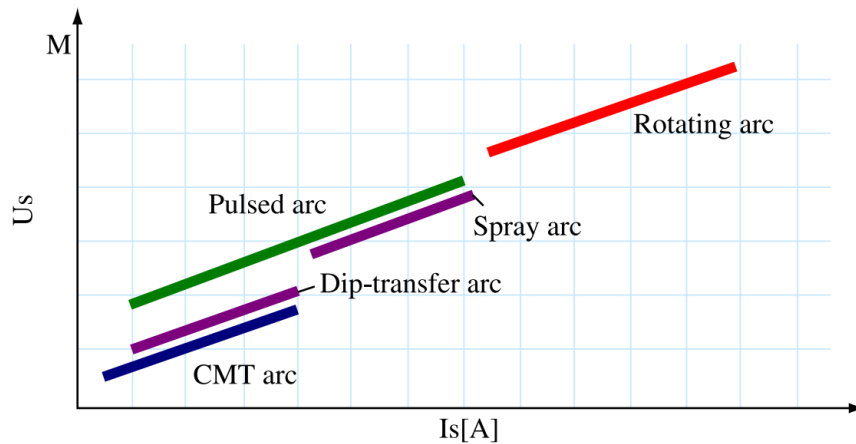

Figure 10 : Power–current diagram with CMT process area of application. (Lorenzina & Rutilib, 2009)

The CMT process turns into reality a number of difficult joining tasks welding dissimilar materials. Very small heat affected zone, very limited distortion, a good gap-bridging capability for welded joints with large gaps and improved productivity are some of the tremendous improvements with CMT process when welding thin dissimilar plates as reported by Shang et al (2012) and Cao et al (2013). Zhang et al. (2009) used CMT to weld aluminium to zinc coated steel. The CMT process is destined to encounter widespread future applications in huge range of fields, through providing solutions for welding applications previously regarded as impossible, for example welding of 0.3 mm thick ultra-thin aluminium sheets, and arc welding of steel to aluminium (Furukawa, 2006). Improved ability to compensate for high edge coupling tolerances is one of the most significant advantages of CMT. The problem encountered when welding thin thicknesses with large gaps between the edges to be joined, is represented by the relatively high heat input, so high indeed as to melt the edges before the weld bead has been formed. (Lorenzina & Rutilib, 2009) According to Ola & Doern (2014) report, components manufactured from nickel-base super alloys have extraordinary opportunity of being clad during fabrication and repair process with the help of CMT process. Their results also indicated that the shape and size of the weld beads and the extent of dilution of the weld metal with substrate were significantly influenced by the synergic CMT welding. Similarly Furukawa (2006) reported that when the weld heat input was substantially reduced and low heat input welding being performed, weld beads with a narrow width and large thickness were obtained. As the short

circuited current is maintained as low as near zero the CMT, results in a Spatter-free weld. This peculiarity of the CMT process translates into the elimination of the costly activities associated with cleaning the piece of molten metal spatter (Lorenzina & Rutilib, 2009).

2.2.3 Double Electrode Gas Metal Arc Welding (DE-GMAW)

Significant improvement in the deposition rate without increasing the heat input, or a balanced heat input and deposition rate can be obtained with DE-GMAW as desired by different applications (Zhang, et al., 2004; Li, et al., 2007). The bypass current supports the consumable DE-GMAW by increasing the deposition rate and the non-consumable DE-GMAW by reducing the heat input (Lua, et al., 2014). Therefore the challenges in conventional GMAW such as the fixed correlation of the heat input with the deposition can now be improved with DE-GMAW.

DE-GMAW is an effective welding process which uses two electrodes that are either non-consumable or consumable. Figure 11 provides the overview of the general principle of the DE-GMAW principle. The main loop shown in the diagram represents a conventional GMAW process. The bypass torch, which can either be powered by a separate power supply or from main supply, has an additional electrode to form an additional arc also called the bypass arc. In conventional GMAW and its variants, the deposition rate can be enhanced by increasing the wire current which in turn increases the base metal current as the base metal current is exactly the same as wire current. Therefore, the base metal current increases consequently, regardless of the actual need of the workpiece. The DE-GMAW stands apart from this principle by incorporating a bypass channel such that the deposition rate is no longer proportional to the heat input applied to the workpiece. The second electrode is added to bypass part of the wire current. Therefore the manipulation of the welding characteristics with DE-GMAW avoids the challenges related to fixed correlation of the heat input with the deposition. (Lua, et al., 2014) For both the consumable and non-consumable DE-GMAW, bypass current can be used to manipulate the melting speed and heat input. Without varying the heat input, melting speed can be increased (similarly without reducing the melting speed, heat input could be reduced) (Lua, et al., 2014).

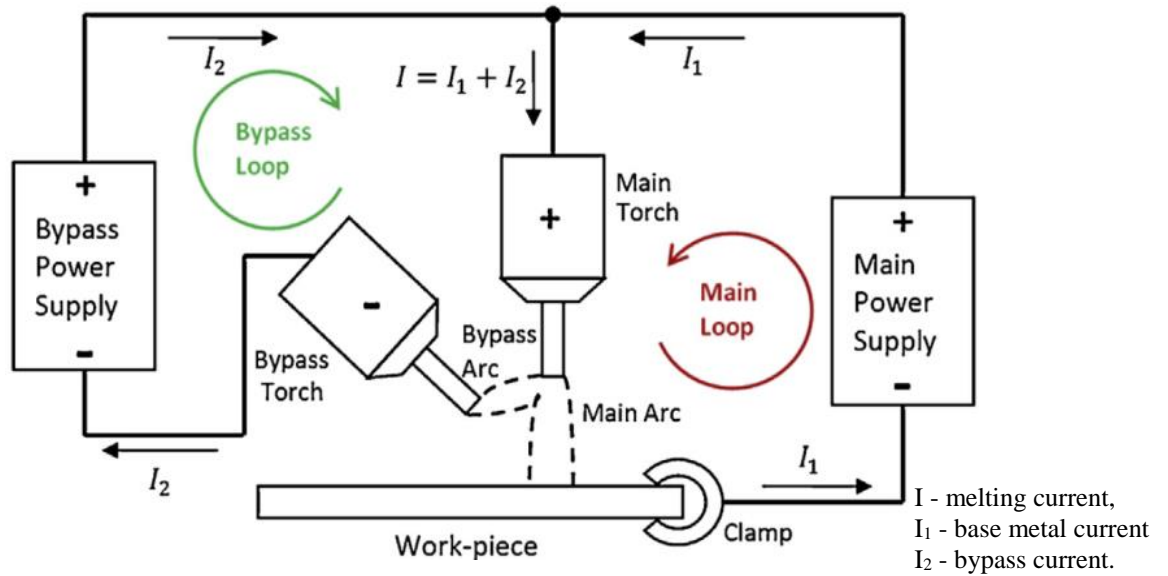

Figure 11: The basic setup of DE-GMAW process (Lua, et al., 2014).

2.2.4 Tandem-Gas Metal Arc Welding (T-GMAW)

Tandem gas metal arc welding (T-GMAW), a variation of GMAW achieves dramatic increase in welding productivity compared to conventional techniques and welding speeds up to 200 cm/min for single pass welds. The main advantage of T-GMAW is its flexibility in addition to increased weld speed, less spatter and very high deposition rates. The process has been commercialized a decade ago, however, its use for out-of-position welding is relatively new. (Ian, 2011)

Typical T-GMAW has two electrodes which are fed through a single welding gun. T-GMAW is different from DE-GMAW because of the independent adjustment control during the droplet transfer mode in T-GMAW. Typically one electrode works with the continuous arc mode and other pulsed arc mode. Improved process stability and significant increases in deposition rate and travel speed are achieved with the synergistic interactions between the two welding arcs, (Nadzam, 2003; Ueyama, et al., 2005(a)) The Most popular combination includes

- Spray + pulse: Axial spray transfer on the lead arc followed by pulsed spray transfer on the trail arc.
- Pulse + pulse: Pulsed spray transfer on both the lead and the trail arc.
- Spray + spray: Axial spray transfer on both the lead and the trail arc.

The energy intensive Spray + Spray combination is best suited for special heavy plate deep welding and the Pulse + Pulse combination is best suited for high speed sheet welding.

2.2.5 Alternating Current - Gas Metal Arc Welding (AC-GMAW)

The AC-GMAW combines the advantage of arc stability from the DCEP region with that of the high melting rate from the DCEN region to secure good weld quality (Harada, et al., 1999). The cleaning action of AC helps to reduce the black soot-like oxide particles on the surface of the aluminium alloys. The AC-GMAW is well known for its improved distortion control, reduced heat input, higher melting rate of welding wire at a given power level and reduced dilution. The process can deposit more filler into the gap with minimal amount of heat during the EN portion, as electrons flow melts the wire more than it does the base metal. (Larry, 2012; Nabeel & Hyun, 2014)

Overcoming the problem of switching from electrode positive (EP) to electrode negative (EN) was a big challenge during the early days. This is because, as the AC power transitions through 0, the arc plasma collapses and needs to be re-established. Similarly in the EN portion of the cycle achieving the droplet formation and transfer is difficult. However with introduction of high speed switching circuits and inverter technology, these problems were solved. In the EN region, the droplet develops at a faster pace due to high melting rate of the process, however in the EP region, arc is maintained and gets prepared for the drop detachment that occurs in the high EP region. During the shift in the modes from DCEP to DCEN, the arc covered angle and the direction of current flow varies with each pulse. The power supplies were able to take advantage of the direct current electrode positive (DCEP) and negative (DCEN) regions to overcome these problems and thus resulted in a process called Alternating Current GMAW. In this process the DCEP regions arc stability is combined with the DCEN regions high melting rate to avoid burn through. (Larry, 2012; Nabeel & Hyun, 2014)

With the main aim of overcoming the negative effects of welding thin sheets with P-GMAW, Jaskulski et al (2010) demonstrated the capabilities of AC-GMAW power supplies which were developed by implementing a new synergic program in their inverter power source to achieve optimal control over the AC-GMAW process for both steel and aluminium alloys. Figure 12 shows the comparison of the current waveforms of P-GMAW with AC-GMAW

in steel and aluminium. The current pulse is separated as the EN base region and EN peak region, where the EN base region helps in maintaining the arc and the EN peak region helps in increasing the wire melting rate. In aluminium welding, adopting a simpler classical waveform helped in achieving a stable arc up to an EN ratio of 30%. Kah et al. (2012) demonstrated the application of an AC-GMAW pulse having an EN ratio greater than 30% in welding of the steels. Ueyama et al (2005) suggested that a low heat input is supplied to the workpiece yet a higher melting rate is achieved with the help of DCEN polarity in the pulse, thereby resulting in shallower penetration with gap bridging ability. Therefore, AC GMAW process can successfully minimize the amount of expensive material applied and shortens the time to deposit the material. This is made possible by the enhanced control of dilution and increased deposition rate of the process (Larry, 2012).

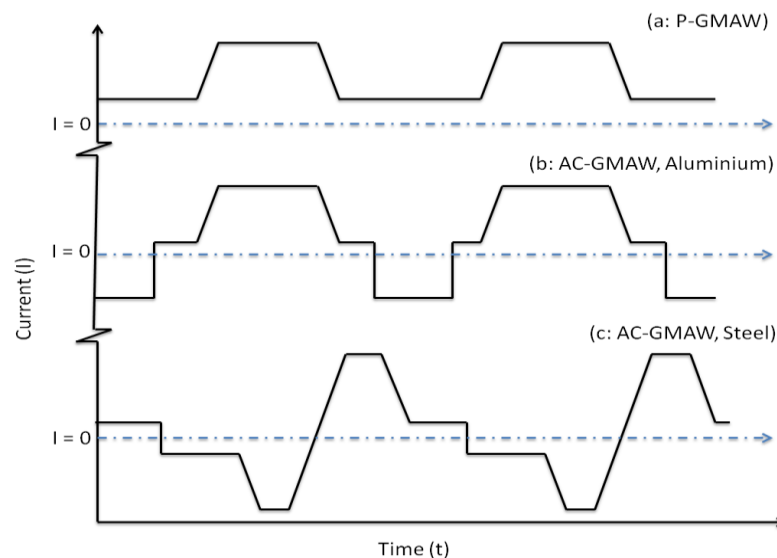

Figure 12: Comparison of current waveforms of P-GMAW with AC-GMAW (Nabeel & Hyun, 2014).

2.3 Developments in Friction Stir Welding (FSW)

Friction stir welding has been considered as the most significant development in metal joining of the past decade. It is regarded as a green technology because of its energy efficiency, environment friendliness and versatility. FSW, a solid-state, hot-shear joining process, was developed by The Welding Institute (TWI) in 1991 (Thomas, et al., 1991). Use of FSW has gained a prominent role in the production of high-integrated solid-phase welds in 2000, 5000, 6000, 7000, Al-Li series aluminium alloys and aluminium matrix composites.

The FSW process progresses sequentially through the pre-heat, initial deformation, extrusion, forging and cool-down metallurgical phases. Figure 13 shows the schematics of friction stir welding. The welding process begins when the frictional heat developed between the shoulder and the surface of the welded material softens the material, resulting in severe plastic deformation of the material. The material is transported from the front of the tool to the trailing edge, where it is forged into a joint. Consequently, the friction stir welding process is both a deformation and a thermal process occurring in a solid state; it utilises the frictional heat and the deformation heat source for bonding the metal to form a uniform welded joint - a vital requirement of next-generation space hardware. In FSW, several thermo-dynamical process interactions occur simultaneously, including the varied rates of heating and cooling and plastic deformation, as well as the physical flow of the processed material around the tool. Throughout the thermal history of a friction stir weld, no large-scale liquid state exists. (Schneider, et al., 2006; Nandan, et al., 2008; Grujicic, et al., 2010; Dunbar, 2014)

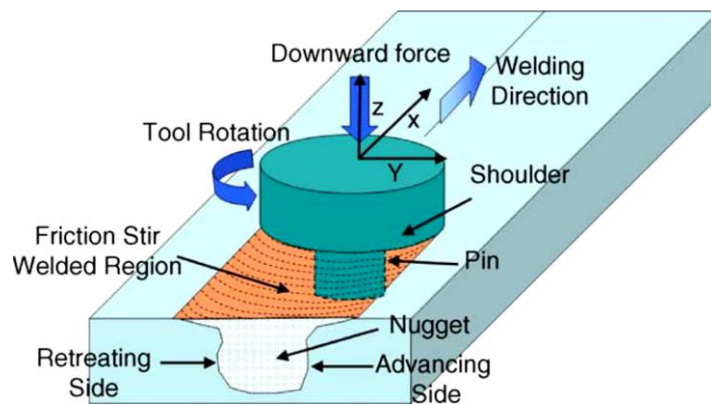

Figure 13: Schematics of the friction stir welding process (Mishra & Ma, 2005).

Aerospace industries benefit from the innovative manufacturing developments, such as friction stir welding. FSW is the mainly used joining method for structural components of the Atlas V, Delta IV, and Falcon IX rockets as well as the Orion Crew Exploration Vehicle. Industries have started researching the applications of the FSW in new materials that are difficult to weld using conventional fusion techniques. (Prater, 2014) The stronger joints achieved with the FSW are used to join the tank and structural segments with fewer defects than possible using other arc welding. FSW has benefitted the aerospace industries tremendously as earlier joining methods were in-efficient and unreliable. For example FSW

will perform an integral part in development of the Space Launch System's core stage, which will be powered by RS-25 engines (space shuttle main engines), at NASA (2013). Many innovations in FSW have been made in NASA with its continuous research. For example in the original FSW, a keyhole or a small opening is formed when withdrawing the rotating pin which is a potential weakness in the weld therefore requiring an extra step to fill the hole during manufacturing. So engineers at NASA's Marshall Space Flight Centre developed an innovative pin tool that retracts automatically when a weld is complete and prevents a keyhole. Welds become stronger and eliminates the need for patching. The retracting pin also allows materials of different thicknesses and types to be joined together, increasing the manufacturing possibilities. (Boen, 2009) One of the main issues in fusion welding is the material composition compatibility; however no filler material is used in FSW hence this problem is avoided here (Tolga Dursun & Costas Soutis, 2013). *Table 5* provides the advantages with using FSW over the conventional fusion process.

Table 5: Benefits of the FSW Process (Nandan, et al., 2008).

Metallurgical Benefits	Environmental benefits	Energy Benefits
<ol style="list-style-type: none"> 1. Solid Phase Process 2. No loss of alloying elements. 3. Low distortion 4. Good dimensional stability and repeatability 5. Excellent mechanical properties in the joint area. 6. Fine recrystallized microstructure. 7. Absence of solidification cracking. 8. Replaces multiple parts joined by fasteners. 	<ol style="list-style-type: none"> 1. No shielding gas required for materials with low melting temperature. 2. Eliminates solvents required for degreasing. 3. Minimal surface cleaning required. 4. Eliminates grinding wastes. 5. Consumable materials saving. 6. No harmful emissions. 	<ol style="list-style-type: none"> 1. Improved materials use (e.g. joining different thickness) allows reduction in weight. 2. Decreased fuel consumption in lightweight aircraft, automotive, and ship applications. 3. Only 2.5% of the energy needed for a laser weld.

In order to enhance the strength, rapid cooling of the friction stir weld has been experimented and proved to be successful. In the stir zone, the grain size decreased and the number fraction of the high angle boundaries increased with the increasing number of FSW cycles. The texture analysis suggested that the post-annealing effect, which frequently occurred after the FSW process, was remarkably restricted by the liquid CO₂ cooling, which accelerated the refinement of the microstructure. As a result, a joint with an ultrafine grained structure and an excellent strength and matching ductility can be achieved by rapid cooling of multi-pass FSW process. Although the substructure significantly enhanced the strength of the stir zone, the ductility was reduced. (Xu, et al., 2015)

Laser assisted friction stir welding is a combination of the conventional FSW machine and a Nd:YAG laser system. This systems minimizes the need for strong clamping fixtures, force required for plasticizing the material, wear rate of the tool pin. In this process, the laser power is used to preheat the localised area in the work piece before the penetration of rotating tool. The high temperature softens the workpiece thereby enabling quality joints without strong clamping forces. Added advantage includes high weld rates and reduced tool wear rate. (Kohn, 2001)

2.3.1 Friction Stir Spot Welding (FSSW)

FSSW is a green and sustainable variant of linear FSW, where no transverse movement occurs but uses a central pin, a surrounding sleeve, and an external plunger with independent movement at different speeds to fill the keyhole which is a major problem with conventional FSW. As shown in the Figure 14, the reciprocating parts carefully control the relative motion and applied pressure of the pin, sleeve, and plunger to refill the pin hole. This process offers greater alloy joining flexibility, significantly reduces energy consumption, lesser peripheral equipment, lower operational cost and lower weld distortion than Resistance Spot Welding (RSW) and has therefore, been considered as a potential alternative for RSW and clinching, to fasten two metallic workpieces. Significant reduction in capital cost of up to 50% can be realized when compared to resistance spot welding. (Nigel & Kevin, 2012)

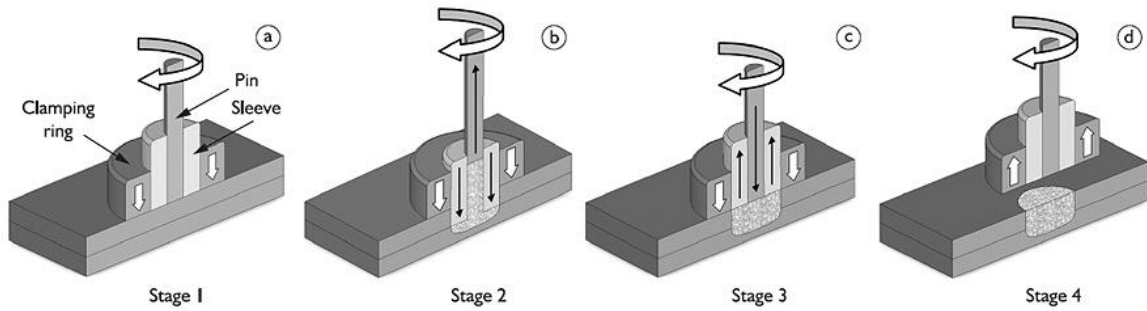

Figure 14: Schematic representation of friction stir spot welding (Koen, 2015).

2.3.2 Reverse dual-rotation friction stir welding (RDR-FSW)

RDR-FSW supports very low welding loads and improved weld quality. The total torque exerted on the workpiece by the tool is reduced. The overheating problems are significantly reduced by this process. (RDR-FSW) is a variant of conventional friction stir welding (FSW) process. The peculiarity about this process is that the tool pin and the assisted shoulder are independent and so they can rotate reversely and independently during welding process. This promotes improved weld quality and low welding loads, by adjusting the rotation speeds of the tool pin and the assisted shoulder independently. In RDR-FSW, the reversely rotating assisted shoulder partly offsets the welding torque exerted on the workpiece by the tool pin. Therefore the total torque exerted on the workpiece by the tool is reduced. This simplifies the clamping equipment thereby lowering the size and the mass of the welding equipments. The problem of overheating or incipient melting can be avoided by optimizing rotational speeds of both the tool pin and assisted shoulder as the tool pin can rotate in a relatively high speed while the assisted shoulder can rotate in an appropriate matching speed. The effect of reverse rotation of tool pin and assisted shoulder is very limited on heat generation, however, homogenous temperature distribution and lower torque on workpiece is attained with the corresponding material flow pattern and the distribution of heat generation rate. (Shi, et al., 2015)

2.4 Developments in Hybrid Welding Process

The basic concept behind the innovative hybrid process is to combine the benefits of two or more processes to achieve an excellent weld (Ribic, et al., 2009). The Hybrid Laser Arc Welding (HLAW) couples the laser beam and the GMA, GTA, or plasma arc welding process in a common weld pool. As described in Figure 15 laser beam welding vaporizes

the metal intensely which in turn improves the arc stability and the droplet transfer of GMAW. Narrower weld seams, higher tensile strength, deeper penetration, lower thermal input and higher welding speed could be obtained with HLAW when compared to GMAW process. Their high efficiency, high beam quality, and low operational expense make them particularly suitable for heavy wall thickness welding. In addition, much higher travel speed for successful root pass welding and very high productivity can be achieved by optimizing the P-GMAW + laser process. The combined P-GMAW and laser process is one of the current development directions of the HLAW technology. (Qin, et al., 2007; Ribic, et al., 2009; Cao, et al., 2011; Ian, 2011)

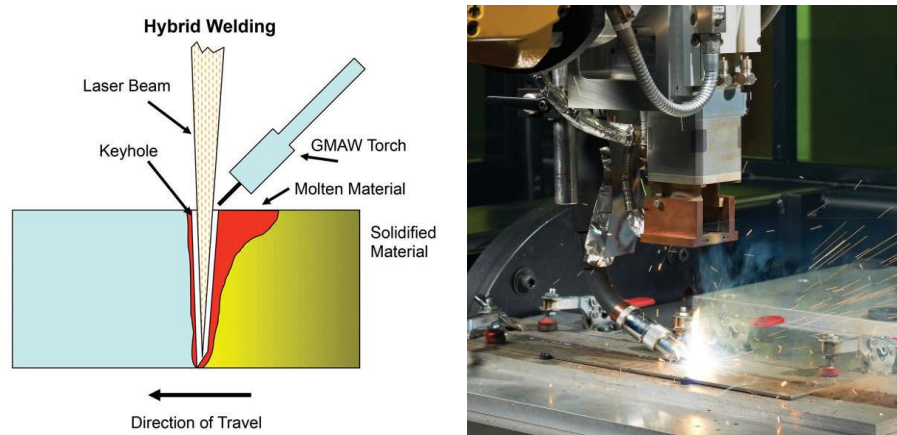

Figure 15: Schematics of the hybrid laser arc welding process (Paul, 2013).

Although the hybrid laser-GMAW system was introduced almost 20 years ago, the technology never gain much appreciation due to high cost and limitations of CO₂ laser (greater than 5kW). However, innovation in the laser delivery system of high power solid-state lasers (Yb-disk and Yb-fibre) changed the whole picture. High-power Yb-fibre lasers with 25% efficiency allow a 10kW laser to be built to the size of a refrigerator. This significantly improves the portability of the welding unit and broadens the application of this technology. Dramatic fall in ownership cost of these systems fuelled their growth in the commercial industries. High-strength, high-integrity pipelines such as X80 and X100 pipes can now be precise welded with high quality using the innovative hybrid welding system. The laser beam welding with very high penetration capability combined with the good gap bridgeable characteristic of GMAW results in a weld with very high speeds, good penetration and less sensitive to gap variations. However high capital cost, accurate alignment of beam and arc and the necessary automation of this process are the

disadvantages to be considered before process selection. (Cao, et al., 2011; Ian, 2011; Paul, 2013) Experiments conducted by Zhang et al (2014) suggested that a more stable welding process can be obtained with the laser leading mode. This is because the plasma's cross-sectional area is increased and expanded with the laser leading mode and so this reduces the electrical resistance of the arc and hence it also reduces the required voltage for the same current.

2.5 Developments in Gas Tungsten Arc Welding (GTAW)

GTAW is a widely used process for metal joining. In GTAW, the arc established between the non-consumable tungsten electrode and workpiece usually produces high-quality and spatter-free welds with precise control over the stable arc (Cary & Helzer, 2005).

2.5.1 Arcing-wire GTAW

In-order to attain desirable welds, filler metals are required during GTAW welding. When the filler metal is directly used without any pre-treatment, the process is termed as cold-wire GTAW. Similarly if the filler metal is pre-heated by means of AC before adding to the GTA welding, then it can be termed as hot-wire GTAW. Very high deposition could be realized with hot-wire GTAW, however with more complicated and costly additional setup than required for cold-wire GTAW. Unfortunately complete melting of filler wire occurs by consuming part of the heat generated from weld pool, thereby requiring larger weld pool for high deposition rate. Since the deposition rate is dependent on the supplied energy, the productivity is reduced,. In-order to solve this problem, a side arc is established in the gas tungsten arc between the wire and tungsten to melt the wire, thereby eliminating dependence of deposition rate on weld pool mass. The potential difference between the wire and tungsten can be established using a second power supply. So the primary difference between arcing wire technique and the hot-wire technique is the melting mechanism for the filler metal. The wire can thus be melted at same rate of a GMAW process yet maintaining the ability to freely deliver the current and current waveform as per the requirements from the application. (Cary & Helzer, 2005; Chen, et al., 2012)

2.5.2 Pulsed Gas Tungsten Arc Welding (P-GTAW)

The P-GTAW is a very effective variant of GTAW which offers lower heat input, narrower heat affected zone, finer grain size, less residual stresses and distortion, improved

mechanical properties, enhanced arc stability to avoid weld cracks and reduce porosity when compared to conventional GTAW. The most important advantage of pulsed current GTAW is its lower heat input which results in diminishing of distortion and warpage in thin work pieces. In the pulsed current mode, the welding current rapidly alternates between the higher current state (pulse current) and the lower current level (background current). During high current state, the weld area is heated and fusion occurs, upon dropping to the background current, the weld area is allowed to cool and solidify. The heat energy to melt the base metal is provided mainly by the peak current, while the background current is set at a low level to maintain a stable arc. (Weman, 2003; Cary & Helzer, 2005; Balasubramanian, et al., 2008; Traidia, et al., 2010) The parameters of P-GTAW is shown in Figure 16.

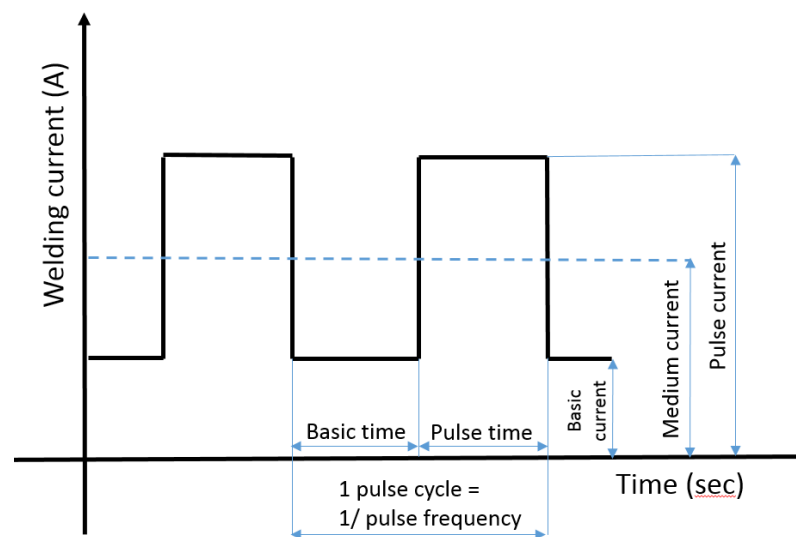

Figure 16: Pulse GTAW process parameter (Madadi, et al., 2012).

2.6 Progress with Submerged Arc Welding (SAW)

SAW of fillet welds is one of the major choice in the shipbuilding industry, its efficiency plays a significant role in determining the total ownership costs of ships. Submerged arc welding has significant advantages over GMAW including higher productivity, more stable arc, spatter-free, and harmful ultraviolet radiation-free. The principle of the SAW is quite similar to conventional GMAW, in which a continuously fed consumable electrode wire is melted to deposit metal into the workpiece. The process is unique as it protects the consumable wire, arc and weld pool from surrounding atmosphere by a covering envelope of molten flux and a layer of unfused granular flux particles. This allows the process to use

large welding currents without spatter and achieve high travel speeds. In-order to balance the melting rate of wire to set feeding speed, the power supply is set in CV mode. However the melting current is subject to change, since any variation in weld penetration affects base metal current which is same as the melting current, thereby affecting the melting-feeding balance of the wire. Sensing and control of weld penetration, the critical factors in the competitive next-generation manufacturing industry, are required to be improved to avoid potential defects and loss in productivity. (Li, et al., 2013) Significant increase in electrode deposition rates consequently higher weld productivity at the same heat input, can be achieved with the advanced inverter power source technology manipulating the AC waveform.

2.6.1 Double Electrode-Submerged Arc Welding (DE-SAW)

The DE-GMAW can weld at reduced heat inputs without any change in deposition rate. Conventional submerged arc welding lacks the capability to monitor and control weld penetration. When a GMAW gun is added into the SAW process to bypass part of the total current, the base metal current is reduced. Therefore the base metal current can be adjusted to control the weld penetration without reducing deposition rate. In the conventional SAW process, distortions in the welded structures arise due to the excessive heat input applied to achieve the required deposition rate. Here the heat input is directly proportional to the melting rate. The follow-up straightening process to remove the distortion is very costly. Inorder to mitigate this problem, the DE-SAW can be used, where the heat input is reduced because when the main wire melts, the total welding current is separated into base metal current and bypass current. Now part of the current is bypassed from without flowing into the workpiece. (Li, et al., 2007) However, the reduction in the heat input also reduces the penetration capability. The ability to produce required weld beads is compromised by this process (Lu, et al., 2013).

2.7 Developments in Laser Beam Welding (LBW)

Laser welding is a crucial joining technology to obtain welds with high quality, high precision, high depth-width aspect ratio welds at productive travel speeds with minimal distortion. LBW is a promising technology for automotive industries due to its high degree of thermal efficiency, very low thermal distortion of the weld assemblies, high speed welding and enhanced productivity in comparison with other fusion process. Also it has

wide applications especially manufacturing of tailor welded blanks and gear welding due to its reduced man-power, full automation, congeniality with a robot, systematization. (Katayama, 2005; Ghainia, et al., 2009; Victor, et al., 2011)

LBW uses the radiant energy carried in a very small beam cross-section of particularly very high power density, to concentrate on the boundary surfaces of the two parts to be welded together. During the LBW a high-power laser beam is focused onto a metal surface, which melts and vaporize the metal under the focus creating a weld keyhole eventually generating a weld bead. A laser beam has comparably higher energy density than a typical plasma arc. However the industrial implementation of the system is often perceived as a costly affair in the early days of its introduction due to its very low power conversion rates. But with recent developments in laser delivery techniques and resonator technology for CO₂, solid-state fiber, and disk laser configurations has improved the quality of high power laser beams with good conversion efficiencies. CO₂ lasers generally have an electrical to optical conversion efficiencies approaching 20 % with very good beam quality, high precision, high welding speed. Solid-state lasers supply beam powers around 10 kW to 50 kW while maintaining a high beam quality are available now in the manufacturing companies. Therefore, these lasers have a more compact footprint and much higher wall plug efficiencies than previous conventional lasers. The introduction of the fiber-optic delivery systems provided end-users with more flexibility in terms automation and compactness of the units. Variants of the LBW process such as Remote Laser Welding (RLW) allows the production of many weld stitches at a much faster rate than possible with robotic resistance spot welding. These systems have gained acceptance among manufacturers around the world for its application in automotive assembly operations, at the body shop, and at the subassembly level. (Ghainia, et al., 2009; Robert & Marianna, 2011; Blecher, et al., 2012; Moreira & Silva Lucas, 2012)

LBW is used for specialized operations where minimum heat-input and stress to the weld is required. For example investigations (Kawano, et al., 1998; Morishima, et al., 2004) on improving the weldability of the helium-containing irradiated materials using Nd-YAG laser beam proved to be successful. The LBW avoids weld cracking in irradiated steels when compared with GTA and GMA weld cladding methods with equivalent heat input. They

found that YAG lasers created very small weld beads with little heat input and stress to the material.

2.7.1 Remote Laser Welding Technology (RLW)

Most laser welding configurations can produce long continuous welds but are most often used to produce a series of weld stitches. Weld stitching is a demanding process in the automotive industries where RSW integrated with automated systems has dominated for quite long time. However now, RLW pose as a tough competitor with the developments in the Laser delivery technology. The RLW can perform remote weld stitches with different size and orientation based on the design requirements of the parts, whereas RSW can produce a round spot weld nugget of a size determined by the gun tip size. Programmable focusing optic scanners are used to perform the remote operations without requiring neither the part nor the scanner to be moved and scanners are mounted to a robot in-order to extend the working envelope for larger parts. Figure 17 shows the working principle and components involved in the RLW process. Significant reduction in cycle time can be achieved with RLW when compared to RSW, it is one of the primary motivations for factory owners to switch to RLW. Weld cycle time adversely affects the productivity of the manufacturing process. In case of RSW where several mechanical motions such as open gun, robot reposition to next weld site, close gun are required between each electrical weld cycle and they significantly affect the lead time of the product. For example a typical Robotic RSW unit requires 3 seconds to complete a single spot weld. However, a RLW unit has comparatively very fast welding speeds of several m/min. Additionally a considerable reduction in the deadtime between the welds can be achieved as small mirrors are required to be reoriented to point to the next weld avoiding any physical movement of weld gun to the next location. Figure 17 shows the time plot of the RSW and RLW where in RSW process the mechanical motions take up most of the cycle time, which results in low welding productivity (Robert & Marianna, 2011; Tracey & David, 2013).

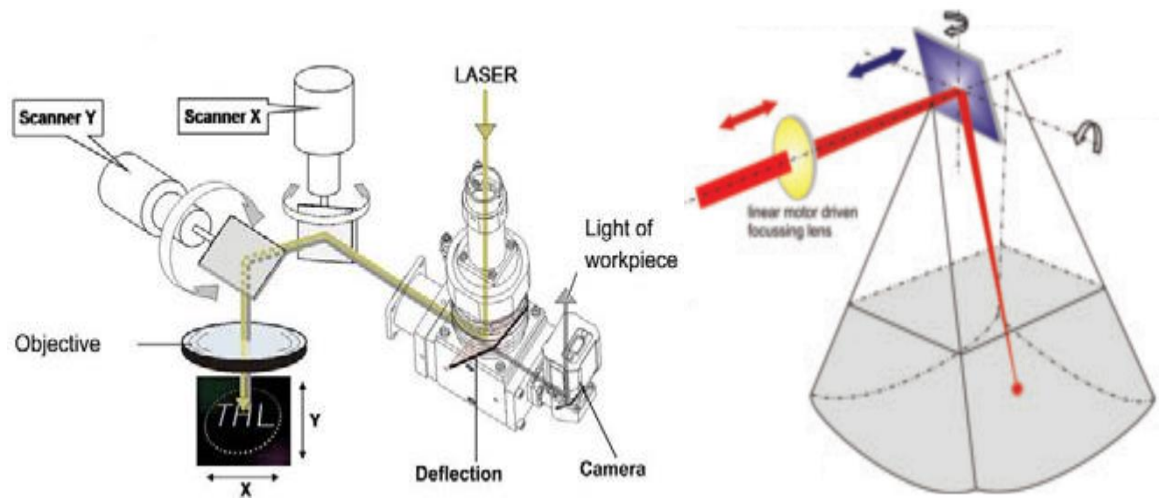

Figure 17: Working principle of remote laser welding (Robert & Marianna, 2011), (Tracey & David, 2013).

In contrast RLW requires only 0.4s to weld stich and mirror positioning requires 0.1s resulting in a highly productive weld (Robert & Marianna, 2011; Tracey & David, 2013). Therefore RLW is comparatively a cost effective process in moderate and high volume usage applications, a productive process with two to five spots a second.

3 ADVANCED MATERIAL CONTRIBUTION TOWARDS GREEN MANUFACTURING

Research focus on materials technology has been directed towards development of new materials that can meet the changing industrial needs. From the augmentation of steel to the enormous application of nanotechnology, advancement in material technology is set to yield revolutionary results in materials capabilities. In this section, based on the applications, the developments in material technology have been discussed. Development in materials directly reflects improvement in its properties. These material property improvements signifies reduction in material usage and scrapping, improved performance and improved life cycle of the product. These factors denote green manufacturing possibilities.

3.1 Developments in Power Plant applications

The use of nuclear power is expected to rise over the coming years all over the world to meet the energy demands of the future. The increasing demand for sustainable and steady supply of energy has led to significant changes in the materials used for these applications. At present, super critical and ultra-super critical power plants are being built to sustain extreme pressure and temperature to increase plant efficiency. Several types of advanced materials have been tried in the past including the dissimilar weld metals such as Austenitic stainless steels and ferritic steels for power plant tubing. However, potential failures occur in the dissimilar welds without warning thereby significantly affecting the cost of power production. In-order to provide an adequate design lives of about 30 years, new power plant designs need to be successfully implemented, however this hinges on the ability to develop materials with improved creep strength and corrosion resistance. Welding is an important part in manufacturing of critical components during initial fabrication, maintenance and repair, therefore simultaneous developments in improving the welding characteristics of these newer alloys are required.

Nickel based alloys play significant role in energy production sectors, used for manufacturing of critical components, since they often provide high levels of temperature strength and corrosion resistance that are higher than those obtained with ferritic steels or austenitic steels. In some cases, the required level of high temperature strength and corrosion

resistance can only be met by Nickel alloys. Nickel based alloys have certain characteristics that make them unique. This includes its capacity to dissolve high concentrations of alloying elements compared to other metals and its ability to form highly protective Cr_2O_3 surface oxide layer with excellent corrosion resistance when Cr is added to Ni. (DuPont, 2014)

The current industry standard for corrosion protection of waterwalls in boilers operating with low- NO_x burners include commercially available nickel based weld cladding due to their excellent resistance to corrosion (Deacon, et al., 2007). However experiments (Luer, et al., 2001) have proved the susceptibility of these alloys to premature failure due to corrosion-fatigue cracking. These problems can be mitigated and cracking resistance can also be improved by the use of coatings applied in the solid state with uniform heating. Research has been carried out to eliminate the inherent problems of weld cladding with help of coatings made by co-extrusion process. In this process, explosive welding supports joining of the steel substrate and the cylindrical shells of corrosion resistant alloys, then a bimetallic billet at high temperature is coextruded to produce a tube with outer coating. The co-extrusion coating reduces the factors promoting corrosion fatigue such as localized stress concentrations, by allowing uniform coating thickness and smooth surface finish. Also the uniform and less severe cycles of heating and cooling experienced during co-extrusion significantly reduces the residual stresses in the material. (DuPont, et al., 2013; DuPont, 2014) Thus significant improvement has been made in regard with premature failure of nickel based alloys due to corrosion-fatigue cracking.

Handling nuclear waste (spent nuclear fuel) is considered to be one of the major challenges associated with nuclear energy production. Therefore development of special thermal neutron-absorbing structural materials are required for nuclear criticality control. Gadolinium (Gd) enriched Ni-based alloys have been recommended by recent research (Hull, et al., 2000; DuPont, et al., 2004; Susan, et al., 2006). The result of the recent research highlights the possibility of adding nominal 2 wt-% level to the commercial Ni-based C-4 alloy yet without any major changes to its hot workability, weldability and mechanical properties. However it is important to analyse the influence of Gd concentration on the solidification cracking susceptibility of Alloy C-4, so that these structural materials can be welded while maintaining their structural integrity.

Nickel based filler metals showed 3 to 5 times improvement in life over stainless steel filler metals. However, they could not meet the changing requirements of the highly advanced power plants. The new filler metals such as the EPRI P87 was developed to meet problems related to thermal expansion coefficient mismatch and carbon migration. These filler metals showed good resistances to micro fissuring. Various grades of chrome-moly steels were developed in the past especially for the fabrication of pressure vessel and boiler piping. This is due to its high-temperature strength and good corrosion resistance. However joining these steels require filler materials that have ability to provide same properties. Manufacturers are concerned with developing filler metals with low X factor which represents the resistance of weldment to temper embrittlement. (Roberts, et al., 1987; Chandravathi, et al., 2010; Siefert, et al., 2011) Today new T5 gas shielded flux cored wires have been developed such as American Welding Society (AWS) E81T5-B2M H8 and E91 T5-B3M H8 wires. These wires are readily able to weld out of position, particularly uphill and downhill thereby enabling welders to weld already installed piping systems and in welding shop. The AWS - E81T5-B2M H8 wires can provide welds with reliable toughness properties, low levels diffusible hydrogen and a very low X factor. These wires are designed for welding chrome and molybdenum steels and reduce the temper embrittlement and cracks susceptibility. (Keith, 2011)

3.2 Developments in Aerospace applications

The best way to achieve weight reduction is through selection of lighter materials. Aerospace vehicles employ a wider range of materials to attain lighter weight. Aluminium alloys have been one of the primary choice in the material selection for commercial and military aircrafts and in the marine sectors for more than 80 years. This is probably due to their well-known mechanical behaviour, easiness with design, manufacturability and established inspection techniques. Modern composites because of their excellent fatigue performances, corrosion resistance, reduced weight and high specific properties appears to be a tempting replacement for aluminium alloys; however its higher initial cost and expensive maintenance, limits its widespread use in airframe construction. Aircraft manufacturers adhere to the life cycle approach for selection of materials as cost reduction has become the main criteria in many airlines. Nowadays highly customized aluminium alloys are developed to meet the requirements of aerospace industries, which can effectively compete with composite materials. Increasing application of aluminium in various industrial

sectors is the main driving force for technologists to develop a viable and efficient technology for joining aluminium alloys.

The excellent damage tolerance and high resistance to fatigue crack propagation of 2024 aluminium alloy in T3 aged condition has made it an important aircraft structural material (Zehnder, 1996). The 2024 alloy had 17% improvement in toughness and 60% slower fatigue crack growth rate compared to other 2000 series alloys (Smith, 2003). However, the application of this alloy is limited to the highly stressed regions because of its low yield stress level and relatively low fracture toughness (Verma, et al., 2001). Significant improvements in the design properties associated with fuselage skin durability were attained with 2524 aluminium alloy and the corrosion issues were addressed by surface cladding on the interior of Boeings 777 jetliner. Thus the 2024 alloy was replaced by the 2524 aluminium alloy in the fabrication of aircraft fuselage skin in the Boeing 777 Jetliner. (Golden, et al., 1999; Smith, 2003) Fatigue strength of the 2524-T34 alloy is 70% of the yield strength whereas for 2024-T351 fatigue strength is about 45% of the yield strength (Zheng, et al., 2011). The 2524-T3 alloy, when compared with 2024-T3 alloy is able to provide 15% to 20% improvement in fracture toughness and twice the resistance to fatigue growth (Smith, 2003), thereby leading to weight savings and 30 to 45% longer service life (Golden, et al., 1999). The main reason for the better performance of 2524 alloy is due to its less damaging configuration for corrosion features. Slow fatigue crack growth rates of 2524 alloy also contribute to its difference in life (Golden, et al., 1999). Similar fracture toughness, corrosion resistance levels and higher strength values than 2024-T351 have been obtained with 2224-T351 and 2324-T39 alloys for lower wing skin applications (Necsulescu, 2011).

Among all the aluminium alloys, the Al–Zn–Mg–Cu versions have proved to exhibit the highest strength. Addition of 2% copper in combination with magnesium and zinc could significantly improve the strength of the 7000 series alloys. The highest tensile strengths obtainable with aluminium alloys have been developed in Alloy 7075 (5.5% zinc, 2.5% magnesium, 1.5% copper), alloy 7079 (4.3% zinc, 3.3% magnesium, 0.6% copper), and alloy 7178 (6.8% zinc, 2.7% magnesium, 2.0% copper). Although these alloys have proved to be the strongest they have the least resistance to corrosion. However, susceptibility of these alloys to stress corrosion cracking can be controlled with proper heat treatment and

with addition of some materials like chromium. New versions of the 7000 series alloy have been developed with higher fatigue and corrosion resistance that has resulted in weight savings. (Avner, 1997; Campbell, 2006) Alloy 7050 has a very good balance between the resistance to stress corrosion cracking, strength and toughness. Alloy 7050-T76, without any compromise in strength have solved the problems related to corrosion in 7075-T6. Excellent fatigue performance, higher toughness and comparable strength to 7075-T6 has been achieved with 7050-T76 alloy. The higher copper content in 7075 is the main reason for its excellent combination of strength, corrosion characteristics and SCC resistance. (Staley & Lege, 1993) However, low toughness and environmental sensitive fracture-in-service, particularly under cyclic loading conditions have restricted its application (García-Cordovilla, et al., 1994). Higher strength and superior damage tolerance than 7050-T76 alloy can be achieved with 7150-T77 extrusions (Staley & Lege, 1993). Boeing 777 Jetliner's fuselage stringers (longitudinal members) were fabricated with 7150-T77 extrusions as they offered high strength, corrosion resistance and fracture toughness. However, 7055-T7751 plates resulted in estimated weight savings of upto 635Kg in Boeing 777 jetliners and this alloy was able to provide 10% gain in strength, higher toughness and significantly improved corrosion resistance (Smith, 2003), (Warner, 2006). From studies it has been observed that the 7475 alloy has better performance and under proper treated condition the 7475 alloy can be used to reduce the overall weight of the aerospace structure thus replacing the generally used 7075 and 7050 alloy versions. Verma et al (2001) reported that the 7475 aluminium alloy, a modified version of the 7075 alloy has an excellent combination of high strength, resistance to fatigue crack propagation and superior fracture toughness both in air and aggressive environment. And so this controlled toughness alloy with above mentioned properties is best suited for aerospace application which demands similar property requirements.

Third generation Aluminium-Lithium (Al-Li) alloys have generally good-to-excellent stress corrosion cracking (SCC) resistance when compared to conventional 2xxx plate alloys. These alloys such as the 2099 and 2199 were used in manufacture of fuselage skin-stringer components. The combination of alloy 2199-T8E74 used as fuselage skin material and alloy 2099-T83 used as stringer material were 5% lighter than the 2524 and 7150 combinations for the same purpose. (Heinimann, et al., 2007) Al-Li alloy products such as 8090 and 2091 offers superior resistance to fatigue crack growth and also exhibits 6-7%

weight savings over 2024-T3 because of low density. So these alloys have been attractive option for the fuselage skin of the airplanes (Staley & Lege, 1993). Similarly Aluminium-Lithium alloys find applications in development of space shuttle. Aluminum–Lithium composite (Al–Li 2195) replaced the Al 2219 for development of space shuttle's external tank developed by Lockheed Martin, a substitution which reduced the total weight of the external tank by 3400 kg (National Aeronautics and Space Administration, 2001).

Metal matrix composites (MMC) finds potentially successful engineering applications in aerospace structures, therefore they become one of the hot topics in research related to joining sciences. Aerospace application use high elastic modulus of ceramics and high metal ductility to achieve better combination of properties. Very high strength to weight ratio of the MMC's which has metal alloys reinforced with ceramics, makes it attractive for use in the aerospace applications. MMCs are structures which contains two or more macro components that dissolve within one another. However solutions are yet to be found for problems related to joining metal matrix composite materials (especially the ceramic-reinforced aluminum alloy matrix composites) using fusion welding processes. Lack of thermodynamic balance between the metal and ceramic due to their difference in chemical and physical properties is the major cause for problems such as undesirable intermetallic-compounds (IMC) formation, uncontrolled solidification and micro-segregation or inhomogeneous distribution of reinforcement material. However FSW tries to solve these problems with its unique method of joining the materials. The high strength to weight ratios and high strength to density ratios of the MMCs played an important role in development of Hubble Space Telescope's antenna mast, the space shuttle Orbiter's structural tubing, control surfaces and propulsion systems for aircraft. However joining these materials is a difficult process that involves formation of an undesirable phases (as molten Aluminium reacts with reinforcement), leaving a strength depleted region along the joint line during fusion welding. FSW stands out to be game changer in joining these materials, as welding occurs below the melting point of the work piece material, therefore the deleterious phase is absent. FSW is an effective method to join the MMC especially in the arrow space industries. Although rapid wear of the welding tool is a major problem due to large variation in hardness between the steel tool and the reinforcement material. Therefore effective FSW tool material needs to be researched to counter the abrasive wear phenomenon. These tools include diamond coated tools, tungsten carbide and high speed steels. Hence effective

monitoring to reduce the tool wears in FSW of MMC is essential to implement these materials in complex applications. (Celik & Gunes, 2012; Prater, 2014)

The 4043 filler material is the most popular filler alloy used in general purpose aluminium welding application. The conventional 4043 filler metal has significantly lower strength compared to 5xxx series alloys and significant variation in weld strength based on weld condition. Therefore the filler metal 4943 was developed for arc welding the aluminium base alloys as they have significant advantages over the conventional filler metals such as 4043 and 4643 alloys. The newer 4943 filler metal is a perfect high tensile, yield and shear strength alternative to 4043 filler metal while retaining its other advantages such as ease of welding, excellent corrosion characteristics, low hot-cracking sensitivity. In addition, 4943 filler metal is heat treatable therefore improved strength characteristics could be obtained in the post-weld solution heat treated and artificially aged condition. (Tony, 2013)

3.3 Developments in Oil and Gas applications

Over the years, piping industries supporting the production of oil and gas resources have accepted 13% Cr steel as the standard countermeasure for carbon-dioxide induced corrosion cracks in pipeline welds due to its good corrosion resistance. Pipeline industries have heavily relied on micro-alloyed steels of high strength and low alloy for their excellent combination of high yield strength, toughness, and weldability. Optimized thermo-mechanical treatment and low alloy additions such as Nb, Ti, and V have promoted grains of very small sizes. Oil and gas industries have been upgraded with newly improved Super-martensitic stainless steels (SMSS) which are based on the conventional martensitic stainless steels (11-14% Cr) but with added Nickel and Molybdenum to enhance free-ferrite structure and reduced carbon content to enhance weldability and corrosion resistance. Therefore, they act as an effective alternative to high-strength low-alloy (HSLA) steels. These materials have good weldability and high resistance to sulfide stress cracking. The austenitic stainless steels find cryogenic applications in the chemical, petrochemical, and metallurgical industries, as the ductile/brittle transition temperature doesn't occur except for in the weld metal. (Marshall & Farrar, 1998; Kvaale & Olsen, 1999; Lippold & Kotecki, 2005)

3.4 Developments in Shipbuilding applications

The principle structural materials used in naval shipbuilding requires an excellent combination of material properties, in-order to sustain extreme sea conditions yet maintain low level additions of expensive alloying elements. Peculiar characteristic requirement for materials operating in arctic conditions have significantly risen in the recent years with expanding offshore applications. Recent report (Kitagawa & Kawaski, 2013) suggests that steels having 0.2% yield strength of 500MPa to 690MPa are more favourable choices for material selection in these harsh environments than the conventional steels. Stringent requirements for applications at -30°C to -40°C have been drawn in utilization. *Table 6* shows the different methods to improve the toughness in the welded material High-yield (HY) and High-strength-low-alloy (HSLA) steels have been adopted in shipbuilding application mainly due to its good combination of high strength and low-temperature toughness properties. HSLA steels with very low-carbon content and alloying additions such as Mo, Nb, Ti, V, Mn, Cu, Cr, Ni, have chemical compositions which exhibits excellent mechanical properties and have better resistance to hydrogen-induced cracking compared to mild steels. For example, NUCu-140, a high-strength low-carbon (HSLC) steel has nanoscale Cu-rich precipitates for strengthening in a ferritic matrix microstructure. NUCu-140 can achieve reduced costly alloy usage and reduced total material usage due to increased strength levels consequently reducing the overall expense of the project. (Fine, et al., 1993; Czyryca, 1993; Leister & DuPont, 2012; Yue, et al., 2012) Blast resistant steels were developed for naval surface ships using computational materials design concept. The Blast-Alloy 160 (BA-160) steel was developed with high yield strengths of upto 1100MPa and impact toughness of 176J at 25°C for use in naval ships. The combination of martensite-bainite matrix, M₂C (M represents Cr, Mo and V) and copper precipitates played an important role in strengthening of BA-160. The finely dispersed nickel stabilized austenite promotes high toughness. (Saha & Olson, 2007)

Table 6: Suggested methods to improve the toughness in the welded material (Kitagawa & Kawaski, 2013).

Materials with Yield strength	Microstructure	Methods to enhance toughness of the weld metal		
		Toughening matrix	Refinement of microstructure	Formation of acicular ferrite
<= 500MPa	Ferrite + Pearlite	Addition of Ni	Addition of Mo Reduction of O	Addition of Ti and B
>= 600MPa	Bainite + Martensite	Increase of Ni	Reduction of O	Introduction of nucleation site (Ti oxide)

3.5 Developments in Automotive applications

Automotive industries invest huge amount of money and time in developing advanced materials such as aluminum alloy, magnesium alloy, plastics, and carbon-fiber-reinforced plastic that can reduce fuel consumption, enhance passenger safety and improve mechanical properties of the next generation vehicles (Furukawa, 2006).

Ferritic stainless steels have been in spotlight in the past years for its better corrosion resistance and lower cost when compared to austenitic stainless steels. For example automotive exhaust systems were fabricated with low chromium grades for its fair corrosion resistance and low cost fabricability. These steels are not a favorite choice for applications that require welding due to the grain-coarsening problem that occurs at weld zones resulting in lower toughness at low temperatures and lower strength at high temperatures when compared to austenitic steels. However with introduction of lean alloyed chromium stainless steels, the level of control on material composition has significantly increased resulting in extremely low levels of carbon and nitrogen with consequent improvement in corrosion performance and HAZ properties. The 12% Cr transformable stainless steels were developed with precise control over carbon content thereby avoiding the extremes of completely ferritic or martensitic structures. Although these steels provided excellent corrosion resistance and good economic advantage over austenitic stainless steels, their limited weldability and low impact toughness at HAZ have resulted in avoiding the use of these steels in applications involving dynamic loads. Therefore a modified 12% Cr stainless

steel was fabricated which displays the advantages of stainless steels for corrosion resistance and engineering properties of carbon steels and hence considered a perfect link between carbon steels and corrosion-resistant alloys (Yang, et al., 2011; Taban, et al., 2012).

Nano-engineering is an effective tool to exploit the potential of steel. The first is the grain refined Interstitial-Free Advanced High-Strength Steels (IF AHSS), which was developed and commercialised by optimising the distribution of Nano-precipitates. The steel exhibits low yielding ratio in spite of being strengthened by grain refinement and precipitation hardening. The second is the new ferrite single phase TS 780 MPa grade hot rolled AHSS, which was developed and commercialised with utilising thermally stable Nano-sized carbides by coating Ti and Mo. The steel sheet possesses significantly well balanced elongation and stretch flangeability. The last is the UHSS, of which the formability is enhanced by combining tempered martensite with bainite containing retained austenite. This steel with 1470 MPa TS exhibits larger elongation than dual phase steels with TS 590 MPa grade, although further optimisation of the composition and the processing are needed to be produced and commercialised. (Seto & Matsuda, 2013)

Use of the lightweight materials is one of key enabling technologies for vehicle weight reduction and improving the fuel efficiency. These lightweight materials include advanced high strength steels, aluminum, magnesium as well as the plastic and composites. Among these materials, aluminum, which provides the high strength to weight ratio together with excellent corrosion resistance, is one of promising materials and are increasingly used in the automotive industry. Such application comes with the challenges of avoiding burn-through and finding ways to bridge the joint gaps, without increasing the costs significantly. Magnesium alloys, with their unique properties such as lower density, electromagnetic shielding, and damping capabilities, have attracted the automotive industries in recent years. Magnesium alloys prove to be very useful in manufacturing the structural parts of the vehicles where a significant reduction in weight is required. The application of steels with strengths of 1 GPa and higher to automotive bodies has helped to increase their durability while reducing their weight. These newly developed AHSS were able to reach the objective of weight reduction and crashworthiness, but any further reduction of weight by 30% was highly impossible without the usage of multi-material structures. (Sakiyama, et al., 2013) Multi-material structures have been on the spotlight of the civil and defense vehicle

manufacturing industries in view of its peculiar properties (Li, et al., 2003). Materials such as dissimilar Ti-Cu alloys meets demand of light weight and high strength materials and also satisfies the requirements of heat conduction, electrical conduction, wear resistance and corrosion resistance. However, fusion joining of titanium and copper has metallurgical challenges due to differences in their chemical and physical properties and due to formations of brittle Ti-Cu intermetallic compounds (IMCs) at elevated temperatures seriously degrading the mechanical properties of the joints. (Shiue, et al., 2004; Aydin, et al., 2012) The available evidences (Movahedi, et al., 2012; Nigel & Kevin, 2012; Ogura, et al., 2012) seems to suggest that the best combinations for the multi-material structures in the automotive industry are aluminium alloys and advanced high strength steels and magnesium alloys and advanced high strength steels. Still these materials are highly difficult to be welded together due to their differences in mechanical and physical properties resulting in brittle joints which is due to formation of large amounts of brittle IMC's. In general, brittle intermetallic layer are formed in the weld during the welding process, which influences the mechanical properties of the weld. These intermetallic compounds can form easily at relatively low temperatures and become the source of cracks that can significantly reduce the mechanical properties of the joints. However promising welding techniques are developed to meet the requirements. For example Rathod & Kutsuna (2004) incorporated a laser roll welding technique with aluminum brazing flux to weld low-carb on steel to aluminum alloy 5052. It was found that increasing the laser welding speed thinned the thickness of the brittle intermetallic layer, thus enhancing the weld shear strength. Hybrid laser-GTAW process was successfully used in joining the Mg-Al-Zn alloys and Q235 mild steel. Similarly the addition of interlayers promoted the joint plasticity. Resistance spot welding and friction stir welding were used to weld aluminum to steel. (Oikawa, et al., 1999; Reddy, et al., 2008; Qi & Liu, 2011)

3.6 Developments in Mining Industries.

The excavators used in the mining industries require materials with high hardness and excellent wear and corrosion resistance to mine the earth. Therefore critical components of these machines such as the hammer are manufactured from Fe-Cr-C alloy which has excellent abrasive wear resistance mainly due to the distribution of carbides. Similarly Tungsten carbide (WC) with very good thermal shock resistance and good wear resistance has been used in reinforcing the high-Cr white cast iron to improve the usability of these

materials in applications where extreme wear resistance is required. Rare earth elements such as the Vanadium (V), niobium (Nb), and titanium (Ti) have excellent properties which when added to the steel, significantly refined their microstructure and improved the wear resistance of the Fe-Cr-C alloy. (Zhou, et al., 2012)

3.7 Developments in Offshore applications

Development of higher strength and greater toughness materials are required for solutions in construction of arctic and offshore structures. These harsh environments have several tough requirements for construction of structures in those conditions. In particular, advanced welding consumables are developed for a variety of commercialized welding process in view of achieving higher impact toughness, higher yield strength and higher CTOD values at sub-zero temperatures. To emphasize this, reports from Kitagawa & Kawaski (2013) stated that they developed advanced consumables for shielded metal arc welding (SMAW), submerged arc welding (SAW) and flux cored arc welding (FCAW) by adjusting the basicity of the flux to achieve reduced oxygen content in the weld metal. This ultimately led to development of consumables with very good impact toughness down to -60°C, higher yield strength of over 500MPa and High CTOD value down to -40°C. Various welding consumables are selected according to the material's strength classes like different steel grades, chosen for the construction.

Reducing the oxygen content in the weld metal ensures very high toughness. Figure 18 shows the effect of oxygen content in the weld metal to the percentage of brittle fracture at -74°C for Charpy impact test (SMAW), prepared with adjusted basicity. In-order to reduce the oxygen content in the weld metal, Kitagawa & Kawaski (2013) experimented by adjusting the basicity level (BL) of the covering material used in the shielded metal arc welding. The result was that they were able to develop a new wire "LB-67LJ", which satisfied the requirement for producing welds with 60mm thick plate yet maintaining the strength ($\leq 500\text{MPa}$) of the weld metal at the required values and higher CTOD values even at the welding heat input of 4kJ/mm.

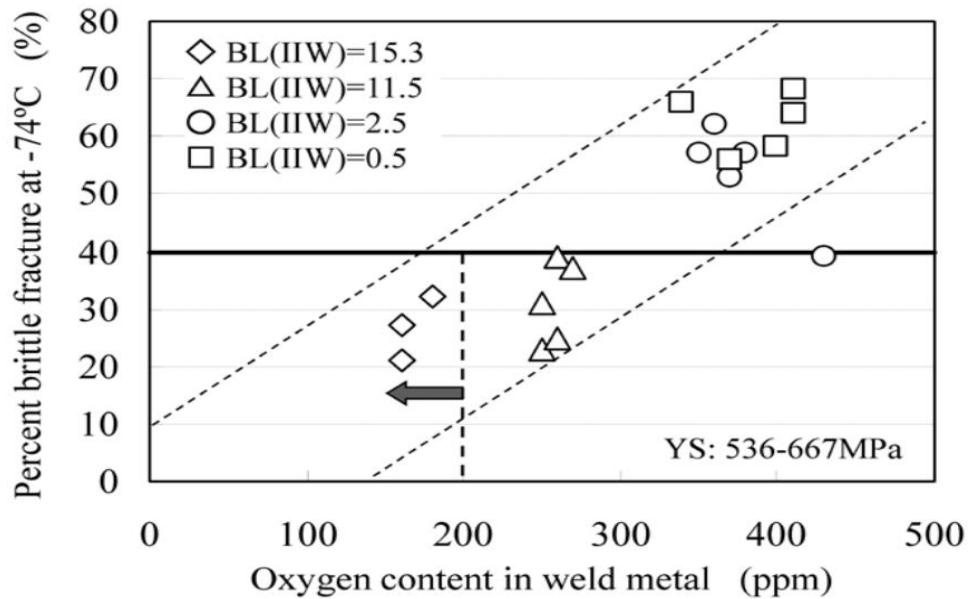

Figure 18: Effect of oxygen content in weld metal on the percentage of brittle fracture at -74°C for Charpy impact test (SMAW) (Kitagawa & Kawaski, 2013).

Significant minimization of distortions in welded assemblies due to developed residual stress during cooling can be achieved with low transformation temperature welding (LTTW) wires. Structural weld joints in most cases are significantly affected by the residual stresses developed during joining of low-carbon structural steels. Therefore the LTTW wires were developed to produce martensitic transformation close to room temperature thereby managing the residual stresses and improve the fatigue strength of the joint. Tensile residual stresses are developed in low-carbon structural steel weld joints when the weld is cooled to the room temperature. However using the LTTW wires induces the compressive residual stress that counteracts with existing residual stresses. A martensitic microstructure within the fusion zone is achieved with these wires. The presence of Cr and Ni in these wires are effective in reducing the ‘Martensite transformation start temperature’ (M_s), increasing the martensite and reducing the weld distortion. (Alghamdi & Liu, 2014)

Offshore applications including the setup of Jack-Up oil rigs, have extreme requirements to sustain the violent and low temperature seas. The ASW E81T8 Ni2 J and AWS E111T1-GM H4 were developed for welding of X80 pipelines and also for other applications such as shipbuilding and structural fabrications applications. These wire are capable of providing high tensile strength, good impact toughness, low spatter levels, easy to remove slag and the smooth and stable arc. (Keith, 2011)

3.8 Development in Process Industries

The chemical process industries such as the agriculture and pharmaceutical sectors require materials such as Ni-Mo alloys with high resistance to corrosions or high resistance to sulphuric and hydrochloric acids. However these nickel alloys are still susceptible to corrosion attacks by dissolved oxygen and ferritic or cupric ions. Therefore the Ni-Cr-Mo alloys were developed which displayed excellent corrosion resistance in oxidizing media and excellent pitting and crevice corrosion resistance in presence of hot chloride salt solutions but with limited resistances to hydrochloric and sulphuric acid. A newer hybrid Ni-Cr-Mo alloy has been developed with good corrosion resistances to sulphuric acid and better resistance to hydrochloric acids than the previously mentioned alloys. (Caron, et al., 2011)

4 INTELLIGENT WELDING SYSTEM CONTRIBUTION TOWARDS GREEN MANUFACTURING

Adopting robotic systems, sensor technologies and other weld management systems allows more effective control of quality, improves productivity, reduces wastage and facilitates accurate planning. Intelligent welding systems can measure the component to be welded, automatically adjust the weld parameters during welding based upon the information retrieved, document the entire process and prepare automated reports of the produced welds. Based on the sensor information such as weld path, intersections, seam trajectory and other obstacles, the robots can perform successful weld operations. The need for the operator to set the welding process parameters is avoided as these parameters can be determined from databases and algorithms. The intelligent welding systems can make automated real time corrections of the parameters based on the algorithmic and sensor assessment. Therefore the automated systems increase process productivity, reduce repair rates, improve weld quality and save energy and material through optimisation. These improvements promote green manufacturing.

4.1 Developments in Robotic and Automated Welding Systems

For more than 50 years, industrial robots have been implemented in manufacturing industries to perform the arc welding processes. The evolution of the robotic technology since its inception in welding process had gradually developed over the years as a mature technology with more flexibility, capacity and compactness. Improvements in servo and electronic industries have promoted the ability to control robots in a more effective way. The computer controlled servo technology allowed the robotic machines to precisely replicate the motions of a human hand. (Vern, 2011)

4.1.1 Articulating Weld Robots

Industries especially the automotive and aerospace industries have benefited from the introduction of robotic manufacturing units. While manufacturing automotive components, arc welding robots as shown in Figure 19 have become critical in production sites to ensure a continuous and steady flow of manufactured components. Robotic welding is best suited for higher volume and lower variety of applications especially for situations with simple and

consistent parts such that the robots could repeatedly perform welds in the same locations. Workflow is important in robotic manufacturing units. Consistent supply of parts need to be ensured as delays in upstream parts could significantly affect workflow and cause bottlenecks resulting in costly downtime. Systems have been developed for robotic units where preliminary assessment using the Computer Aided Drawing (CAD) drawings of the job creates a software simulation that assesses the suitability of the part for welding automation. They also support for fine-tuning of the tooling to have an optimized and smooth workflow. Similarly sensing systems such as the vision based sensing, touch sensing have been integrated into the system for efficient working and minimal human intervention. The consistency in weld production using robotics along with other advantages, makes the companies adopting robotic technology gain a competitive edge. However additional costs are required for tooling during production. The time required for payback of robotic welding systems varies depending upon the part volume, time required for manually welding them and comparison based on potential cycle times of a robotic welding system. Therefore, companies need to implement proper set of tooling, if their production volume is low and have variety of applications. (Vern, 2011)

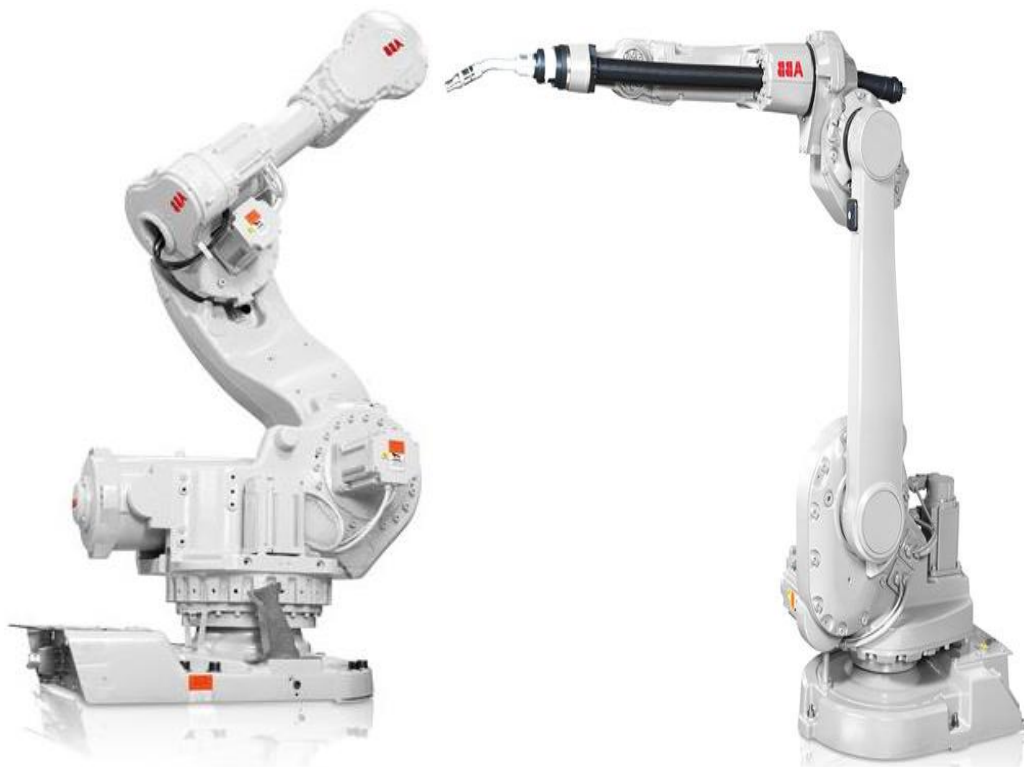

Figure 19: Robotic welding machines with heavy load carrying capacity of up to 500kgs (ABB, 2015).

Skilled Robotic programmers are required for effectively managing the robotic welding process. Continuous training support from robot manufacturers is required to constantly update the operators with programming, troubleshooting errors and perform preventive maintenance. Continuous developments in standardization and harmonization of the language and specification used by these robots are required to make their application commercially successful in a competitive environment. The essence of robotic arc welding would never be realized fully if the technology lacks safety measures in the workshop. Proper selection of robots according to their applications and requirements are a must to ensure their efficient and safe usage. The application list for the robotic technology in welding increases with complex component design and with joining of special materials such as the high strength metals and dissimilar metals. Robotic welding systems can improve upon the productivity of the process by not only offering high speed and greater productivity but also by improving the weld cosmetics, reducing the reworks and repairs, reducing over-welding and by reducing labor costs. (Vern, 2011)

4.1.2 Industrial Weld Positioners

In-order to increase the safety and to achieve the best possible output in the workspace weld positioners are used. A variety of shapes and sizes of weld positioners are available in the market today to ensure better handling of the components and to make the weld job much easier. Weld positioners supports the welder by creating a sturdy base for welding and adjusting the weldment in the required optimum angle for easy accessibility; this helps the welders to accomplish the welding task quickly and in a small work area. When dealing with heavy machinery, weld positioners are a must, to ensure safety of the personnel; however they aren't only built for and utilized in the heavy machinery trade, but also for application in the automotive, heavy construction, oil and pipe, and defense industries, among others. The demanding applications of the weld positioners range from the agricultural industries to the aerospace manufacturing industries. (David, 2014) As weld positioners have become a necessary tool in workplaces to increase the productivity and safety, the positioner manufacturers have developed several designs (as shown in Table 7, Table 8, Table 9) to suit for a variety of applications. This includes the five axis positioners, sliding tailstock trunnions, ferris wheel positioners, L-hook positioners and dual trunnion turntables (David, 2014).

Table 7 : Different types of positioners available in the market (1/3) (David, 2014).

Types of Positioners	Features
 <p data-bbox="446 1048 798 1086">Sliding tailstock positioner</p>	<ul data-bbox="1013 548 1460 862" style="list-style-type: none"> • Can accommodate multiple payloads using adjustable tailstock. • Floor mounted Headstock with precision bearings. • Slide is coordinated with robot.
 <p data-bbox="406 1774 837 1812">Ferris Wheel Welding Positioner</p>	<ul data-bbox="1013 1265 1460 1646" style="list-style-type: none"> • Easy integration with robot • Long horizontal exchange axis minimizes station footprint and accommodates longer parts • Metal arc screen safeguards operator from arc flash • Versatile in handling long parts

Table 8 : Different types of positioners available in the market (2/3) (David, 2014).

 <p data-bbox="486 1041 758 1075">Five-axis Positioners</p>	<ul data-bbox="1005 515 1412 828" style="list-style-type: none">• Ergonomically friendly positioner height• Higher flexibility in rotating the work• Access to difficult-to-reach areas in the workpiece.
 <p data-bbox="494 1803 750 1836">L-Hook positioners</p>	<ul data-bbox="1005 1344 1436 1601" style="list-style-type: none">• 2 axis positioners with 360 degree rotation on both main and table axis• Mainly used in GMA welding of agricultural equipment.

Table 9 : Different types of positioners available in the market (3/3) (David, 2014).

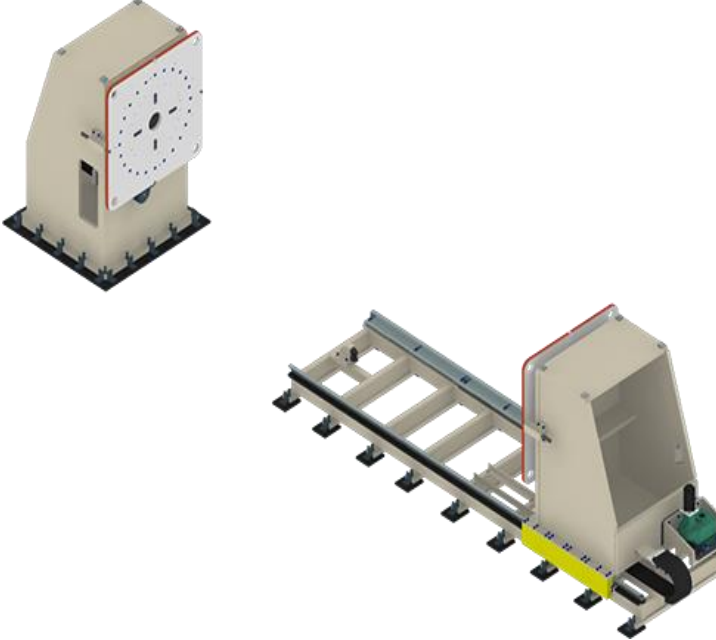
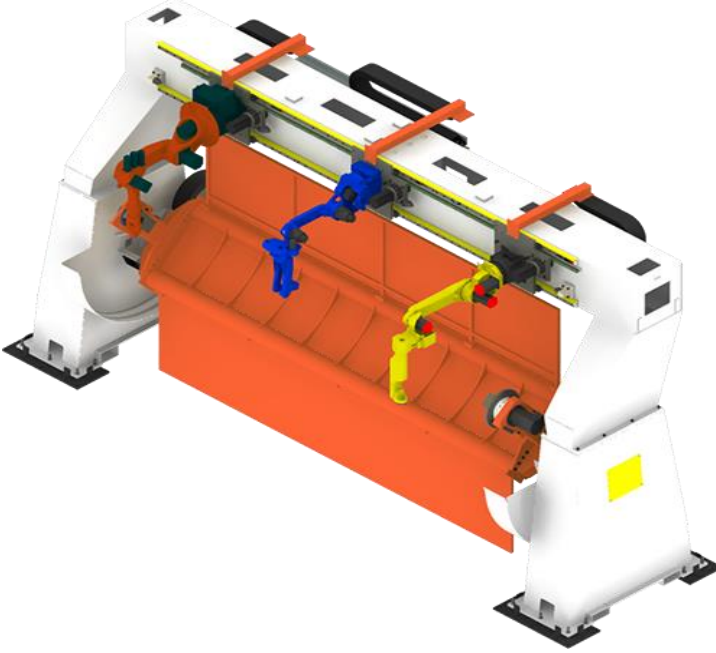

4.2 Developments in Weld Monitoring Systems

Most of the current welding robots implemented in the industries are still the teaching and playback type robots. The weld results from these robots however, are yet to meet the quality standards and diversification requirements needed in the fabrication industries. This is because these systems lack the ability to adapt to changes both within the system and outside of it. However with continuous development in the electrical and electronic industries it has become inevitable to realize the rise in demand for intelligent welding systems. To develop an effective intelligent welding system, sensing of the weld pool is fundamental because the weld pool encodes significant amount of information about the welding process. Therefore appropriate feedback signals must be obtained which in-turn will support the generation of suitable error signal to correct the welding systems. Feedback signal can be obtained by monitoring the variable welding parameters or by employing appropriate sensors. A wide variety of sensors are used to detect and track the weld joint, and to monitor the welding phenomena. For example, automatic tracking of the weld joint is possible with sensors such as the tactile, vision, and arc sensors. Machine vision systems help automated welding systems to visually observe the weld pool in two or three dimension to extract the information and adjust welding parameters accordingly. Table 10 provides various sensors used for monitoring and collecting data from the weld pool.

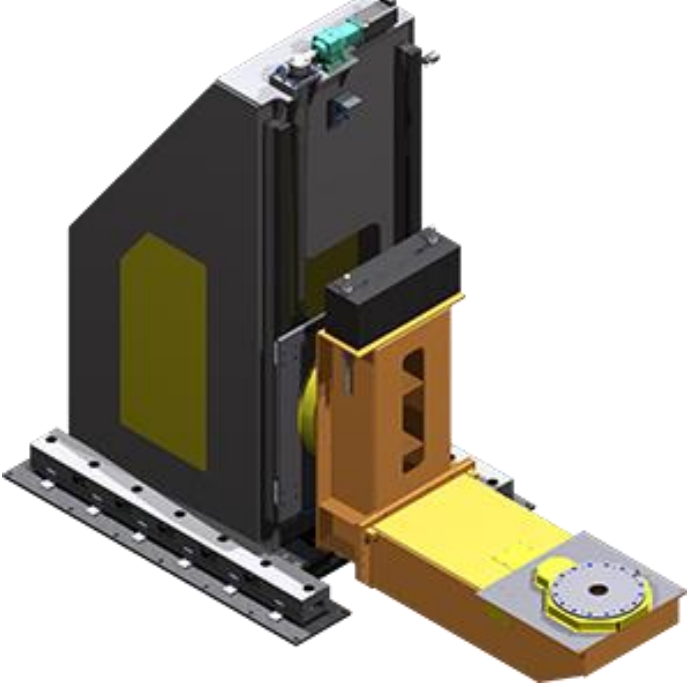
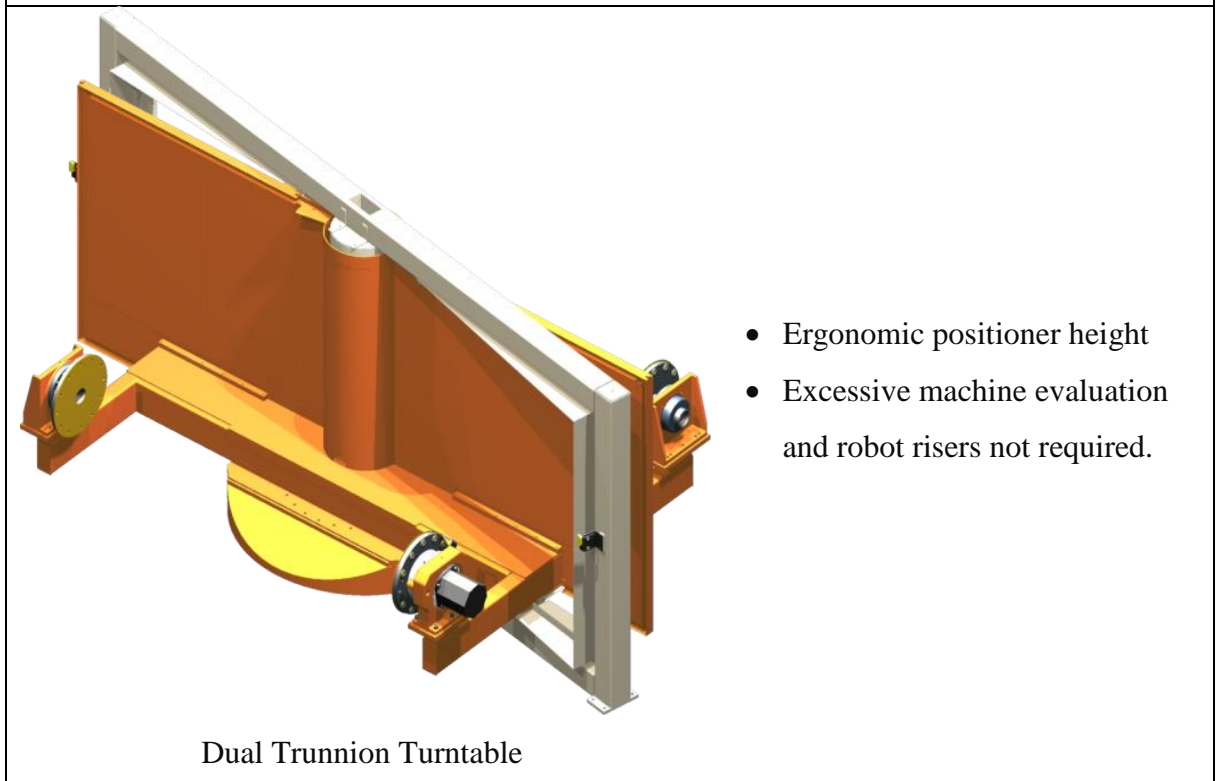
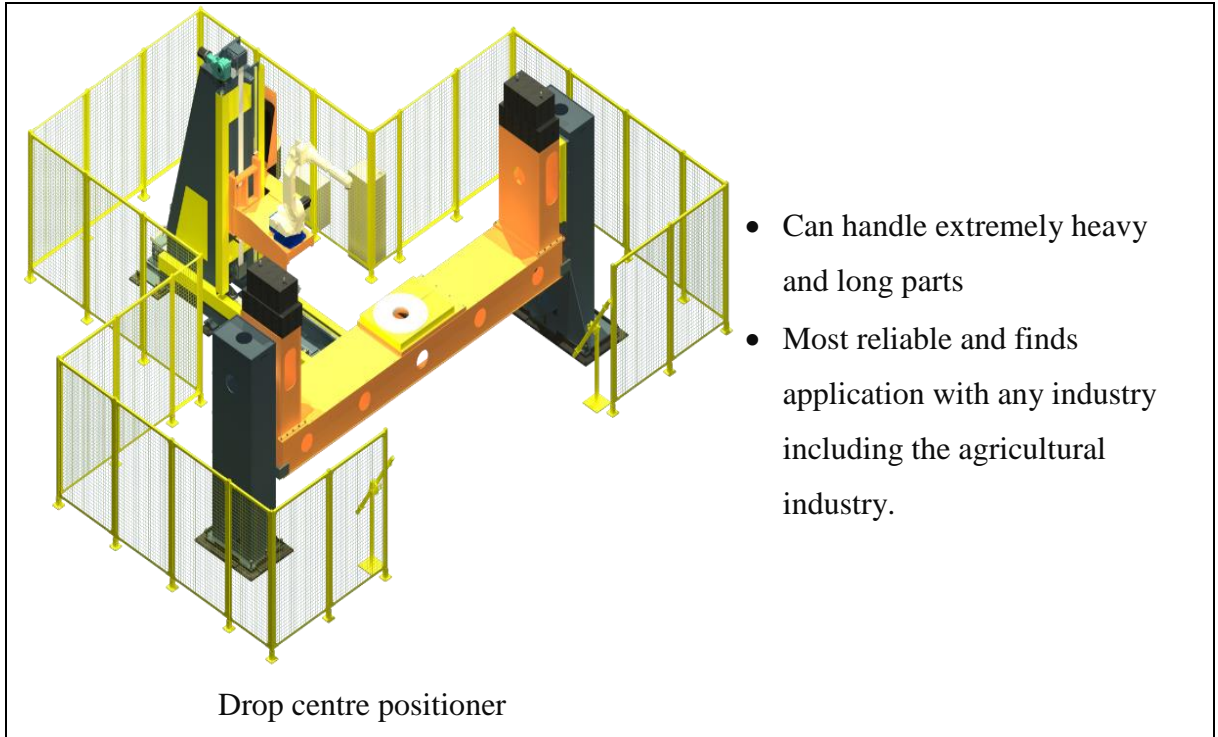
Table 10: Various sensors used for obtaining information from the weld pool (Zhang, 2008).

Sensor type	Sensors used for monitoring	
Contact type sensors	Contact probes	Micro-switches, potentiometers, differential Transformers
	Electrode Contact	Voltage and current for contact detection applied to the tungsten electrode or welding wire
	Temperature	Thermocouples, thermistors
Non-contact type sensors	Temperature	Photo-thermometers, infrared thermometers
	Arc phenomena	Welding current, arc voltage, wire feed rate, number of short circuits, number of peak current anomalies
	Laser vision	Point sensors, linear sensors, area sensors
	Electromagnetic	Induction coil
	Sound	Detection of sound pressure or ultrasonic sound pressure

4.2.1 Welding as a Complex Process

Welding process is a complex system which generates “outputs” i.e. properties of the weld from “inputs” i.e. adjustable welding parameters. The outputs are affected by parameters that can be adjusted on purpose to control the outputs and are therefore called as control variables. Some parameters which does not vary during welding are called welding conditions and are therefore constant. Fluctuation or variation from the nominal constant values can occur and affect the outputs, but the changes are not intentional. These fluctuations are the disturbances. Therefore welding is a complex process which has multiple inputs, multiple outputs, and multiple disturbances. Artificially decomposing the design of a complex welding system converts the complex systems into few simpler systems. Figure 20 shows the artificial decomposition of complex system for effective monitoring and control. In-order to produce the desired outputs, all the disturbances must be avoided or minimized and the welding conditions must be maintained at nominal constants. Hence monitoring of all the major welding parameters and welding condition that may change or have deviations from their nominal constants is required and monitoring of the disturbances, inputs, and outputs of each sub-process. (Zhang, 2008)

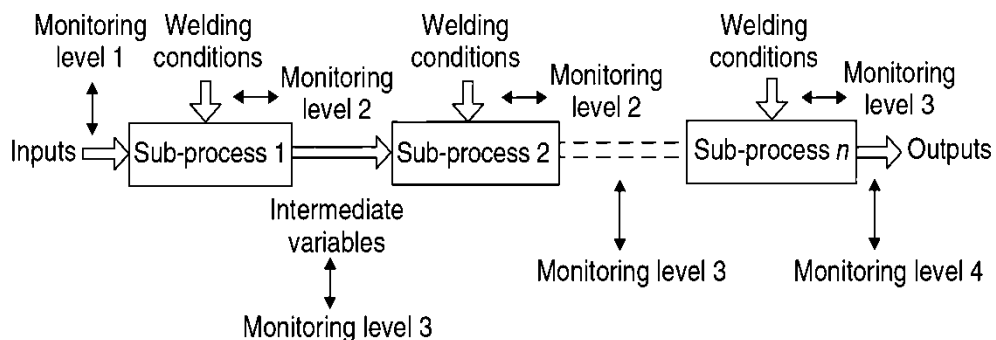

Figure 20: Illustration of artificial decomposition of complex system for effective monitoring and control (Zhang, 2008).

Frequently changing welding conditions, for instance, the pre-machining errors, variation in gap size and position rising from the inappropriate work-piece fitting, distortion in positioning due to heat transfer in workpiece, are some of the common scenarios in practical fabrication units. Advanced electronic control and employment of special algorithms specifically to improve the control, significantly helps in achieving quality weld in real time. More control over the welding process results in a cooler welding process, which causes

less distortion, improved bridging of gaps and less spatter. Moreover, manufacturing of some large components requires flexibility from the welding equipment as these large components are difficult to be handled. Therefore developing an intelligent welding system that can adapt to a dynamic welding environment is necessary in improving the effectiveness of the current teaching and playback type robotic systems. (Chen, 2007; Chen, et al., 2010; Fenglin, et al., 2010)

4.2.2 Weld Data Sensing

In-order to understand and control the complex welding process, accurate measurement and observation of weld pool is necessary. Human welders rely heavily on weld pool surface, which is the direct source of information to get the feedback from. Professional welders develop the skill of visually observing the weld pool to make appropriate changes in the weld parameters (Ma & Zhang, 2011). There are several aspects such as the weld seam, weld profile, weld penetration and weld pool surface that needs to be monitored during the welding process to effectively adjust the welding parameters. Table 11, Table 12, Table 13, Table 14 shows the different techniques used in monitoring the aspects such as the weld seam, weld profile, weld penetration and weld pool surface.

Table 11: *Different techniques used in weld monitoring systems (1/4).* (Zhang, 2008; Na, 2008; Ma & Zhang, 2011; Zhang, et al., 2012)

Aspect Monitored	Necessity for monitoring the aspect	Ways to perform the function	Description
Weld Seam Monitoring	<p>Conventional robots are limited by the changing weld conditions such as the pre-machining errors, variation in gap size and change in position due to inappropriate work-piece fitting, distortion in positioning due to heat transfer in workpiece. Dimensional variations are introduced by pressing tools, fixtures, and thermal distortions during welding. Therefore, it is necessary to introduce an automatic monitoring system that observes or tracks the changes in the actual location and orientation of the welding line and its detailed surface geometry.</p>	<p>Through-Arc monitoring</p>	<p>The arc sensor eliminates the use of separate detectors around the welding torch, and can detect the groove position directly or provide the information on the surface position of molten pool almost in real time. The basic principle involved in through-arc monitoring is the change in the current in response to the variation of tip-to-workpiece distance. The power source has flat or constant voltage characteristics i.e. the welding current shows an almost linear relationship with the tip-to-workpiece distance. Therefore any variation in the tip-to-workpiece distance will have a consequent change in the welding current. Required weld joint geometry can be obtained by weaving the welding arc transversely across the line of travel in V-groove butt welding or horizontal fillet welding.</p>
		<p>Electromagnetic monitoring</p>	<p>The electromagnetic sensor which consists of several coils used for detection of mechanical variables such as position or displacement are fastened around a core construction. The sensor can be placed around the welding torch.</p>
		<p>Laser visual monitoring</p>	<p>The laser visual monitoring method uses either a structured beam or a scanning beam to be projected over workpiece to effectively track the changes in position or any potential deformations of the workpiece. The active vision sensor uses the optical triangulation method to track the variations in the position.</p>

Table 12: Different techniques used in weld monitoring system (2/4) (Zhang, 2008; Na, 2008; Ma & Zhang, 2011; Zhang, et al., 2012).

Aspect Monitored	Necessity for monitoring the aspect		Ways to perform the function	Description
Weld profile monitoring	For assessment of weld surface shaping defects	Crater cracks, cracks, humps, bad shaping, cavities, undercuts and misalignments are some of the weld surface shaping defects. These defects have very distinct geometric features that can be captured and identified from the weld bead appearance.	Structured light detection	Structured light detection is an active visual method that uses a point light of a low-power laser to be projected over the diffuse surface, which in turn produces an image on the surface of a light-sensitive sensor (high resolution camera). The obtained frames of images are then plotted for the light intensity variations. Any displacement of the diffuse surface, in a direction parallel to the laser light will correspondingly create variations in intensity of the light at that location. Thus, according to the variations in the intensity of the imaging plane, the position of the diffuse surface can be determined. Reflection-based weld pool monitoring methods, which take advantage of the specular nature of the weld pool surface, successfully reduced arc light interference.
	For assessment of weld penetration	The performance and strength of a welded structures heavily relies on the penetration of the weld, therefore effective control over the penetration depth is important. The backside width of a weld is the most direct physical parameter reflecting weld penetration. Backside width can be effectively predicted by monitoring the topside shaping parameter. This method needs to detect appropriate on-line topside geometric feature parameters of the weld, and then a relation model is drawn between the topside geometric feature parameters and the backside width.		
	For assessment of shaping parameters	The inspection of weld quality requires the weld profile dimensions to satisfy some special requirements in view of its relationship with weld strength and weld joint mechanical properties.		

Table 13: *Different techniques used in weld monitoring systems (3/4)* (Zhang, 2008; Na, 2008; Ma & Zhang, 2011; Zhang, et al., 2012).

Aspect Monitored	Necessity for monitoring the aspect	Ways to perform the function	Description
Weld Penetration monitoring	Sensing and control of weld joint penetration is a fundamental issue in automated welding. Important metal joining applications typically require that the weld pool reach the bottom side of the work piece to produce full penetration. When the backside width is large enough, liquid metal could drop from the weld pool as it lacks the support from solid metal. Therefore it is necessary to measure the backside width of the weld pool, to control and maintain the depth at a desired level or at least above a minimal value.	Pool Oscillations	Uses the pool oscillation frequency to detect the penetration mode (partial or full penetration)
		Weld pool shape	Utilizes the front side of the weld pool shape to estimate the backside width of the weld pool
		Sag depression pool shape	Estimates the backside width of the weld pool based on the depression of the weld pool
		Intrinsic plasma charge	Extracts weld penetration information from the weld arc
		Infrared measurements	Measures front surface's temperature distribution to estimate the weld pool depth
		Ultrasonic Measurements	Detects the weld pool depth based on received ultrasonic signals

Table 14: *Different techniques used in weld monitoring systems (4/4)* (Zhang, 2008; Na, 2008; Ma & Zhang, 2011; Zhang, et al., 2012).

Aspect Monitored	Necessity for monitoring the aspect	Ways to perform the function	Description
Weld Pool surface monitoring	<p>The weld pool surface is the most direct source of information for human welders to obtain feedback.</p> <p>The influence of pool surface deformation on the arc energy distribution, and its correlation with possible weld defects and with the weld penetration makes it one of the important aspects to be monitored during the welding process. The weld pool surface geometry information such as the boundary and deformation are essential in realizing better quality welds and penetration.</p>	Vision based sensing	<p>Early efforts focused on extracting a two-dimensional weld pool boundary by directly viewing the scene under the welding gun. In recent years, weld pool observation evolved from two-dimensional (2-D) boundary extraction to three-dimensional. Vision sensors attached to and moving with the welding torch to conduct front side sensing of the weld pool surface have been developed and used in a number of applications. The weld pool surface has a 3D profile, which consists of a 2D pool surface boundary and 3D pool surface deformation.</p>

4.2.3 Weld Data Management

In the past, raw data from the arc was provided to the user, effective usage of these data to improve the weld performance were based on the interpretation skills of the users. Therefore huge amount of data were generated from the weld monitoring systems, however lacked the resources to convert these obtained data into actionable information. Since then significant research have been focused on methods to improve the decision-making process based on the information extracted from the monitoring systems, to increase productivity, improve quality and lower the operating costs. Evolution of the database technology promotes bridging of the gap between data and information. Weld data monitoring capabilities, when directly embedded into the power sources allows simplified deployment and management and supports easy interpretation and use of the collected data. More advanced systems capable of delivering information to not only plant management, but also to operators, welding engineers, maintenance personnel, and others. (Campbell, et al., 2012)

Fully integrated and third-party solutions of the weld data monitoring systems are available for fabrication and manufacturing companies, depending upon their requirement. Fully integrated power source systems offer built-in solutions that supports seamless integration and minimal startup time. However companies with already established power source fleets without the built-in solution options, can utilize the third-party systems. Data from the welding machine are transferred to the computer using Ethernet or Wi-Fi networks. Co-existence of all the welding machines and the computer on the network supports many within the organization to access the information at any time and in a simplified manner. (Campbell, et al., 2012) Table 15 shows the most important usages of weld data monitoring in the industries.

Non-value added costs and labor increases invariably, the welding quality issues. The root causes for a number of quality-related issues can be identified and solutions for the problem can also be obtained through the weld data monitoring systems. A human/machine interface in the weld cells gives instruction for the operator to complete the fabrication of the component in sequence. The beginning and completion of the work is reported by the operator to the system. Then the system checks the weld count against the expected weld count and desired welding parameters against the actual weld parameters. As the most effective way to avoid a recurring weld defect is by sensing its cause in real time, the system

monitors the key variables, such as voltage, current, wire feed speed, gas consumption, and duration and compares them to predetermined upper and lower limits for each weld. Then the system alerts the operator about the failed weld for further inspection and additional solutions. Similarly minimum and maximum duration limits are set within the system to avoid under and over welding. Welding engineers, in-order to promote structural integrity and to control heat input and potential distortion can suggest the part to be welded in a specific sequence. (Campbell, et al., 2012)

Weld data monitoring systems could effectively track the productivity of the welding system. Information such as the total number of welds made and total parts welded, percentage of downtime compared to arc-on time, and deposition rates are collected to provide detailed performance reports on each of the user's weld cells. Comparison on similar weld cells could provide reasons for inefficiencies in certain cells. These information empowers the companies to take a closer look at the particular cells or the station to determine the underlying problem. Similarly weld data also provides an effective path in validating the simulation/numerical models, which helps engineers to analyse and evaluate the welding process. (Campbell, et al., 2012)

Table 15: Common usage of the interpreted data from the weld monitoring systems (Todd, 2012).

Real-Time Weld/Arc Monitoring	In real-time weld/arc monitoring, the defined values of the information such as the voltage, wire speed, gas flow and current are compared to the upper and lower limits. Then results of this comparison are communicated.
Weld Data Acquisition	In weld data acquisition, the defined variables are measured, displayed and stored to evaluate the specific arc characteristics.
Production Data	Information for gauging productivity can be obtained through production data. Productivity related information such as the overall equipment effectiveness (OEE), downtime, arc-on time, and total parts made, as well as performance factors such as deposition rates, wire use, gas use, and weld faults can be used to obtain the overall picture of the system.

4.3 Future Trends in Intelligent Welding Systems

Humans have mastered the art of welding for decades. Hence in-order to produce a quality weld, the experience-based behaviour and skills of a human welder is very important. Next generation intelligent welding machines are currently being researched which has the ability to learn human welder's behaviour and train welders faster. The mechanized welding can never match the performance based on the response from the versatile sensory capabilities of a skilled and experienced human welder. However daily operations by a human welder may lead to inconsistent concentration, fatigue and stress which have serious impact on the weld performed which is not the case of mechanized welding. (Liu, et al., 2014) Figure 21 shows the processes involved in human welder's behaviour. Figure 22 shows the process involved in intelligent welding machine that replicates human welder's behaviour.

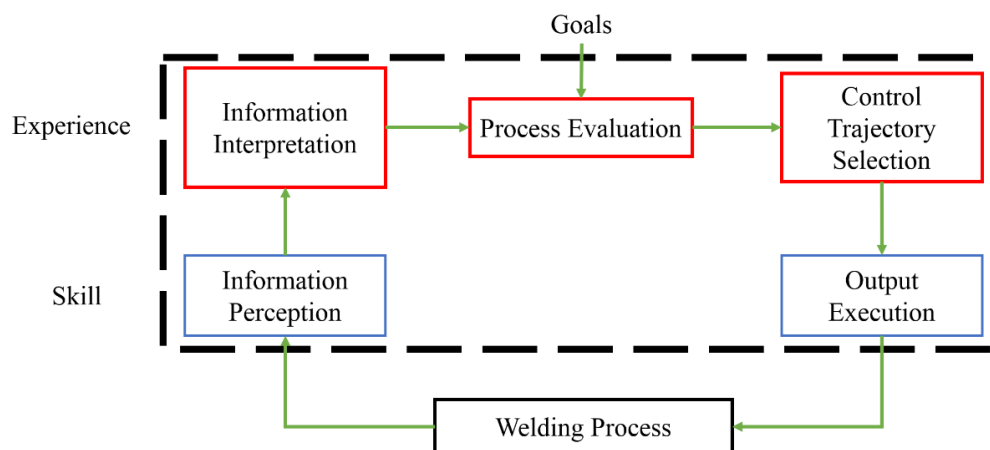

Figure 21: Illustration of the processes involved in human welder's behaviour (Zhang & Zhang, 2012).

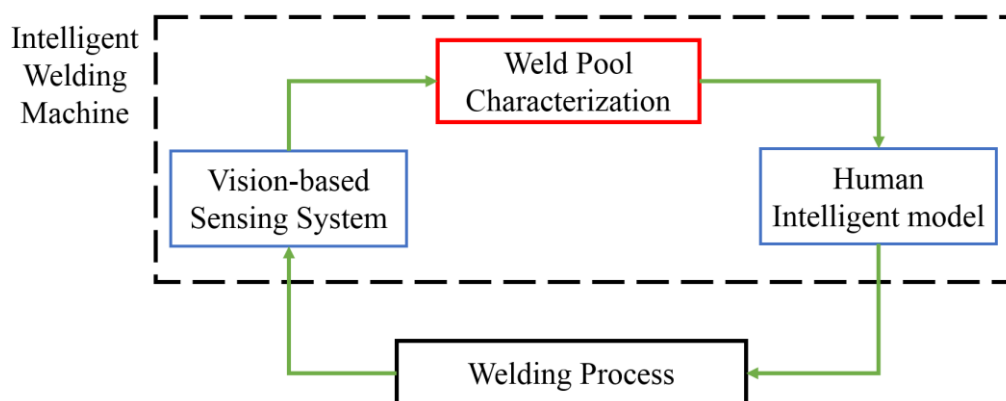

Figure 22: Illustration of intelligent welding machine that replicates human welder's behaviour (Liu, et al., 2014).

Three basic steps are quite necessary for developing an intelligent welding system to imitate a human welder. Firstly, the welding system should be able to sense and extract the critical information from the real time dynamic weld process. Secondly the welding system should be able to identify the behaviour or the characteristics of the dynamic weld pool i.e. modelling of weld process. Finally the intelligent system should have necessary capability like the human brain to make decision and take control of the welding process based on the extracted information. Therefore to develop an intelligent robotic welding system, the challenges behind combining the human welder's intelligence and physical capabilities of the mechanized machines needs to be explored and adopted (Zhang & Zhang, 2012; Liu, et al., 2014)

5 WELDING SAFETY MEASURES CONTRIBUTION TOWARDS GREEN MANUFACTURING

Safety in the industrial sector will continue to play an important role as companies focus efforts on keeping safety records spotless. Welding is one of the most demanding process, in all manufacturing and fabrication industries. However it is the most significant source of toxic fumes and gas emissions. Welding fumes and gaseous hazards are still, significant problems in manufacturing industries in spite of the tremendous advancements in the welding control and automation technology. Worldwide industries consume an estimated one million tons of weld metal annually, which means an estimated 5 thousand tons of fumes are generated annually with an average fume production rate of 0.5% of weld metal. Although welding process has significantly been automated and mechanized in the manufacturing units, the number of welders exposed to weld related hazards constantly increase. Worldwide, around 3 million personnel with different professional background directly encounter the welding fumes and other weld hazards. Implementing a safe working environment benefits the companies on the long run from reduced insurance bills and employee longevity. A safe work culture should be developed where effective safety practices are promoted. Process developments which improve the conditions of the working environment and substitute the welder from hazardous operations are recommended to ensure safe working environment. (Olivera, et al., 2014) Welding related safety hazards are listed in Table 16.

Table 16: Common Weld Safety Hazards (Cary & Helzer, 2005).

Hazard	Processes
Electric Shock	Arc, resistance electron beam
Toxic gases(e.g. Ozone)	Arc Processes
High Pressure and asphyxiant gases	Most welding and cutting processes
Flammable and explosive gases	Oxy fuel Processes, Plasma cutting
Radiation, Visible, IR, UV	MMA, TIG, MIG, Plasma, Laser
Ionising Radiation (X-Rays)	Electron Beam
Particulate fume	Arc and Power beam processes
Noise	Friction, Plasma

Electric Shock is a common risk in the machine shop where proper insulation of the operator and proper grounding of the equipment is not carried out effectively. The most common instance is when the operator initiates the weld using the high-frequency option. The continuous use of high frequency option can become unstable when welding in alternating current. The instability in the arc occurs when the current switches from positive to negative and the high-frequency option helps the welding current to bridge gaps in an effort to close the welding circuit. This becomes a serious hazard to the operator if he/she is not properly insulated from the welding system. Permanent hearing loss and general fatigue can result from the effects of noise in almost any manufacturing shop. Welding process which involves an annoying buzzing sound for example loud noise could be heard with AC-GTAW. Additional process including the weld preparation activities such as Cutting and beveling can also result in a significant amount of noise. Elevated noise levels should be curbed effectively as it could lead to fatigue of workers. Fatigue can result in at-risk behavior and injuries in other areas of the job site. (Thomas, 2013)

5.1 Fume Formation Mechanism

Welding is performed by high temperature heating and evaporation of base metals and electrodes in-order to be coalesced together. During welding, fumes are formed as a result of condensation of the gas and vapor mixtures (Voitkevich, 1995). During welding, gaseous and aerosol by-products composed of a complex array of metals, metal oxides, and other chemical species volatilized from either the base metal, the welding electrode, or the flux material are produced. Therefore welding fumes are metal-containing aerosols consisting of particles formed through complex vaporization– condensation–oxidation processes during welding. When the vaporized metal rapidly condenses in air, fumes are formed and these are too small to be seen by the naked eye but can be identified as a collective visible plume. Welding processes generates sub-micrometer sized aerosols, and research has indicated sub-micrometer aerosols may cause adverse health effects due to their size. For Example during the welding process, fume are generated which contain very small metal oxide particles. These particles are small enough to become and remain airborne and are easily inhaled. Similarly welding fumes produce particles which have a high probability of being deposited in the alveolar regions of the lungs and their sizes range from nanometer scale to hundreds of micrometers. The also contain heavy metals, such as chromium, manganese, and nickel, which cause respiratory diseases and cancer. The magnitude of the hazard created by

welding fumes depends on the composition and concentration of the fumes and gases and on the exposure time. (Antonini, et al., 2007; Srinivasan & Balasubramanian, 2011; Yu, et al., 2011)

The Fume Formation Rate (FFR) is used to specify the relative cleanliness of the welding process. Occupational hygienists and manufacturers are interested in the prediction of fume formation rate during metal arc welding and the composition of the fumes for the assessment of risks in the welding products delivered. Welding method is one of the main factors that affect the fume generation rate, also the welding procedures, the chemical composition of the shielding gases, the filler and the base material, the presence of coatings and the time and severity of the exposure significantly influence the fume generation rate. Changes in process parameters and many other factors influence the FFR and the fume composition. With increasing productivity, amount of fumes generated during welding increases. Any material is a potential source of fume when heated to a high temperature. Isolating the individual effects of each factor is very difficult, as most of them are somehow interrelated. Methods for reducing FFR and the concentration of hazardous metals in the evolved fume have been investigated citing concerns of their potential health effects. (Hewitt, 1994)

Welding procedure, Shielding gas chemical composition, filler metal and base material, presence of coatings, time and severity of exposure and ventilation are the factors which significantly influence the chemical composition of the particles (Pires, et al., 2007). The fume released during GMAW is the result of three main sources which includes the molten droplets at the tip of the electrode and falling through the arc (in dip mode the wire tip melts but free droplets are not formed), the weld pool and the spatter (Dennis, et al., 2001). In GMAW process, increasing welding current increases heat input thereby increasing welding temperature and weld metal deposition thus increase FFR. Generally in GMAW process, the fume particles generated are from the electrode materials and accounts for 80% to 90% of the total metal content of the fume. Fumes contains particulates of condensed metal vapor which vaporize during welding. The particulate matter from the fume depends on the composition of the electrode and commonly includes Fe, Mn, Si, Ni, Cr and Cu (Peter & Andrew, 1997). In GMAW process, the amount fumes generated from spatter accounted for 35 % in the experiment by Gary (1980) and the experiment also indicated that the

workpiece makes a minor contribution to the fume formation. Similarly observations by Dennis and Mortazavi (1996) found 6–14% fume were accounted from the spatter produced.

In most cases, droplets were major sources of the fumes in the globular and spray type welding modes. Generally dip mode occurs at low currents and spray at high currents with globular occurring between dip and spray modes. The fume formation rates for dip mode are generally lower than for the spray type mode. Rupture of the narrow neck during the dip mode can result in production of micro-meter sized particles and thereby form fumes. (Dennis, et al., 2001) Figure 23 shows the evolution of fume formation rate with the current intensity. The Figure 23 indicates an increase in the FFR with the corresponding rise in the current intensity. However, this increase is not linear, due to the different arc welding behaviors (Pires, et al., 2007).

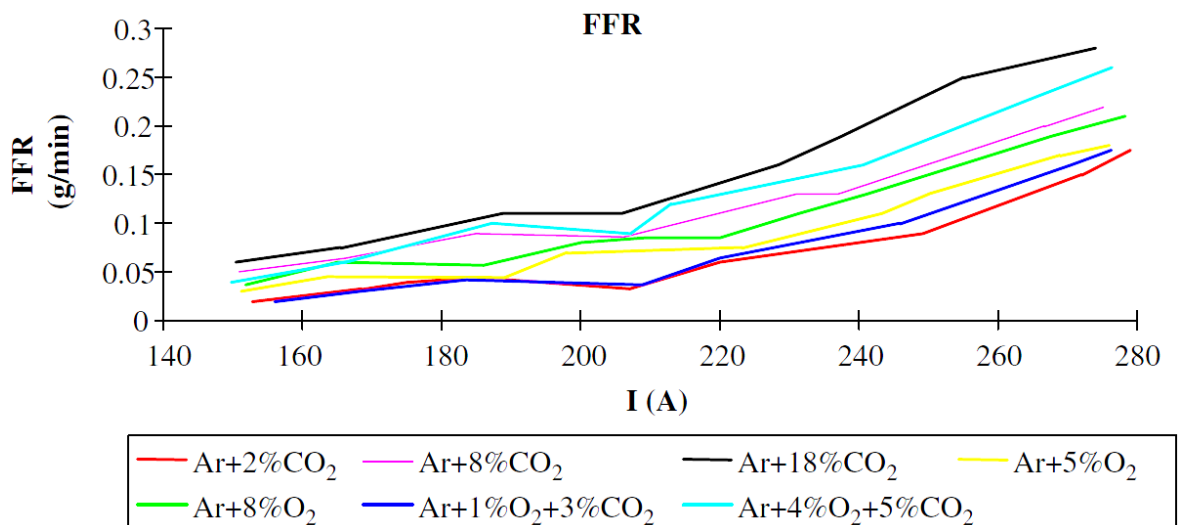

Figure 23: Variation of fume formation rate (FFR) with the current intensity for GMAW process with different gas shielding mixtures studied (Pires, et al., 2007).

5.2 Fume Emission Control

Safety regulatory bodies such as Occupational Safety and Health Administration (OSHA) and other bodies have developed new standards to help protect employees against potential health hazards in the workplace. These regulations, which dictate allowable exposure limits of welding fumes and other particulates have made it obligatory for companies to adopt various safety measures that include installation of the fume extraction equipment. OSHA's concern is to restrict the fumes and toxic chemicals from reaching the breathing zone of the

workers and also to ensure that the contaminants in the air are below established limits. Regulatory compliance is not the only reason for companies to invest in the safety equipment and structures. When the working environment is clean and safe, the workers are healthier and productive. They experience less illness and take less medical absence. The companies also gain from employee longevity. A clean machine shop can reduce the buildup of nuisance dust on electrical control panels, circuit boards. Companies build up trust with the customer and employee by maintaining an optimal welding operator safety.

Finding efficient controls to decrease the toxicity of heavy metals evaporated from the welding process is the most direct way to protect workers. The reduction of fume emissions at source is of extreme importance since the effective control of fumes emitted during welding, through general and local extraction, is not always adequate. Significant research have been promoted on finding ways to reduce the FFR and toxic concentrations in the evolved fume. Various solutions have been investigated based on the welding process to lower the emission of welding gases and fumes or to reduce physical demands. For example using “green” consumables with special coatings in combination with more effective shielding gases, reduces the droplet temperature during GMAW welding. Although manipulating the composition of shielding gas can decrease fume formation rate, it does not significantly affect the fine particle fraction in the welding fume. The reduction of weld fume is essential in improving the shop floor conditions that involves a technological and complex problem of controlling the fume emissions at the source. Control of fume at the source, by modification of procedures and/or consumables, can be used to complement the existing control strategies. Therefore, it is necessary to study the influence of welding parameters on the fumes released, in order to identify the effective parameter that could control the emission of the fumes generated. The process parameter optimization method offers a systematic approach to fume emission control and to support the decision making process on ways of promoting a healthier environment for the welders. (Knoll & Moons, 1999; Srinivasan & Balasubramanian, 2011)

The head is the body’s command center and no other part of the human body affects, more than the head, on how we do our job or how we feel about it. Therefore the safety equipment manufacturers have invested on designing products that not only keeps the welder safe but also provides enough comfort while performing the job. Occupational Safety and Health

Administration (OSHA) enforces the use of personal protective equipment (PPE) to reduce employee exposure to hazards where effective implementation of engineering and administrative controls to reduce the exposures are not feasible. It is important for welders that they pay attention to their surroundings, follow safety procedures and wear PPE's at all times. Some companies may adopt centralized fume extraction systems which has the capacity to collect fumes from the entire shop area. Although these systems are very effective in fume collection, they require installation of new ductwork and fans to remove fumes and are also more expensive than other systems and may not be the right choice for every company. (Gardner & Sommers, 2011; Dan, 2013)

5.2.1 Integral Fume Extraction Torches

In-order to ensure the welder's comfort and safety, the use of integral fume extraction torches are essential. Fume extraction guns (as shown in Figure 24) operate by capturing the fume generated by the welding process right at the source, over and around the weld pool. These devices incorporate fume extraction capability within the handheld welding tool thereby reducing the installation on local exhaust equipment or the use of personal protective equipment (PPE). The unnecessary transportation and repositioning of the extraction equipment is avoided in this method. With introduction of the light and sleek integral fume extraction torches, the flexibility and mobility of the system has increased. (Greg, 2012; Dan, 2013)



Figure 24: Fume extraction torch restrict the reach of fumes to the welders (Deanna, 2015).

Application include the shipbuilding and heavy equipment manufacturing industries, as well as general manufacturing and fabrication. Source capture systems are popular for applications using solid wires and particularly for confined spaces. One distinct advantage to fume extraction guns is that they remove the fumes at the source, minimizing the amount that enters the welding operator's immediate breathing zone. However, because welding

operators typically move the gun away from the weld pool after completing a pass, the fume extraction gun is not as able to control residual fume as well as a fume extraction hood can. The fume extraction gun requires to allow appropriate amount of shielding gas without losing its capacity to capture the weld fumes enough to protect the welding operator. The balance allows the weld pool time to react and solidify, and gives the fume particles time to decelerate so they are easier to extract. (Greg, 2012; Dan, 2013)

5.2.2 Exhaust Ventilations Systems

The main purpose of the exhaust ventilation system is to reduce or preferably avoid exposure of the workers to contaminants. The exhaust ventilation system can remove the toxic gases and the fumes at or near the emission source, thereby minimizing the opportunity for contaminants to enter the workplace air. They typically use a flexible source-capture arm or a complete enclosure around the operation, such as a glass enclosure around a robotic weld cell. This approach is usually limited to smaller work areas. Figure 25 shows a mobile low vacuum unit with extendable arm for increased flexibility.



Figure 25: The low vacuum/high volume mobile unit has an extendable arm for easier positioning (Miller Welds, 2015).

Modular extraction hoods (as shown in Figure 26) are often utilized for medium size workspace. Curtains or hard walls are added to create a booth or enclosure and prevent gases

from escaping to the workshop. Modular extraction hoods for both automated welding and manual welding are becoming very popular. Figure 26 shows the modular extraction hood with filtration system for gas reusability. However the welders are still required to use PPE's while working inside the modular hoods. Ambient systems use a central collector or a number of smaller collectors to filter all the air in the shop. An ambient system is more practical to control fumes in a facility with multiple operations. Various welding processes, large parts, and stitch welding are examples of operations that are well suited to ambient collection. Cartridge dust and fume collection systems help to avoid respiratory and health problem by keeping the contamination level of the air within the regulatory requirements. These systems have cartridge filters that effectively collects the visible emissions and will, in many cases, be the solution of choice. Cartridge filtration is identified in the regulation as an acceptable control device to eliminate visible emissions. Such a system will properly filter welding fumes and other hazardous contaminants, and the cleaned air can be recirculated back into the facility or exhausted outside. These systems use self-cleaning mechanisms that pulse dust off the filters, allowing the units to run for extended periods between filter change-outs. (Greg, 2012)



Figure 26: The modular extraction hood with attached filtration unit for gas reusability (Millerwelds, 2015).

5.2.3 Personal Protective Equipment

5.2.3.1 Safety Glasses

Unfortunately, despite regulations, it is common to find welders not wearing safety glasses underneath their welding hoods. Radiated light is a potential hazard where the arc from the welding process produces three types of light: ultraviolet, visible and infrared. Ultraviolet light, which is invisible to the human eye can cause temporary inconvenience such as the sunburns, however continued exposure can lead to serious health issues like melanoma and cancer. Therefore manual welding operators require long sleeves and pants. Visible light can easily be avoided however can cause potential eye problems such as blindness. Light-blocking curtains are a great way to protect those who may not be dressed for welding. Arc flash can cause severe sunburn on one's eye and also affect someone who is nearby. As human eye is one of the most sensitive part of the body utmost care is required to protect it from unsuspecting dangers in the welding process. Therefore, the welder and the person nearby are potential victims of eye damage if basic safety measures such as wearing a polycarbonate safety glasses that will block the majority of the ultraviolet light rays produced by welding are not taken into considerations. Many believe them to be redundant to the welding helmet or too cumbersome to wear in conjunction with a helmet. While modern welding helmets do a decent job of preventing hazards from reaching the eyes, there is still no substitute for primary eye protection such as a pair of safety glasses. (Thomas, 2013)

5.2.3.2 Auto-darkening Welding Helmets

Recently the electromagnetic detection of the weld has been introduced to the auto-darkening helmet technology. In the past, welding helmets used the optical sensors to pick up the light, however now the magnetic sensors pick up on the magnetic field of the arc, to respond more consistently and protect the welder's sight. It especially improves performance when welding outside on sunny days. The auto darkening feature allows the helmet to only darken, if the arc is struck, regardless of sunlight. This substantially improves detection when welding outside and eliminates the issues, related to traditional welding helmets. (Thomas, 2013)

5.2.3.3 Powered Air Purifying Respirators

Today welders are protected with powered air-purifying respirators (PAPR) as introduction of recent hexavalent chromium standards has driven many manufacturers and fabricators who handle stainless steel to install these systems. The PAPR (as shown in Figure 27) helps keep the welder's face clean and comfortable. The less intrusive nature of the powered air-purifying respirators, with substantial reduction in battery weight and evenly distributed light-weight systems have attracted companies adopt to these systems.



Figure 27: The powered air-purifying respirator contains hard case helmet with air purifying unit (Miller, 2015).

The contaminated air from a blower passes through a high-efficiency particulate air filter where its contaminants are removed and purified air is supplied through a sealed welding helmet. As the influence of the operator comfort is important for a productive work output, cool air flows through the welder's face similar to heat stress relief products, making the work experience more appealing (Thomas, 2013).

6 PERSONNEL TRAINING CONTRIBUTION TOWARDS GREEN MANUFACTURING

Welding is possibly the most complex manufacturing process and may be the least understood. This has led to a shortage of educated employees in this field. Manufacturing remain a critical sector of the world economy. Welding whether it is performed as production welding on new parts and subassemblies, used to maintain existing equipment or used in construction projects such as pipeline or infrastructure- is a critical and valued manufacturing process. The number of welding professionals needed, including welder, welding technician, welding supervisors, and welding engineers, remain a moving target. The well-educated and trained personnel can understand the welding related principles and avoid mistakes in the welding process resulting in reduced material and energy loss and improved productivity. Welding educators need to employ the most effective and efficient education methods to ensure a steady supply of welding professionals. The focus should not be on return to traditional blue collar and manufacturing jobs, but to reinvented manufacturing enterprise and revitalized manufacturing jobs through innovations reorganization and education. Welding education and often all technical education should follow the lead of modern manufacturing and incorporate the newest innovation in both welding technology and education technology into courses at all levels. The use of information technology systems provide an unbounded opportunity for educators in all discipline to help their students know more, find more and practice more, both guided by the teacher and independently. The ability to instantly retrieve knowledge and information on any subject allows, teacher to challenge their students to achieve at unprecedented levels (Bill, 2014).

For welding jobs requiring technical skills, proof of course completion or certification is required. But for welding skill jobs, a performance test is likely required online experience and virtual welding experience does not give the prospective employee the actual under-the-hood experience needed to be successful when completing an entry –level employment test or qualification test. Although virtual welding can help a welding student verify the angles, hand positions, and travel speed, virtual welding cannot not be a substitute for guided practice and the subtle changes in technique, an experienced teacher can suggest. In most

developed countries, organizations have been created to support the ever-growing utilization of welding technologies. As a result of the growing integration of countries into the European Union, organizations that would provide international support for national members have been created. One such organization is the European Welding Federation (EWF), a leading institution driving the qualification and certification of professionals and companies. The EWF counts as its member the Welding Institutes of Europe, which were at its inception looking for opportunities to harmonize the way qualification of personnel in welding technology was achieved in different countries. (Bill, 2014; Luisa, 2014)

7 CONCLUSIONS AND DISCUSSIONS

Energy efficiency has become top priority of national and international policies. Excessive energy consumption in the past has resulted in significant rise in CO₂ levels and thus major climate changes. Manufacturing industries are also more concerned with energy consumption due to the rise in energy cost. In these continuously changing economic times, manufacturers are on a constant quest for finding ways to optimize and streamline welding operations in an ecological and efficient manner. Effective solutions for this end result can only be achieved with continuous changes to the welding operations.

In recent years, welding processes have significantly benefited from the new technological advancement in the electronic industries. With the help of advancement in inverter technology, accurate manipulation of the voltage and current has resulted in better control of the arc and the transfer of weld metal. The inverter power supplies using transistor technology have very good energy conversion rates and provide faster response times and higher pulse frequencies when compared to the old transformer/rectifier power supplies. Working at higher frequencies enable smaller and more efficient magnetic components to be used which in turn requires less electrical power and reduce overall energy use in the industries. The high processing power of the welding units performs complex algorithms based on the feedback obtained and can predict the minor disturbances in the arc and out-react them at very high speeds. The power sources can deliver power to the arc in any form the operator deems appropriate. The advanced feedback control unit influences the welding parameters throughout the process to secure a good welding quality. With the help of intense research work on this field, the application scope of the advanced power supplies have been appreciably broadened. Therefore, the weld production efficiency and the weld quality can be tremendously improved in the manufacturing industries by adopting the smart power source systems.

Since the introduction of GMAW systems, researchers have focused on improving its performance which has increased its efficiency and has considerably widened its applicability. P-GMAW process, a recognized and accepted technology for efficient welding, can weld better on thin materials, control weld distortions and run at lower wire feed speeds. P-GMAW is a modified spray transfer process that provides the best of both

short-circuiting and spray transfer, by using a low base current to maintain the arc and a high peak current to melt the electrode wire and detach the droplet. DP-GMAW has wider adjusting range of parameters than P-GMAW which helps achieving higher productivity without quality drops. CMT which differs from the traditional GMAW process relies on low level current (during the short circuit phase) and the perfectly controlled wire retraction movement for material transfer. In CMT welding, the substantial reduction in heat input results in a cooler weld that has very little workpiece strain, limited structural distortion and low dilution of base alloys. CMT can also perform high-precision welds on dissimilar metal joints and very thin metal sheets. Significant improvement in the deposition rate without increasing the heat input, or a balanced heat input and deposition rate can be obtained with DE-GMAW as desired by operator. Challenges in conventional GMAW such as the fixed correlation of the heat input with the deposition can now be improved with DE-GMAW. The main advantage of T-GMAW is its flexibility in addition to increased weld speed, less spatter and very high deposition rates. The AC-GMAW combines the advantage of arc stability from the DCEP region with that of the high melting rate from the DCEN region to secure good weld quality. The cleaning action of AC helps to reduce the black soot-like oxide particles on the surface of the aluminium alloys. The AC-GMAW is well known for its improved distortion control, reduced heat input, higher melting rate of welding wire at a given power level and reduced dilution.

State-of-the-art friction-stir-welding will continue to be a critical technology as we continue to learn how to build more efficient space vehicles with less expensive materials. FSW is regarded as a green technology because of its energy efficiency, environment friendliness and versatility. It also increases efficiency by reducing the number of weld passes that traditional fusion arc welding requires. In addition, it offers safer, more environmentally friendly operations than traditional welding by not creating hazards such as welding fumes, radiation or high voltage. Laser assisted friction stir welding minimizes the need for strong clamping fixtures, force required for plasticizing the material, wear rate of the tool pin. FSSW offers greater alloy joining flexibility, significantly reduces energy consumption, lesser peripheral equipment, lower operational cost and lower weld distortion than Resistance Spot Welding (RSW) and has therefore been considered as a potential alternative for RSW and clinching, to fasten two metallic work pieces. Significant reduction in capital cost of up to 50% can be realized when compared to RSW. RDR-FSW supports very low

welding loads and improved weld quality. The total torque exerted on the workpiece by the tool and the overheating problems are reduced by this process. The peculiarity about this process is that the tool pin and the assisted shoulder are independent and so they can rotate reversely and independently during welding process.

Narrower weld seams, higher tensile strength, deeper penetration, lower thermal input and higher welding speed could be obtained with HLAW when compared to GMAW process. Their high efficiency, high beam quality, and low operational expense make them particularly suitable for heavy wall thickness welding. In addition, much higher travel speed for successful root pass welding and very high productivity can be achieved by optimizing the P-GMAW + laser process. The combined P-GMAW and laser process is one of the current development directions of the HLAW. The P-GTAW is a very effective variant of GTAW which offers lower heat input, narrower heat affected zone, finer grain size, less residual stresses and distortion, improved mechanical properties, enhanced arc stability to avoid weld cracks and reduce porosity when compared to conventional GTAW.

Laser welding is a crucial joining technology to obtain welds with high quality, high precision, high depth-width aspect ratio welds at productive travel speeds with minimal distortion. LBW is a promising technology for automotive industries due to its high degree of thermal efficiency, very low thermal distortion of the weld assemblies, high speed welding and enhanced productivity in comparison with other fusion process. RLW has been shown to be a viable method for sheet metal joining in automotive applications, from both engineering and cost perspectives. RLW pose as a tough competitor for RSW in producing weld stitches in the automotive industries. The RLW can perform remote weld stitches with different size and orientation based on the design requirements of the parts, whereas RSW can produce a round spot weld nugget of a size determined by the gun tip size. Significant reduction in cycle time can be achieved with RLW when compared to RSW, it is one of the primary motivations for factory owners to switch to RLW.

Newly developed complex engineering alloys can deliver greater performance, improved cost-effectiveness, superior reliability and better safety while also reducing ecological impact. There is an ever-increasing demand for these complex engineering alloys which can be utilized in highly aggressive environments. Structural alloys having sufficient CTOD

properties, high yield strengths and good impact toughness down to -60°C are developed for offshore structures. Newer alloys with high resistance to corruptions or high resistance to sulphuric and hydrochloric acids are developed for chemical processing industries. Very good thermal shock resistance and good wear resistance alloys that take advantage of the excellent properties of rare earth metals are developed for mining industries. Joining dissimilar multi-material assemblies have been of significant and growing interests. Multi-material structures are developed for manufacturing lightweight frames and chassis in the automotive industries. Nano-engineering is an effective tool to exploit the potential of materials for their use in automotive and shipbuilding industries. Advanced welding wires capable of providing high tensile strength, good impact toughness, low spatter levels, easy to remove slag and the smooth and stable arc have been developed for Offshore and shipbuilding applications. Metal matrix composites and ceramic matrix composites finds potential successful engineering application aerospace structures as they use high elastic modulus of ceramics and high metal ductility to achieve better combination of properties. With the rising complex material systems, these materials are more vulnerable to complicated changes in microstructure during the weld thermal cycle. As advanced materials continue to evolve, sophisticated manufacturing processes need to be continuously developed. Hence it is important that welding research go in parallel with discovery of new alloys.

Industries especially the automotive and aerospace industries can significantly benefit from introduction of robotic manufacturing units. Robotic welding systems can improve upon the productivity of the process by not only offering high speed and greater productivity but also by improving the weld cosmetics, reducing the reworks and repairs, reducing over-welding and by reducing labor costs. Computer simulated welding process can significantly improve the productivity of the process and helps in identifying potential obstacles in the process in the early stage. Simulation techniques offer an alternative, not only for efficiency estimation but also for determining the characteristics of the weld. Computational modelling has helped engineers understand the microstructure and behaviour changes during welding. Adaptive welding systems can adapt to frequently changing welding conditions, for instance, the pre-machining errors, variation in gap size and position arising from the inappropriate work-piece fitting, distortion in positioning due to heat transfer in workpiece. Co-existence of welding machines and computers on the same network supports many within the organization to

access and share the information at any time and in a simplified manner. Weld data monitoring systems can effectively track the productivity of the welding system. Precise and accurate weld monitoring systems used before, during and after welding process are developed to significantly improve the automated process control through effective feedback systems. Intelligent welding system with advanced sensors and feedback system have been developed to adapt to a dynamic welding environment thereby improving the effectiveness of the current teaching and playback type robotic systems. Next generation intelligent welding systems are being developed by incorporating the human welder's experiences and skills into the robotic welding system

Safety regulatory bodies such as Occupational Safety and Health Administration (OSHA) have developed new standards to help protect employees against potential health hazards in the workplace. Finding efficient controls to decrease the toxicity of heavy metals evaporated from the welding process is the most direct way to protect workers. While some of these more advanced safety technologies may seem excessive in certain welding applications, each carries out an important task in protecting the welder's health, senses, and comfort — all of which start with the head. Various practical methods are available that effectively restrict the reach of welder to the fumes and other welding related hazards Source capture systems are used for applications involving small parts and fixture welding. Modular hoods are increasingly becoming popular in medium size workspace. Curtains or hard walls may be added to create a booth or enclosure when workplace conditions permit. An ambient system is more practical to control fumes in a facility with multiple operations. A complete solution to this problem can only be achieved with combined efforts of the industries, safety regulatory and workers. Prevention is always the best medicine. Proper training of graduate level engineers is also vital in ensuring safe and reliable operations of welded structure

The study concludes by stating that, gradually adopting the practical strategies mentioned in this thesis would help the manufacturing industries to achieve on the following:

- Reduced power consumption
- Enhanced power control and manipulation
- Increased deposition rate
- Reduced cycle time
- Reduced joint preparation time

- Reduced heat affected zones
- Reduced repair rates
- Improved joint properties
- Reduced post-weld operations
- Improved automation
- Improved sensing and control
- Avoiding hazardous situations from operator
- Reduced exposure of potential hazards to welder.

These improvement can help reduce the ecological footprint of the welding process. Hence the study lends strong support to the fact that the usage of eco-friendly welding equipment and quality weld joints obtained with the minimum possible consumption of energy and materials should be the main directions for the improvement of welding systems in-order to have reduced ecological footprint.

8 SUMMARY

Implementation of new environmental, health and safety laws have created demands in the industries for effective manufacturing methods with reduced ecological impacts. Welding is one of the most demanding process in both the manufacturing and fabrication industries. It consumes a significant amount energy and material in these industries. It is also one of the most significant sources of toxic fumes and gas emissions. Therefore industries face the need for reducing the weld related inefficiencies and hazards in the manufacturing process in order to gain competitiveness in the market. A qualitative approach is used to find practical solutions that can improve energy and material consumption during the welding process. A critical review of the factors including improved weld power source efficiency, efficient weld techniques, newly developed weld materials, intelligent welding systems, weld safety measures and personnel training.

The evolution of power supplies for the welding process have been explained. A basic introduction on conventional power sources and their evolution into the modern inverter based power supplies followed by their comparisons is provided. Benefits of the modern inverter based power supplies have been discussed e.g. Output power supply modes, arc manipulation. Examples of their working in welding processes have been explained. Industries can adopt smart inverter power supplies in-order to have better control over the process, reduced energy consumption, improved compactness, improved weld quality and reduced costs.

The developments in different welding methods have been discussed. The basic idea behind each welding process, their developments, comparisons and their specific benefits have been presented. Significant improvements in the ecological aspects and weld characteristic improvements of selected welding processes (Friction stir welding (FSW), Hybrid welding, Gas metal arc welding (GMAW), Gas Tungsten arc welding (GTAW), Submerged arc welding (SAW), Laser beam welding (LBW)) and their variants have been discussed. Challenges in the conventional welding processes can be avoided by adopting new process variants which solves those problems. Depending upon the specific requirements of the industries, they can choose welding processes that best suits their needs.

Based on the application sector, developments in new materials have been presented. In each application, their material property requirement, previous materials used, newly developed materials and their improvements in property have been discussed. The application sectors discussed include power plant, aerospace, oil and gas, shipbuilding, automotive, mining, chemical process industries and offshore applications. Newly developed materials can deliver greater performance, improved cost-effectiveness, superior reliability and better safety while also reducing ecological impact.

Developments in welding automation have been explained with focus to Robotic and Adaptive welding systems. The benefits of the articulating weld robots and industrial weld positioners have been detailed. The different sensing methods used in the adaptive welding and the uses of the weld data management systems have also been presented. Future welding systems that can learn the experience based behavior and skill of a human welder has been explained. The consistency in weld production using automated welding systems along with other advantages, makes the industries adopting robotic technology gain a competitive edge. Weld data monitoring systems can empower the industries by effectively tracking the productivity based on the information (total number of welds made and total parts welded, percentage of downtime compared to arc-on time, and deposition rates) collected and provide detailed performance reports on each of the user's weld cells.

Practical methods that effectively restrict the reach of welder to the fumes and other welding related hazards have been discussed. Information on weld related safety hazards and fume formation mechanism has been provided followed by effective fume emission control methods. Benefits of Integral fume extraction torches, exhaust ventilation systems, personal protective equipment have been provided. Industries adopting fume emission control methods not only satisfy regulatory compliance but build up trust with the customer and employee by maintaining an optimal welding operator safety.

Adopting these practical methods would help manufacturers to reduce their consumption, satisfy government regulations and remain competitive in the market.

REFERENCES

ABB, 2015. *IRB 7600*. [Online]
Available at: <http://new.abb.com/products/robotics/industrial-robots/irb-7600>
[Accessed 19 04 2015].

Alghamdi, T. & Liu, S., 2014. Low Transformation Temperature welding consumables for residual stress management : Consumables development and testing qualification. *The Welding Journal*, Volume 7, pp. 243 - 251.

Antonini, J. et al., 2007. Effect of short-term stainless steel welding fume inhalation exposure on lung inflammation, injury, and defense responses in rats. *Toxicology and Applied Pharmacology*, Volume 223, pp. 234-245.

Avner, S. H., 1997. *Introduction to physical metallurgy*. New Delhi: McGraw-Hill Education (India) Pvt Limited.

Aydin, K., Kaya, Y. & Kahraman, N., 2012. Experimental study of diffusion welding/bonding of titanium to copper.. *Material Design*, Volume 37, pp. 356-368.

Balasubramanian, M., Jayabalan, V. & Balasubramanian, V., 2008. Developing mathematical models to predict grain size and hardness of argon tungsten pulse current arc welded titanium alloy. *Journal of Materials Processing Technology*, Volume 196, pp. 222-229.

Bill, W., 2014. The future of welding education. *The Welding Journal*, Volume 4, pp. 38-41.

Bird, T., 1993. Inverter power sources: An efficient alternative. *Welding Journal*, 72(1), pp. 37-40.

Blecher, J., Palmer, T., Kelly, S. & R.P., M., 2012. Identifying Performance Differences in Transmissive and Reflective Laser Optics Using Beam Diagnostic Tools. *The Welding Journal*, 91(7), pp. 204s-214s.

Boen, B., 2009. *A Bonding Experience: NASA Strengthens Welds*. [Online] Available at: http://www.nasa.gov/topics/nasalife/friction_stir.html [Accessed 02 02 2015].

Campbell, F., 2006. *Manufacturing technology for aerospace structural*. Great Britain: Elsevier.

Campbell, S. W., Galloway, A. M. & Mcpherson, N. A., 2012. Artificial Neural Network Prediction of Weld Geometry Performed Using GMAW with Alternating Shielding Gases. *The Welding Journal*, 91(5), pp. 174s-181s.

Cao, R., Yu, G., Chen, J. & Wang, P., 2013. Cold metal transfer joining aluminum alloys-to-galvanized mild steel. *Journal of Materials Processing Technology*, Volume 213, pp. 1753-1763.

Cao, X. et al., 2011. Hybrid fiber laser – Arc welding of thick section high strength low alloy steel. *Materials and Designs*, 32(16), pp. 3399-3413.

Caron, J. L., Britton, M. A., Meck, N. S. & White, H. J., 2011. Ni-Mo-Cr Alloy Shows Versatility in Corrosion Resistance. *The Welding Journal*, 90(3), pp. 40-43.

Cary, H. & Helzer, S., 2005. *Modern Welding Technology*. Upper Saddle River, New Jersey: Pearson Education.

Celik, S. & Gunes, D., 2012. Continuous Drive Friction Welding of Al/SiC Composite and AISI 1030. *The Welding Journal*, 91(8), pp. 222s-228s.

Celina, L. M. d. S. & Américo, S., 2006. The influence of double pulse on porosity formation in aluminum GMAW. *Journal of Materials Processing Technology*, 171(3), pp. 366-372.

Chandravathi, K. S. et al., 2010. *Assessment of the integrity of ferritic-austenitic dissimilar weld joints of different grades of Cr-Mo ferritic steels..* Liege, Belgium, s.n.

Chen, J. S., Lu, Y., Li, X. R. & Y.M., Z., 2012. Gas Tungsten Arc Welding Using an Arcing Wire. *The Welding Journal*, 2012(10), pp. 261s-269s.

Chen, S., 2007. On the key intelligentized technologies of welding robot.. *Lecture Notes in Control and Information Sciences*, Volume 362, pp. 105-116.

Chen, S., Wang, W. & Ma, H., 2010. Intelligent control of arc welding dynamics during robotic welding process. *Journal of Materials Science Forum*, Volume 638 - 642, pp. 3751-3756.

Czyryca, E. J., 1993. Advances in high strength steel technology for naval hull construction.. *Key Engineering Materials*, Volume 84-85, pp. 491-520.

Dan, W., 2013. Fume Extraction Guns: Understanding the Basics. *The Welding Journal*, 92(4), pp. 51-53.

David, H., 2014. What can a welding positioner do for you. *The Welding Journal*, Volume 2, pp. 42-45.

Deacon, R., DuPont, J. & Marder, A., 2007. High temperature corrosion resistance of candidate nickel-based weld overlay alloys in a low NO_x environment.. *Material Science And Engineering A*, Volume 460-461, pp. 392-402.

Deanna, P., 2015. *Fume Extraction: Not a One-Size-Fits-All Decision*. [Online] Available at: http://www.lincolnelectric.com/en-us/support/welding-solutions/Pages/fume-extraction-solutions.aspx?WT.mc_id=social_fb_fume [Accessed 20 04 2015].

Dennis, J. H., Hewitt, P. J., Redding, C. A. J. & Workman, A. D., 2001. A Model for Prediction of Fume Formation Rate in Gas Metal Arc Welding (GMAW), Globular and Spray Modes, DC Electrode Positive. *The Annals of Occupational Hygiene*, 45(2), pp. 105-113.

Dennis, J. & Mortazavi, S., 1996. *The mechanism of fume and spatter formation in MIG welding.*, Bradford: Metal Fume Research Unit Occasional Technical Report 9608, University of Bradford.

Dunbar, B., 2014. *Proven Friction Stir Welding Technology Brings Together Reliability and Affordability for NASA's Space Launch System*. [Online]

Available at: <http://www.nasa.gov/exploration/systems/sls/12-056.html#.VNHL29KUfp8>
[Accessed 02 02 2015].

DuPont, J. et al., 2004. Physical and Welding Metallurgy of Gd-enriched ions - Part II Nickel based alloy.. *Welding Journal*, 83(11), pp. 289s-300s.

DuPont, J., Stockdale, A., Caizza, A. , & Esposito, A., 2013. High Temperature Corrosion behaviour of alloy 600 and 622 weld cladding and coextruded coatings. *Welding Journal* , 92(7), p. 218s.

DuPont, N. J., 2014. Welding of Nickel-based alloys for energy applications. *The Welding Journal*, 93(2), pp. 31-45.

ESAB and AGA, 1999. *Facts about MIG/MAG welding.*, s.l.: ESAB Welding Equipment AB.

Fan, Y. Y. et al., 2012. Ultrasonic Wave Assisted GMAW. *The Welding Journal*, 91(3), pp. 91s-99s.

Fenglin, L., Huabin, C., Chongjian, F. & Shanben, C., 2010. A novel control algorithm for weld pool control.. *Industrial Robot: An International Journal*, Volume 89-96, p. 37.

Fine, M. E., Ramanathan, R., Vaynman, S. & Bhat, S., 1993. *Mechanical properties and microstructure of a weldable high performance low carbon steel containing copper.* s.l., s.n., pp. 18-21.

Furukawa, K., 2006. New CMT arc welding process – welding of steel to aluminium dissimilar metals and welding of super-thin aluminium sheets. *Welding International* , 20(6), pp. 440-445.

García-Cordovilla, C. et al., 1994. Microstructure and susceptibility to stress corrosion cracking of Al-Zn-Mg weldments (AA-7017). *Materials Science and Engineering: A*, 174(2), pp. 173-186.

Gardner, B. & Sommers, E., 2011. Protecting the Head. *The Welding Journal*, 90(8), pp. 38-41.

Ghainia, F. M., Sheikha, M., Torkamanyb, M. & Sabbaghzadeh, J., 2009. The relation between liquation and solidification cracks in pulsed laser welding of 2024 aluminium alloy. *Materials Science and Engineering A*, 519(1-2), pp. 167-171.

Golden, P., Grandt, A. & Bray, G., 1999. A comparison of fatigue crack formation at holes in 2024-T3 and 2524-T3 aluminum alloy specimens. *International Journal of Fatigue*, Volume 21, pp. s211-s219.

Gray, C., 1980. *Fume formation in electric arc welding*, Bradford: University of Bradford.

Greg, S., 2012. Selecting Fume Collectors for Welding Applications. *The Welding Journal*, 91(12), pp. 73-76.

Grujicic, M. et al., 2010. Modeling of AA5083 material-microstructure evolution during butt friction stir welding. *Journal of Materials Engineering and Performance*, 19(5), pp. 672-684.

Hang, Z.-X., Yu, Y.-Y., Xu, G.-J. & Zhang, J.-Q., 2014. The control system for a DC pulse welding machine. *Welding Journal*, Issue July, pp. 36-38.

Harada, H. et al., 1999. *The State-of-the-Art of AC GMAW Process in Japan*, s.l.: IIW Doc. XII.

Heinimann, M. et al., 2007. *Validation of advanced Metallic hybrid concept with improved damage tolerance capabilities for next generation lower wing and fuselage applications*. Naples, Italy, s.n.

Hewitt, P., 1994. Reducing fume emissions through process parameter selections. *Occupational Hygiene*, Volume 1, pp. 35-45.

Himmelbauer, K., 2003. *Digital Welding*, s.l.: Fronius International, Property reports and presentations.

Huang, Y., Y., S. & Zhang, Y., 2012. Nonlinear Modeling of Dynamic Metal Transfer in Laser-Enhanced GMAW. *The Welding Journal*, 91(5), pp. 140s-148s.

Huang, Y. & Zhang, Y. M., 2010. Laser enhanced GMAW. *The Welding Journal*, 89(9), pp. 181s-188s.

Huang, Y. & Zhang, Y. M., 2011(a). Laser enhanced metal transfer — Part I: System and observations. *The Welding Journal*, 90(10), pp. 183s-190s.

Huang, Y. & Zhang, Y. M., 2011(b). Laser enhanced metal transfer — Part II: Analysis and influence factors. *The Welding Journal*, 90(11), pp. 205s-210s.

Hull, L. et al., 2000. *Advanced Neutron absorbers for DOE SNF Standardised Canisters - Feasibility Study*, Idaho, USA: Idaho National engineering and Environmental Laboratory Report .

Ian, D. H., 2011. Welding Advances in Tube and Pipe Applications. *The Welding Journal*, 90(6), pp. 58-63.

Jaskulski, K., 2010. *Robotyzacje OTC z wykorzystaniem niskoenergetycznych metod spawania*. [Online]

Available at: <http://www.sap.poznan.pl/fotki/File/DW300%281%29.pdf>
[Accessed 16 10 2014].

Kah, P., Suoranta, R. & Martikainen, J., 2012. Advanced gas metal arc welding processes. *International Journal of Advanced Manufacturing Technology*, 67(1-4), pp. 655-674.

Karsten, S., Nils, F. N. & Klaus-Dieter, L., 2014. Welding Equipment under the Energy-related Products Directive. *Journal of Industrial Ecology*, 18(4), pp. 517-528.

Katayama, S., 2005. New development in laser welding. In: *New developments in advanced welding*. Cambridge England: Woodhead Publishing Limited.

Kawano, S. et al., 1998. Weldability of helium-containing stainless steels using YAG laser. *Journal of Nuclear Materials*, Volume 258, pp. 2018-2022.

Keith, P., 2011. What's New in Flux Cored Filler Metals?. *The welding Journal*, 90(3), pp. 36-38.

Kimoto, I. & Motomatsu, R., 2007. *CO₂-gas-shielded One-side Welding Process Two-electrode "NS-Oneside MAG"*, s.l.: Nippon Steel Technical Report.

Kitagawa, Y. & Kawaski, H., 2013. Recent Development of High-strength and Tough Welding Consumables for Offshore Structures. *Kobelco Technological Review*, Volume 32, pp. 1-8.

Knoll, B. & Moons, A., 1999. *Feasibility of a reduced threshold limit value for welding smoke*, Delft: TNO Building and Construction Research, report 98-BBI-R1285.

Koen, F., 2015. *INNOJOIN: Development and evaluation of advanced welding technologies for multi-material design with dissimilar sheet metals*. [Online] Available at: <http://www.bil-ibs.be/en/onderzoeksproject/innojoin-development-and-evaluation-advanced-welding-technologies-multi-material-d> [Accessed 30 03 2015].

Kohn, G., 2001. *Improved process and apparatus for friction stir welding*. Israeli Patent Application, Patent No. 142101.

Kvaale, P. E. & Olsen, S., 1999. *Experience with supermartensitic stainless steels in flowline applications..* The Hague, The Netherlands, s.n.

Larry, B., 2012. How Today's Power Sources Aid Pulsed GMAW. *The Welding Journal*, 91(4), pp. 48-51.

Lebedev, V. & Maksimov, S., 2012. *Advanced mechanised equipment for welding and surfacing and its technical and technological possibilities*. Kiev: Osnova: s.n.

Lebedev, V., Sorokin, M. & Belov, A., 2014. Algorithms for controlling inverter sources of welding current to optimize the electrode metal transfer parameters. *Welding International*, 28(12), pp. 957-961.

Leister, B. & DuPont, J., 2012. Fracture Toughness of Simulated Heat- Affected Zones in NUCu-140 Steel. *The Welding Journal*, 91(2), pp. 52s-58s.

Li, K., Chen, J. & Zhang, Y., 2007. Double-electrode GMAW process and control. *The Welding Journal*, Volume 86, pp. 231s-237s.

- Lippold, J. C. & Kotecki, D. J., 2005. *Welding Metallurgy and Weldability of Stainless Steels*. s.l.:John Wiley & Sons, Inc.
- Liu, A., Tang, X. & Lu, F., 2013. Study on welding process and prosperities of AA5754 Al-alloy welded by double pulsed gas metal arc welding. *Materials and Designs*, Volume 50, pp. 149-155.
- Liu, Y., Zhang, W. & Zhang, Y., 2014. A tutorial on learning human welder's behavior: Sensing, modeling, and control. *Journal of Manufacturing processes* , Volume 16, pp. 123-136.
- Li, X. R., Zhang, Y. M. & Kvidhal, L., 2013. Penetration Depth Monitoring and Control in Submerged Arc Welding. *The Welding Journal*, 92(2), pp. 48s-56s.
- Li, Y., Wang, J. & Liu, P., 2003. *Weld of dissimilar metals and their applications in industries*, Beijing: Chemical Industry Press.
- Lorenzina, G. & Rutilib, G., 2009. The innovative use of low heat input in welding: experiences on 'cladding' and brazing using the CMT process. *Welding International*, 23(8), pp. 622-632.
- Lua, Y. et al., 2014. Double-electrode arc welding process: Principle, variants, control and developments. *Journal of Manufacturing Processes*, Volume 16, pp. 93-108.
- Luer, K., DuPont, J., Marder, A. & Skelonis, C., 2001. Corrosion fatigue of alloy 625 weld cladding exposed to combustion environments. *Materials at high temperature* , Volume 18, pp. 11-19.
- Luisa, Q., 2014. Welding Personnel Qualification the European way.. *The Welding Journal*, Volume 4, pp. 51-55.
- Lu, Y., Zhang, Y. M. & Kvidhal, L., 2013. Heat Input Reduction in Fillet Welding Using Bypass and Root Opening. *Welding Research*, Volume 92, pp. 390s-400s.

Madadi, F., Ashrafizadeh, F. & Shamanian, M., 2012. Optimization of pulsed TIG cladding process of stellite alloy on carbon steel using RSM. *Journal of Alloys and Compounds*, 510(1), pp. 71-77.

Marshall, A. W. & Farrar, J. C. M., 1998. *Welding of ferritic and martensitic 13%Cr steels*, s.l.: IIW Doc IX-H-422-98.

Ma, X. & Zhang, Y., 2011. Gas Metal Arc Weld Pool Surface Imaging: Modeling and Processing. *The Welding Journal*, 90(5), pp. 85s-94s.

Miller Welds, 2015. *FILTAIR® Capture 5 Fume Extraction System*. [Online] Available at: <http://www.millerwelds.com/products/fumeextraction/product.php?model=M00494> [Accessed 20 04 2015].

Miller, 2015. *PAPR (Powered Air Purifying Respirator)*. [Online] Available at: http://www.millerwelds.com/products/welding_protection/filtration/papr/#load-panel-titanium-9400i [Accessed 20 04 2015].

Millerwelds, 2015. *FILTAIR Low Profile Hood Cutaway*. [Online] Available at: http://images.millerwelds.com/main.php/v/product_photos/Fume+Extraction/FILTAIR+Low+Profile+Hood+Cutaway.jpg.html [Accessed 20 04 2015].

Mishra, R. & Ma, Z., 2005. Friction stir welding and processing. *Materials Science and Engineering R*, Volume 50, pp. 1-78.

Moreira, P. & Silva Lucas, F. d. C., 2012. Structural Connections for lightweight metallic structures. *Advanced Structured Materials*, Volume 8, p. 264.

Morishima, Y. et al., 2004. Re-weldability of neutron irradiated Type 304 and 316L stainless steels.. *Journal of Nuclear Materials*, Volume 329, pp. 663-667.

Movahedi, M., Kokabi, A., Reihani, S. & Najafi, H., 2012. Effect of tool travel and rotation speeds on weld zone defects and joint strength of aluminium steel lap joints made by

friction stir welding.. *Science and Technology of welding and joining*, Volume 17, pp. 162-167.

Nabeel, A. & Hyun, C., 2014. Alternating current-gas metal arc welding for application to thin sheets. *Journal of Materials Processing Technology*, 214(9), pp. 1828-1837.

Nadzam, J., 2003. *Gas Metal Arc Welding: Process Overview*, s.l.: Lincoln Electric Company, Technology Center.

Nandan, R., DebRoy, T. & Bhadeshia, H., 2008. Recent advances in friction-stir welding – process, weldment structure and properties.. *Progress in Material Science*, 53(6), pp. 980-1023.

Na, S., 2008. Weld seam monitoring. In: *Real-time Weld Process Monitoring*. Cambridge, England: Woodhead Publishing and Maney Publishing, pp. 131-163.

National Aeronautics and Space Administration, 2013. *Marshall Space Flight Center Core Products*, Huntsville, AL 35812: George C. Marshall Space Flight Center.

National Aeronautics and Space Administration, 2001. *Friction Stir Welding*. [Online] Available at: http://www.nasa.gov/sites/default/files/104835main_friction.pdf [Accessed 02 02 2015].

Necsulescu, D., 2011. The effects of corrosion on the mechanical properties of aluminum alloy 7075-T6. *UPB Science Bulletin*, 73(1), pp. 223-229.

Needham, J., 1962. Control of transfer in aluminium consumable electrode welding. In: *Physics of welding arc*. London: The institute of welding, pp. 114-124.

Nigel, S. & Kevin, C., 2012. What's New for Welding Aluminum in the Auto Industry. *The Welding Journal*, 91(1), pp. 34-37.

Ogura, T. et al., 2012. Partitioning evaluation of mechanical properties and the interfacial microstructure in a friction stir welded aluminum alloy/stainless steel lap joint.. *Scripta Materialia*, 66(8), pp. 531-534.

- Oikawa, H., Ohmiya, S., Yoshimura, T. & Saitoh, T., 1999. Resistance spot welding of steel and aluminum sheet using insert metal sheet. *Science and Technology of Welding and Joining*, Volume 4, pp. 80-88.
- Ola, O. & Doern, F., 2014. A study of cold metal transfer clads in nickel-base INCONEL 718 superalloy. *Materials and Design*, Volume 57, pp. 51-59.
- Olivera, P. et al., 2014. Fume and gas emission during arc welding: Hazards and recommendation. *Renewable and Sustainable Energy Reviews*, Volume 37, pp. 509-516.
- Palani, P. & Murugan, N., 2006. Selection of parameters of pulsed current gas metal arc welding. *Journal of Materials Processing Technology*, Volume 172, pp. 1-10.
- Paul, D., 2013. What You Should Know about Hybrid Laser Arc Welding. *The Welding Journal*, 92(1), pp. 38-41.
- Peter, J. H. & Andrew, D. W., 1997. Health Consideration in Metal Arc Welding. *Australian Welding Journal*, 42(2), p. 23.
- Pires, I., 1996. *Analysis of the influence of shielding gas mixtures on features of MIG/MAG*, Lisbon: Lisbon Technical University.
- Pires, I., Quintino, L. & Miranda, R., 2007. Analysis of the influence of shielding gas mixtures on the gas metal arc welding metal transfer modes and fume formation rate. *Materials and Design*, Volume 28, p. 1623–1631.
- Prater, T., 2014. Friction Stir Welding of Metal Matrix Composites for use in aerospace structures. *Acta Astronautica*, Volume 93, pp. 366-373.
- Praveen, P., Yarlagaadda, P. & Kang, M., 2005. Advancements in pulse gas metal arc welding. *Journal of Material processing technology*, Volume 164-165, pp. 1113-1119.
- Purslow, M. A., 2012. Reducing the Ecological Impact of Arc Welding. *Welding International*, Volume 1, pp. 24-27.

- Qin, G., Lei, Z. & Lin, S., 2007. Effects of Nd:YAG laser + pulsed MAG arc hybrid welding parameters on its weld shape. *Science and Technology of Welding and Joining*, 12(1), pp. 79-86.
- Qi, X. & Liu, L., 2011. Investigation on Welding Mechanism and Interlayer Selection of Magnesium/Steel Lap Joints. *The Welding Journal*, 90(1), pp. 1-7.
- Rathod, M. & Kutsuna, M., 2004. Joining of aluminum alloy 5052 and low-carbon steel by laser roll welding. *Welding Journal*, Volume 83, pp. 16s-26s.
- Reddy, G., Rao, A. & Mohanda, T., 2008. Role of electroplated interlayer in continuous drive friction welding of AA6061-AISI 304 dissimilar metals.. *Science and technology of welding and joining*, Volume 9, pp. 83-89.
- Ribic, B., Palmer, T. & DebRoy, T., 2009. Problems and issues in laser-arc hybrid welding. *International Materials Reviews*, 54(4), p. 223244.
- Robert, L. B. & Jeff, G., 2013. Inverters Improve Control for AC Gas Tungsten Arc Welding. *The Welding Journal* , 92(7), pp. 28-30.
- Robert, M. & Marianna, F., 2011. Remote Laser Beam Welding: A Cost-Effective, High-Productivity Tool for Manufacturing. *The Welding Journal*, 90(5), pp. 52-57.
- Roberts, D. I., Ryder, R. H., Thurgood, B. E. & Viswanathan, R., 1987. *Improved dissimilar welds for superheater and reheater tubes..* Chicago, s.n.
- Saha, A. & Olson, G. B., 2007. Computer aided design of transformation toughened blastresistant naval hull steels: Part 1. *Journal of Computer-Aided Materials Design*, Volume 14, pp. 177-200.
- Sakiyama, T. et al., 2013. Dissimilar metal joining technologies for steel sheet and aluminum alloy sheet in auto body. *Nippon steel technical report*,, Issue no. 103, pp. 91-99.

Schneider, J., Beshears, R. & Nunes, A., 2006. Interfacial sticking and slipping in the friction stir welding process. *Material Science Engineering A*, Volume 435-436, pp. 297-304.

Selco, 2015. *Selco Green Wave Weld*. [Online] Available at: <http://greenwave.selcoweld.com/en/> [Accessed 2015 01 02].

Seto, K. & Matsuda, H., 2013. Application of nanoengineering to research and development and production of high strength steel sheets. *Materials Science and Technology*, 29(10), pp. 1158-1165.

Shang, J. et al., 2012. Microstructure characteristics and mechanical properties of cold metal transfer welding of Mg/Al dissimilar metals. *Materials and Design*, Volume 34, pp. 559-565.

Shi, C., Zou, Y., Zou, Z. & Wu, D., 2014. Twin-wire indirect arc welding by modeling and experiment. *Journal of Materials Processing Technology*, Volume 214, pp. 2292-2299.

Shi, L., Wu, C. & Liu, H., 2015. The effect of the welding parameters and tool size on the thermal process and tool torque in reverse dual-rotation friction stir welding. *International Journal of Machine Tools and Manufacture*, Volume 91, pp. 1-11.

Shimada, W. & Ukai, J., 1981. *Effects of pulsed current control on welding quality improvement..* s.l., s.n.

Shiue, R., Wu, S. & Chan, C., 2004. The interfacial reactions of infrared brazing Cu and Ti with two silver-based braze alloys.. *Ti with two silver-based braze alloys.*, 9(1-2), pp. 148-157.

Siefert, A., Tanzosh, M., P.J., S. & Newell, W., 2011. EPRI P87: A Promising New Filler Metal for Dissimilar Metal Welding. *The Welding Journal*, 90(3), pp. 30-34.

Silva, C. & Scotti, A., 2006. The influence of double pulse on porosity formation in aluminum GMAW. *Journal of Materials Processing Technology*, Volume 171, pp. 366-372.

Smith, B., 2003. The Boeing 777. *Advanced Materials & Processes*, 161(9), p. 41.

Srinivasan, K. & Balasubramanian, V., 2011. Effect of Heat Input on Fume Generation and Joint Properties of Gas Metal Arc Welded Austenitic Stainless Steel. *Journal Of Iron And Steel Research, International*, 18(10), pp. 72-79.

Staley, J. & Lege, D., 1993. Advances in aluminium alloy products for structural applications in transportation.. *Journal de physique*, 3(C7), pp. C7-179-C7-190.

Stewart, M. & Lewis, O. T., 2013. 5 - Fabrication, Welding, and In-Shop Inspection. In: *Pressure Vessels Field Manual: Pressure Vessels Field Manual Common Operating Problems and Practical Solutions*. s.l.:Gulf Professional Publishing, pp. 217-345.

Susan, D., Robino, C. M. M. J. & and DuPont, J., 2006. A solidification diagram of Ni-Cr-Mo-Gd alloys estimated by quantitative microstructural characterization and thermal analysis. *Metallurgical and material transactions*, 37(A), pp. 2817-2825.

Taban, E., Dhooge, A., Kaluc, E. & Deleu, E., 2012. Effect of the Consumable on the Properties of Gas Metal Arc Welded EN 1.4003-Type Stainless Steel. *The Welding Journal*, 91(8), pp. 213s-221s.

The Lincoln Electric Company, 2014. www.lincolnelectric.com. [Online] Available at: <http://www.lincolnelectric.com/en-us/company/Pages/green-initiative-program.aspx> [Accessed 12 12 2014].

Thomas, P., 2013. Aluminum Welding Safety tips. *The Welding Journal*, 92(9), pp. 34-37.

Thomas, W. et al., 1991. *Friction stir welding*. England, Patent No. PCT/GB92102203.

Todd, M., 2012. Modern Power Source Technology Drives Process Improvement. *The Welding Journal*, 91(4), pp. 38-42.

Tolga Dursun & Costas Soutis, 2013. Recent developments in advanced aircraft aluminium alloys. *Materials and Design*, Volume 56, pp. 862-871.

Tong, H. & Tomoyuki, U., 2001. Features of low frequency modulated type pulsed MIG welding process. *Welding and Joining*, Volume 11, pp. 33-35,40.

- Tony, A., 2013. A new development in aluminium welding wire: Alloy 4943. *The Welding Journal*, 92(7), pp. 32-37.
- Tracey, R. & David, H., 2013. Benefits of Remote Laser Welding in the Automotive Industry. *The Welding Journal*, 92(1), pp. 48-53.
- Traidia, A., Roger, F. & Guyot, E., 2010. Optimal parameters for pulsed gas tungsten arc welding in partially and fully penetrated weld pools. *International Journal of Thermal Sciences*, Volume 49, pp. 1197-1208.
- Ueyama, T., Ohnawa, T., Tanaka, M. & Nakata, K., 2005(a). Occurrence of arc interaction in tandem pulsed gas metal arc welding. *Science and Technology of Welding and Joining*, 12(6), pp. 523-529.
- Ueyama, T. et al., 2005. AC pulsed GMAW improves sheet metal joining. *The Welding Journal*, 84(2), pp. 40-46.
- Warner, T., 2006. Recently-developed aluminium solutions for aerospace applications. *Material Science Forum*, Volume 519-521, pp. 1271-1278.
- Weman, K., 2003. *Welding Processes Handbook*. New York: CRC Press LLC.
- Verma, B., Atkinson, J. & Kumar, M., 2001. Study of fatigue behaviour of 7475 aluminium alloy. *Bulletin of Materials Science*, 231-236(2), p. 24.
- Vern, M., 2011. Certification program emphasizes safe use of Robots. *The Welding Journal*, 90(8), pp. 54-57.
- Victor, B., Farson, D. F., Ream, S. & Walters, C., 2011. Custom Beam Shaping for High-Power Fiber Laser Welding. *The Welding Journal*, 90(6), pp. 113s-120s.
- Voitkevich, V., 1995. *Welding fumes—formation, properties and biological effects*. Abington, Cambridge: Abington Publisher.
- Wu, C., Chen, M. & Lu, Y., 2005. Effect of current waveforms on metal transfer in pulsed gas metal arc welding. *Measurement Science and Technology*, 16(12), p. 2459–2465.

- Xu, N., Ueji, R. & Fujii, H., 2015. Enhanced mechanical properties of 70/30 brass joint by multi-pass friction stir welding with rapid cooling. *Science and Technology of Welding and Joining*, 20(2), pp. 91-99.
- Yang, S., Carlson, B. & Kovacevic, C., 2011. Laser Welding of High-Strength Galvanized Steels in a Gap-Free Lap Joint Configuration under Different Shielding Conditions. *The Welding Journal*, 90(January), pp. 8s-18s.
- Yang, S., Zhang, J., Lian, J. & Lei, Y., 2013. Welding of aluminum alloy to zinc coated steel by cold metal transfer. *Materials and Design*, Volume 49, pp. 602-612.
- Yue, X., Lippold, J., Alexandrov, B. & Babu, S., 2012. Continuous Cooling Transformation Behavior in the CGHAZ of Naval Steels. *The welding Journal*, 91(3), pp. 67s-75s.
- Yu, K.-M. et al., 2011. Decreasing biotoxicity of fume particles produced in welding process. *Journal of Hazardous Materials*, Volume 185, pp. 1587-1591.
- Zehnder, J., 1996. *Aluminium: Technology, application, and environment, a profile of a modern metal*. Pennsylvania: TMS Warrendale.
- Zhang, H. et al., 2009. The arc characteristics and metal transfer and its use in joining aluminum to zinc-coated steel. *Materials Science and Engineering A*, Volume 499, pp. 111-113.
- Zhang, W. et al., 2014. The effect of the welding direction on the plasma and metal transfer. *Optics and Lasers in Engineering*, Volume 58, pp. 102-108.
- Zhang, W., Liu, Y., Wang, X. & Zhang, Y., 2012. Characterization of Three-Dimensional Weld Pool Surface in GTAW. *The Welding Journal*, 91(7), pp. 195s-203s.
- Zhang, W. & Zhang, Y., 2012. Modeling of human welder response to 3D weld pool surface: Part I – principles. *Welding Journal*, Volume 91, pp. 310 - 318.
- Zhang, Y., 2008. *Real-time weld process monitoring*. Cambridge, England: Woodhead Publishing and Maney Publishing.

Zhang, Y., Jiang, M. & Lu, W., 2004. Double electrodes improve GMAW heat input control.. *Welding Journal*, 83(11), pp. 39-41.

Zheng, Z., Cai, B., Zhai, T. & Li, S., 2011. The behavior of fatigue crack initiation and propagation in AA2524-T34 alloy. *Materials Science and Engineering : A*, 528(4-5), pp. 2017-2022.

Zhou, Y. et al., 2012. Effect of Titanium Content on Microstructure and Wear Resistance of Fe-Cr-C Hardfacing Layers. *The Welding Journal*, 91(8), pp. 229s-235s.