



TOWARDS CARBON-NEGATIVE FUTURE OF THE PULP AND PAPER INDUSTRY

Possibilities of harnessing BECCUS in Finnish pulp mills

Lappeenranta–Lahti University of Technology LUT

Master's Programme in Energy Technology, Master's thesis

2023

Kasper Heikkilä

Examiners: Professor Esa Vakkilainen

Katja Kuparinen, D.Sc. (Tech.)

ABSTRACT

Lappeenranta–Lahti University of Technology LUT

LUT School of Energy Systems

Energy Technology

Kasper Heikkilä

Towards carbon-negative future of the pulp and paper industry – Possibilities of harnessing BECCUS in Finnish chemical pulp mills

Master's thesis

2023

67 pages, 27 figures, and 11 tables

Examiners: Professor Esa Vakkilainen and Katja Kuparinen, D.Sc. (Tech.)

Keywords: BECCUS, carbon capture, CCS, CO₂, sulphate pulp mill

This thesis covers different aspects of harnessing carbon capture at Finnish chemical pulp mills. The thesis was done for the Finnish Recovery Boiler Committee, and in the committee, there is total of 14 pulp mills, each having a kraft recovery boiler. Between 2018 and 2020 the total annual CO₂ emissions of these pulp mills was about 21 million tonnes. The main source of CO₂ at the mill is the recovery boiler, power boiler being the second largest source. Lime kiln is the third largest CO₂ source, with flue gas CO₂ concentration being higher.

The literature review goes through carbon capture technologies in general and examines aspects that make it special to have the carbon capturing at a chemical pulp mill. New technologies for carbon capture are researched, and even though for example using membranes in the capture is a promising technology, using an amine solution is still the only commercial-scale technology available. The captured CO₂ can be either stored underground or under the seabed to remove it from the atmosphere or it can be used together with hydrogen in synthetic fuel refining. The hydrogen generation needs large investments, it has a great electricity demand, and the fact that carbon dioxide capture from biogenic sources doesn't give any benefits through the European Union emission trading system makes it very likely unprofitable to capture the CO₂ of a pulp mill.

With IPSEpro modelling was done to see, whether there are suitable heat streams to power the carbon capturing system. It was found out that in an integrated pulp and paper mill a system capturing less than 6.8% of the recovery boilers carbon dioxide emissions is a possible solution, and the system also is in a reasonable scale. Also, a pulp-only mill was inspected, and there is enough heat to capture 66% of the CO₂, which is way beyond a reasonable scale, what comes to for example hydrogen generation.

TIIVISTELMÄ

Lappeenrannan–Lahden teknillinen yliopisto LUT

LUT Energiajärjestelmät

Energiatekniikka

Kasper Heikkilä

Kohti hiilinegatiivista sellu- ja paperiteollisuutta – mahdollisuudet hiilidioksidin talteenottoon suomalaisilla sellutehtailla

Energiatekniikan diplomityö

2023

67 sivua, 27 kuvaa ja 11 taulukkoa

Tarkastajat: Professori Esa Vakkilainen ja Katja Kuparinen, TkT

Avainsanat: BECCUS, CCS, CO₂, hiilidioksidin talteenotto, sellutehdas

Tässä diplomityössä käsitellään eri näkökulmia hiilidioksidin talteenoton mahdollisuuksista suomalaisissa sellutehtaissa. Työ tehtiin Suomen Soodakattilayhdistykselle, johon kuuluu 14 jäsentehdasta, joissa jokaisessa on soodakattila. Näiden tehtaiden vuosittaiset hiilidioksidipäästöt vuosien 2018 ja 2020 välillä olivat keskimäärin 21 miljoonaa tonnia. Sellutehtaan suurin yksittäinen päästölähde on soodakattila, voimakattilan ollessa toisena. Kolmanneksi suurin päästönlähde on meesauuni, jonka savukaasuissa on edellisiä suurempi hiilidioksidipitoisuus.

Kirjallisuuskatsauksessa paneuduttiin hiilidioksidin talteenottoteknologioihin yleisesti ja tarkasteltiin, mitkä ovat sellutehtaiden erityispiirteet talteenoton kannalta. Uusia talteenottoteknologioita kehitetään jatkuvasti, ja esimerkiksi membraanien käyttö kaasun erotuksessa nähdään lupaavana, mutta ainoa kaupallisen kokoluokan teknologia perustuu amiiniliuoksen käyttöön. Talteen otettu hiilidioksidi voidaan säilöä maan tai merenpohjan alle tai se voidaan jatkojalostaa yhdessä vedyn kanssa synteettiseksi polttoaineiksi. Vedyn tuotanto vaatii suuria investointeja sekä suuren määrän sähköä, ja biogeenisen hiilidioksidin talteenoton hyödyttömyys EU:n päästökaupan kannalta aiheuttavat sen, että hiilidioksidin talteenotto sellutehtaalta on todennäköisesti kannattamatonta.

IPSEpro-ohjelmistoa käytettiin mallintamaan talteenottolaitteiston käyttöön sopivia lämpövirtoja. Sellu- ja paperitehdasintegraatissa korkeimmillaan 6,8 % soodakattilan savukaasujen hiilidioksidista voitiin talteen ottaa, joka on kokoluokaltaan mahdollisessa mittakaavassa. Pelkkää sellua valmistavan tehtaan kohdalla vastaava luku oli 66 %, jolloin esimerkiksi vedyntuotannon mittakaava nousi saavuttamattomaksi nyky menetelmin.

ACKNOWLEDGEMENTS

First of all, I want to say that the whole journey through the studies in LUT University has been phenomenal. I am grateful to have had the privilege to study in an environment where I have been surrounded by wonderful individuals. It has been rewarding to study in a place where it feels like everybody is working for the common good and the atmosphere is supportive. The enthusiasm of the people at the university has reflected to my studying. Before starting my studies in Lappeenranta, I wouldn't have ever believed, how excited I could be about learning about computational mathematics or flow measuring devices at 8 am in the morning, and the big thanks goes to the lecturers.

I would like to express my gratitude to my thesis supervisors, Professor Esa Vakkilainen and Doctor Katja Kuparinen, for guiding me through my thesis and sharing their expertise to support my research. I am thankful for the members of the Finnish Recovery Boiler Committee for giving me this extremely interesting and current topic and sharing their knowledge and experiences in the meetings. Especially, I want to thank Doctor Jussi Saari, whose help and expertise with IPSEpro-modelling has been indispensable.

I am happy to have made several good friends during my studies. It has been a joy to be in their company, no matter whether it has been during an all-nighter in a computer lab, training in the gym or enjoying the delightful cuisine of Indiana Curry. The diligent spirit of the group aided me to complete my assignments in time and with decent grades, and it also taught me a resolute way of working. These people have made studying amusing day after day. Even though many of these people have already relocated from Lappeenranta, they still have a lot of importance in my life and every reunion feels like a celebration.

I want to thank my parents for guiding me in the early stages of my education path. The supportive but also demanding stance on education has been a good approach to teach a good level of seriousness that has led me gracefully through the whole education path. I have always had a feeling that I can make decisions in a way I think is the best and if I need support or wisdom, I have people whom to turn to. Also, I am extremely grateful for my parents for teaching by example, what is happiness, how to be a decent human being and how to treat people in a way they deserve to be treated. These are the important lessons that have formed me into who I am today.

Foremost, I would like to thank Merle for the wonderful times, before and during my thesis. It has been magnificent to share the daily routines with somebody and to have a common goal to talk about something else than work in the evenings. The weekends together in the Finnish nature or relaxing at home have given me a large amount of energy to continue working on Mondays. Most of all, even though the past two years have finally made Lappeenranta feel like home to me, I know that the future will be great, regardless of what will be the place of residence or work.

Lappeenranta 30.5.2023

Kasper Heikkilä

SYMBOLS AND ABBREVIATIONS

Roman characters

<i>I</i>	investment	[€]
LHV	lower heating value	[MWh/tonne]

Dimensionless quantities

F	Scaling factor
---	----------------

Superscripts

<i>0</i>	initial
<i>x</i>	new

Abbreviations

AWE	alkaline water electrolysis
BECCS	bioenergy with carbon capture and storage
BECCU	bioenergy with carbon capture and utilization
BECCUS	bioenergy with carbon capture, utilization and storage
BLG	black liquor gasification
Ca(OH) ₂	calcium hydroxide
CaCO ₃	calcium carbonate
CaO	calcium oxide
CCS	carbon capture and storage
CCU	carbon capture and utilization

CFB	circulation fluidized bed
CH ₃ OH	methanol
CH ₄	methane
CO ₂	carbon dioxide
DEA	diethanolamine
DME	dimethyl ether
DNCG	dilute non-condensable gases
EEA	European Economic Area
EEX	European Energy Exchange
ETS	emission trading system
EU	European Union
EUA	European Union allowance
EUAA	European Union aviation allowance
GDP	gross domestic product
H ₂	hydrogen
H ₂ O	water
HCOOH	formic acid
ISBL	inside battery limits
LUT	Lappeenranta-Lahti University of Technology LUT
MDEA	methyl diethanolamine
MEA	monoethanolamine
Na ₂ CO ₃	sodium carbonate
Na ₂ S	sodium sulphide
Na ₂ SO ₃	sodium sulphate

NaOH	sodium hydroxide
NH ₃	ammonia
NO _x	nitrogen oxides
O ₂	oxygen
P2C	power-to-chemical
P2G	power-to-gas
P2H ₂	power-to-hydrogen
P2L	power-to-liquid
P2M	power-to-methane
P2X	power-to-x
PEM	polymer electrolyte membrane
RWGS	reverse water-gas shift reaction
SO _x	sulphuric oxides
TRS	total reduced sulphur

Table of contents

Abstract

(Acknowledgements)

(Symbols and abbreviations)

1	Introduction	11
2	Terminology	12
3	Carbon dioxide emissions of pulp mills	14
3.1	Recovery boiler	14
3.2	Lime kiln	15
3.3	Biomass boiler.....	17
3.4	Disposal of odorous gases	18
3.5	Flue gas properties and carbon circulation.....	19
4	Finnish pulp industry in numbers	22
5	Driving forces of technology harnessing.....	26
5.1	Environmental aspects	26
5.2	Economical aspects	30
5.2.1	Emission trading	30
5.2.2	Investment costs of CCS systems	32
5.2.3	Electricity and energy consumption	33
5.2.4	Value of CO ₂ and CO ₂ -based products	33
5.2.5	Competition of carbon	34
5.3	Political aspects.....	34
6	Carbon capture technologies	36
6.1	Capturing from flue gas	38
6.1.1	Amine method.....	38
6.1.2	Membrane method	40
7	Possibilities of utilizing the captured CO ₂	42
7.1	Storage possibilities	42

7.2	Power to X.....	44
7.2.1	Outcomes	44
7.2.2	Processes and their efficiencies	46
7.3	Carbon dioxide usage at the site.....	48
8	Balance calculations of a retrofit carbon capture system	49
8.1	IPSEpro model	49
8.2	Integrated pulp mill	54
8.3	Pulp-only mill.....	56
8.4	Improving the performance.....	58
8.5	Improving the calculation system	59
9	Investment costs	60
9.1	Balance of refining for the investment calculations.....	60
9.2	Cost of the systems.....	63
10	Conclusions.....	66
	Bibliography	68

1 Introduction

This thesis was done in LUT laboratory of Sustainable Energy Systems for the Finnish Recovery Boiler Committee. Carbon dioxide capturing and synthetic fuels are seen as an important tool to fight against climate change, and it was examined if the Finnish pulp and paper industry has potential to jump on this bandwagon. The main targets of this thesis were to find out, whether it is possible to harness carbon dioxide capture at a pulp mill producing chemical pulp, what are the differentiating features of a pulp mill versus conventional power generation, what are the limiting factors of the capturing scale and how much would it cost to implement a carbon capture system.

Carbon capture is used mainly in the oil industry to increase the amount of oil extracted from an oil well. In general, in many instances, only fossil-based carbon dioxide emissions are seen as emissions, and in the past years also cases of capturing carbon from fossil emission sources, for example oil refineries and coal-fired power stations have been researched. Lately, in the European Union, projects including carbon capture from fossil emission sources combined with synthetic fuel production have started and have been funded through subsidies from the Union.

Since bio-based carbon dioxide is often not seen as pollution, not too much research has been done on carbon capture in emission sources containing bio-based carbon dioxide. Pulp and paper industry being business as any other business, it was examined what kinds of political decisions would either force or favour, or on the other hand, interfere, utilizing carbon capture in a chemical pulp mill and an examination was done to see, how would a carbon capture system fit a pulp mill.

2 Terminology

What is BECCUS? It is shortened from **bioenergy with carbon capture, utilization and storage**. The basic idea is explained by the carbon circulation schematics in Figure 1.

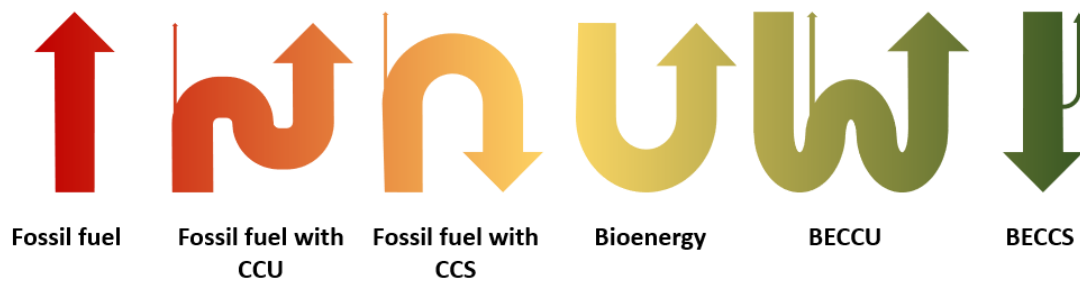

Figure 1 Carbon circulation schematics for different options

The thought behind bioenergy usage is that the biomass has absorbed the carbon it needs to assimilate and grow. The same carbon is then released back to the atmosphere when the biomass is combusted. This is quite similar situation to using fossil fuel with carbon capture and storage (CCS), carbon circulation-wise. The carbon is taken from underneath the ground as a fossil fuel, later it is captured and stored back underground. However, some extra carbon is added to the atmosphere, since 100% of the carbon dioxide cannot be captured. (Fajardy & Pour 2022; IEA 2022a)

In the applications where carbon capture and utilization (CCU) are adapted, almost always the carbon dioxide is released to the atmosphere. The thought behind the arrangement still is that it decreases the amount of released carbon dioxide: when fossil fuel is burned, the carbon dioxide is captured, and new fuel is produced based on the captured carbon dioxide, only little bit more than half of the carbon dioxide is released to the air compared to a situation in which all the fuel was fossil based. The same principle applies to carbon capture and utilization combined with bioenergy (BECCU): the synthetic fuel produced from the

carbon dioxide captured from biomass combustion can be used to replace fossil fuel usage. (Fajardy & Pour 2022; IEA 2022a)

Regarding bioenergy with carbon capture and storage (BECCS), the idea is that carbon dioxide can be captured from the combustion gases and stored underground. This is a situation, in which the carbon dioxide is removed from the atmosphere. While the biomass is growing, it absorbs the carbon dioxide from the air and when it is combusted, the carbon is captured and then injected under the ground. (Fajardy & Pour 2022; IEA 2022a)

3 Carbon dioxide emissions of pulp mills

There are several sources of carbon dioxide in a typical pulp mill. These sources vary with several important factors to consider, what comes to potential of carbon capture. In this paragraph the characteristics of different CO₂ sources are presented and discussed.

3.1 Recovery boiler

The recovery boiler is the largest CO₂ source in a pulp mill, producing more than two thirds of the total carbon dioxide emissions (Kuparinen et al. 2019). It generates most of the energy generated in a pulp mill and enables the reusage of the pulping chemicals, hence the name.

In a kraft pulping process, wood chips are cooked in a hot mixture, called white liquor, containing sodium sulphide (Na₂S), sodium hydroxide (NaOH), sodium carbonate (Na₂CO₃) and sodium sulphate (Na₂SO₃) mixed with water (Biermann 1996). The wood chips react with sodium sulphide and sodium hydroxide. This causes lignin bonds to break apart from the rest of the solid, which consist of fibrous cellulose and hemicellulose. (Tikka 2008; Prowledge Oy 2022)

Next, the fiber mass, also called pulp, is separated from the solution and washed. The excess cooking liquid, black liquor, goes through an evaporation process increasing the dry solid content up to +80%. During the evaporation process also methanol, turpentine and soap is separated from the black liquor. This prevents fouling in the recovery boiler and tall soap can then be processed to tall oil, which can be used for example as a raw material for bio-based transport fuels. (Tikka 2008; Prowledge Oy 2022)

After evaporation, the black liquor is fed to the recovery boiler, where the organic compounds, consisting mostly of lignin, burn and generate heat. This heat is used for the two main tasks of a recovery boiler: generating steam and making the chemical recovery reactions possible. In the recovery boiler, most of the cooking chemical, roughly two thirds, turn into sodium carbonate (Na₂CO₃). The rest of the cooking chemical turn into a smaller amount, roughly 20-30%, of sodium sulfide (Na₂S) and also some non-reacted sodium sulfate (Na₂SO₄) is left, depending on the wood used. This mixture of chemicals is removed

as smelt in the bottom of the recovery boiler. (Vakkilainen 2005; Alakangas et al. 2016; Prowledge Oy 2022)

Black liquor has relatively low calorific value, as well as a very different elemental composition compared to other wood-based fuels. The lower calorific value of black liquor is only between 12 and 15 MJ/kg, where other wood-based fuels are often close to 20 MJ/kg. This is because of the low amount of combustibles and the energy required by the chemical reactions in the recovery boiler: about one third of the dry solids is carbon and half of the dry solids is ash. (Vakkilainen 2005; Alakangas et al. 2016; Prowledge Oy 2022)

3.2 Lime kiln

The smelt removed from the recovery boiler is called green liquor. After being removed from the recovery boiler, the green liquor is treated by mixing it with water or weak white liquor, removing dregs and other impurities and cooling. Next, the green liquor is mixed with calcium oxide (CaO), which then turns into calcium hydroxide (Ca(OH)_2), also known as slaked lime, when reacting with water (H_2O) in the solution. Calcium hydroxide and sodium carbonate react, resulting in sodium hydroxide (NaOH) and calcium carbonate (CaCO_3). The calcium carbonate, now called lime mud, is separated from the sodium hydroxide and other chemicals that didn't react in re-causticizing and is prepared to be put back to the lime kiln. The rest of the solution goes back to cooking. (Vakkilainen 2017; Prowledge Oy 2022)

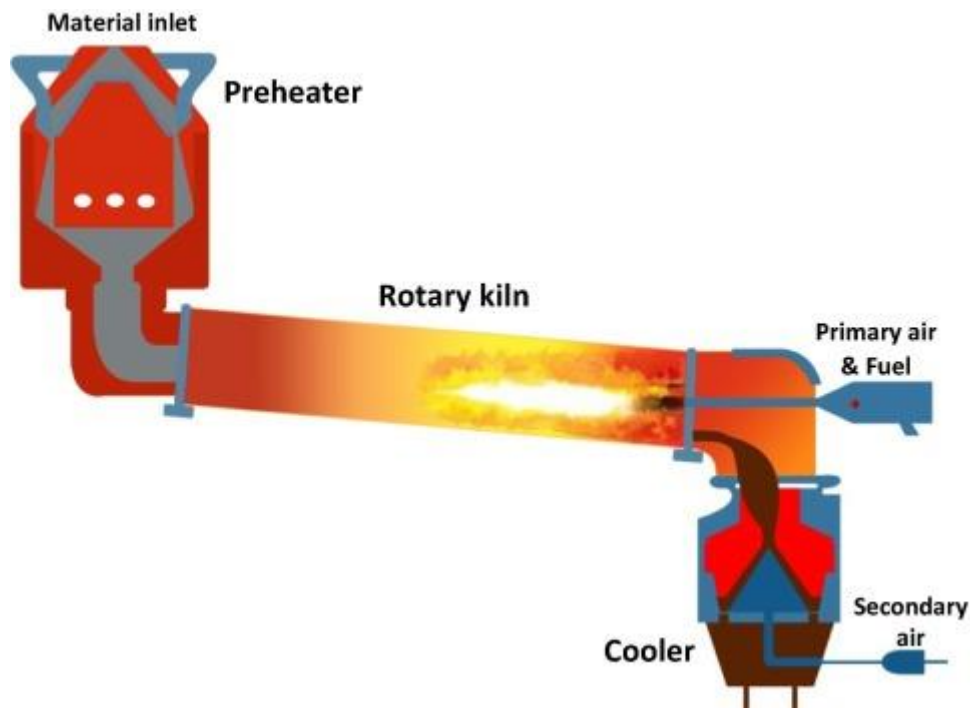

Figure 2 Lime kiln (Shahin et al. 2016)

Before being inserted to the lime kiln, presented in Figure 2, the lime mud is filtered and dried. After being dried to almost 100% dry solids, the lime mud is heated in the lime kiln for about one and a half to four hours at about 1100 °C. The reaction of calcium carbonate breaking into calcium oxide (CaO) and carbon dioxide (CO₂) starts at about 800-850 °C (Smook 2016; Prowledge Oy 2022). Higher temperatures fasten the reaction, and the hotter end of the lime kiln can be at 1250 °C (Smook 2016). The carbon dioxide from the process is currently released to the air, but it can also be captured. The amount of biogenic carbon dioxide is slightly under 200 kg per tonne of pulp. (Miner & Upton 2002; Prowledge Oy 2022)

This process is very energy intensive. The energy required is about 3000 kJ per a kilogram of CaO (Theliander 2009). This energy is often produced by natural gas or oil, but nowadays there are also several renewable options: syngas from bark gasifier, tall oil pitch or pulverized biofuels. Renewable fuels in Finnish lime kilns are presented in Table 1, and it seems that renewable fuels are the future fuels for lime kiln usage. (Berglin & Von Schenck 2022)

Table 1 Renewable fuels used in Finnish lime kilns (Berglin & Von Schenck 2022)

Mill	Lime kiln fuel
Metsä Joutseno	syngas (bark)
Metsä Kemi (starting in 2023)	syngas (bark)
Metsä Äänekoski	syngas (bark), tall oil pitch as secondary
Stora Enso Oulu	tall oil pitch
Stora Enso Sunila	lignin powder
Stora Enso Varkaus	syngas (bark, sawdust)
UPM Pietarsaari	tall oil pitch

In the pulp mills that use fossil fuels in the lime kiln, lime kiln is the largest fossil carbon dioxide emission source of the pulp mill itself, since otherwise fossil fuels are only used as start-up fuel and auxiliary fuel. Some integrated pulp mills use also natural gas to generate extra steam to power for example paper and cardboard manufacturing and sawmill usage. Additionally, the mills that use renewable fuels as the primary lime kiln fuel, often use fossil fuels as secondary fuel. In the mills that fire natural gas as the primary fuel in the lime kiln, the median fossil carbon emissions are about 100 kg per tonne of unbleached pulp. (Miner & Upton 2002; Kuparinen et al. 2019; Kotkamills 2020; Berglin & Von Schenck 2022)

3.3 Biomass boiler

A biomass boiler, a multi-fuel boiler or sometimes referring to the most combusted fuel, bark, a bark boiler is a boiler that burns the residue that is built up outside the pulping process and generates extra steam for the processes. Often it is a bubbling fluidised bed boiler, because the used fuel is moist and heterogeneous. As said, the main fuel of a biomass boiler is bark, but it also burns wood chips and many types of organic residues, for example residues from the water treatment plant. A biomass boiler also combusts the start-up fuel, meaning that in some cases it also uses fossil fuel. (Kuparinen et al. 2019; Prowledge Oy 2022)

3.4 Disposal of odorous gases

In a pulp mill, every process that deals with any type of liquor, releases odorous gases, e.g., methane. These gases can be divided into two categories: dilute non-condensable gases (DNCG) are unpleasant smelling and also explosive in high-enough concentration, while concentrated non-condensable gases (CNCG) are not only bad smelling, but also poisonous and highly explosive. In the pulping process larger amount of DNCG is formed and a smaller amount of CNCG. Sulphur-based odorous gases are known also as TRS (total reduced sulphur), and they are the ones causing the characteristic smell of pulp-producing cities. (Prowledge Oy 2022)

Since the 1990's, the amount of sulphur emissions, and also TRS emissions, have been decreased, as presented in Figure 3, due to tightened emission regulations. Mostly, and especially in modern technologies, the burning of odorous gases is done in the recovery boiler. However, an older technology to get rid of odorous gases is to burn them in a separate incinerator. The incinerator uses for example collected methanol and natural gas or oil to fuel the burning. Also, in the pulp mills that burn the odorous gases in the recovery boiler, there is also a separate burner in case of an interruption of the normal process. (Prowledge Oy 2022).

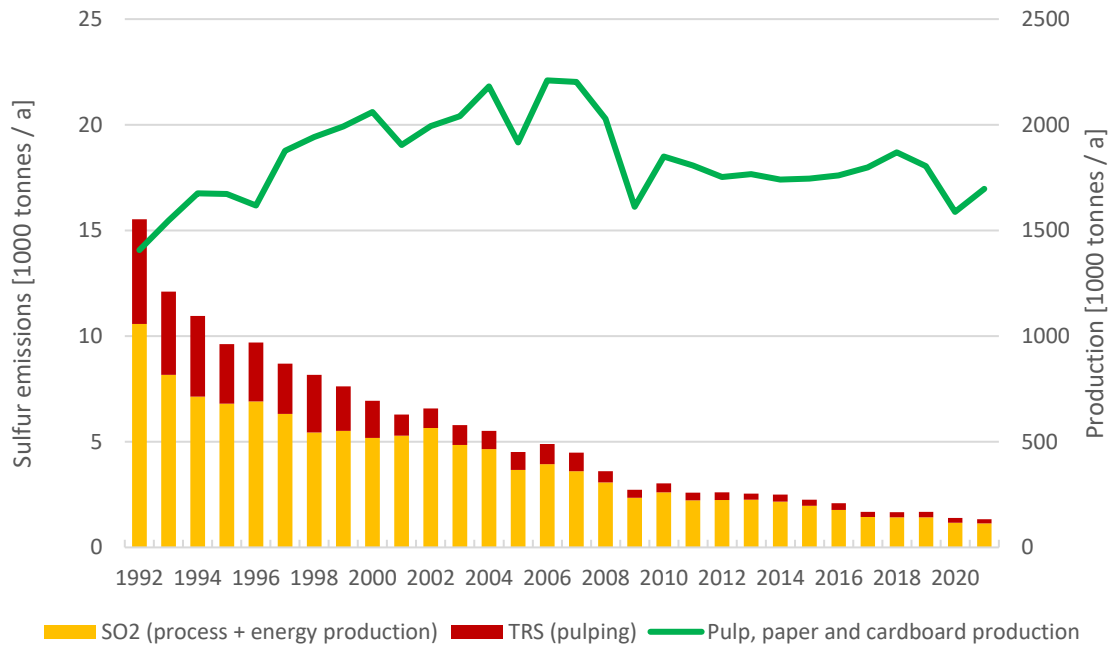

Figure 3 Sulphur emissions of Finnish industry (Metsäteollisuus)

3.5 Flue gas properties and carbon circulation

What comes to carbon capture, the most interesting characteristics of flue gases are its amount and its carbon dioxide and its carbon content. When it comes to developing the technology, moisture and sulphur content need to be considered as well to be aware of the possibilities of low temperature corrosion. (Teir et al. 2011)

Table 2 Estimations of flue gas properties in a pulp mill

	Share of total CO ₂ emissions	Flue gas CO ₂ content (wet)	Flue gas water content
Recovery boiler	68.0%	15.7%	22.9%
Bark boiler			
natural moisture bark	23.4%	19.7%	15.1%
press-dried bark	23.4%	22.1%	9.1%
Lime Kiln	8.6%	33.2%	9.6%

In Table 2 an example of flue gas distribution and properties is presented. The share of total CO₂-emissions is based on the Mill A (presented in Figure 4), an imaginary modern softwood kraft pulp mill located in Northern Europe, presented in publication Biomass-based carbon capture and utilization in kraft pulp mills by Kuparinen et al. 2019. In the publication “Kraft recovery boilers – Principles and practise” from 2005 by Esa K. Vakkilainen, measured values for recovery boiler flue gases are presented.

Values for bark boiler and lime kiln are calculated with typical values, lime kiln values including both combustion and chemical reaction emissions. Combusted bark is presented in two moisture contents: natural 47.5% and press-dried estimation 20% (Routa et al. 2021). The bark is combusted in 20% of excess air (Vakkilainen 2017). The amount of soot blowing steam is 5 w-% of dry fuel (Vakkilainen 2017). Since the natural gas available in Finland is almost completely methane, the calculations have been done for pure methane and with 2% leftover oxygen (Maakaasun käsikirja p. 6).

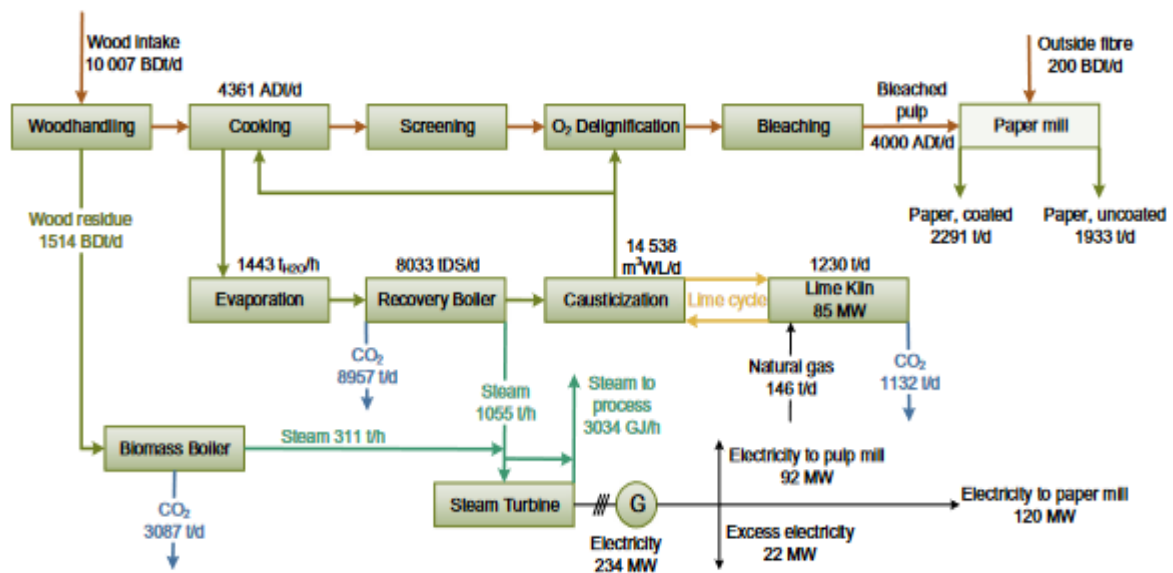

Figure 4 Mill A (Kuparinen et al. 2019)

The numbers presented in Table 2 raise questions about how the carbon capture technologies match with the desired amount of capturing. In case the desire is that all the carbon is captured, is it better or even possible to do the capturing from all of the flue gas flows with

one capturing system or is there a need to have individual systems for each type of flue gas flow. On the other hand, if only a part of the carbon is captured, is it better to capture the big amount of carbon from the recovery boiler flue gases or is the high-carbon lime kiln flue gas a more desirable source of capturing.

4 Finnish pulp industry in numbers

There are four companies in Finnish Recovery Boiler Association having total of 14 mills. As presented in Figure 5, the mills are widely spread all over Finland, excluding very northern Finland.

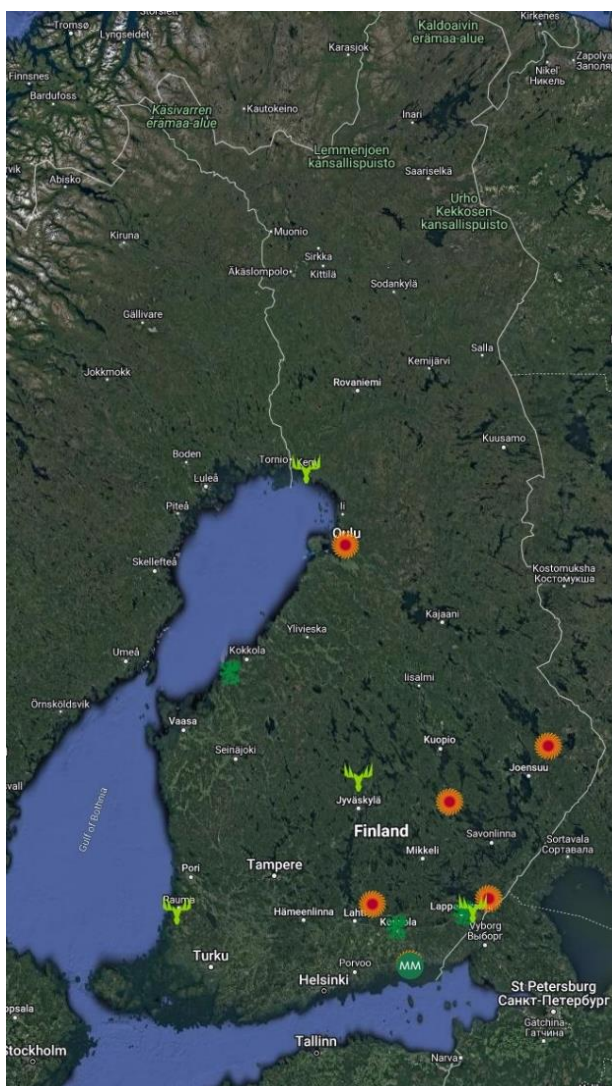

Figure 5 Finnish chemical pulp mills

On average, the total annual carbon dioxide emissions of these plants between years 2018 and 2020 have been approximately 21 000 000 tonnes. The fossil-based carbon emissions

are about one-twelfth of the total carbon emissions, being approximately 1 760 tonnes (EEA 2022). Figure 6 presents the carbon emission values of seven Finnish pulp mills.

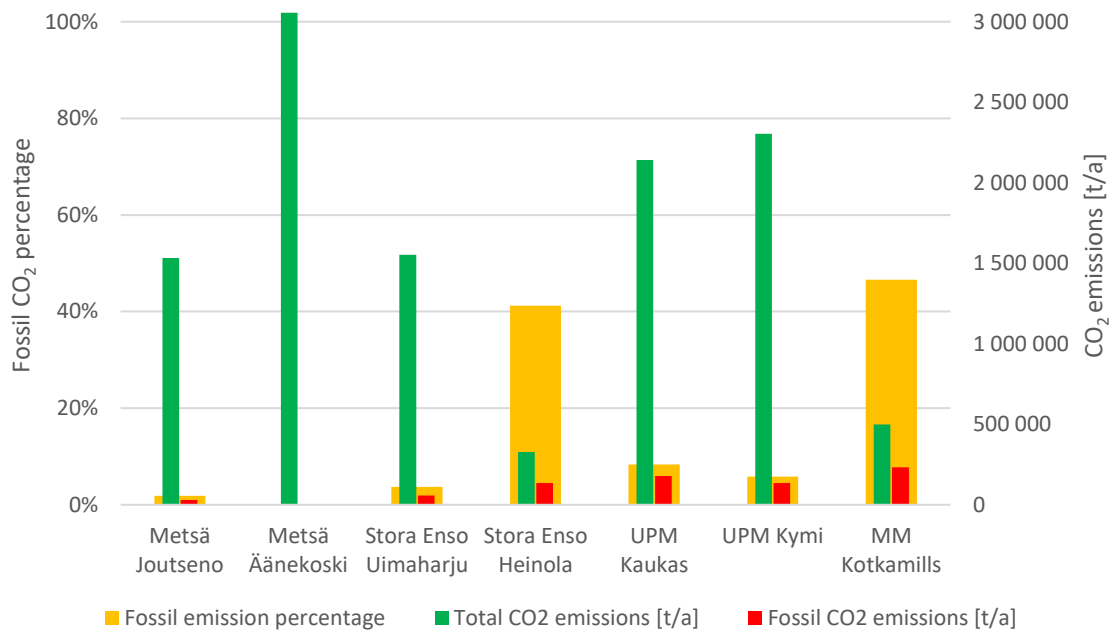

Figure 6 Key figures of seven Finnish pulp mills (EEA 2022)

The total carbon dioxide emissions are roughly twice the amount of local fossil carbon dioxide emissions from Finnish traffic and transportation sector (LVM 2020). This being said, it is unquestionable that quantitatively there is a great potential for forest industry to be the vanguard of large-scale carbon negativity.

The yearly wood consumption of Finnish forest industry is roughly 70 000 000 cubic meters per year, of which roughly 60 000 000 cubic meters are harvested from Finland. Roughly 40 000 000 cubic meters are used for mass production: 30 000 000 cubic meters of this is used for pulp making, and the rest, 10 000 000 cubic meters, for mechanical mass production, which is not considered further in this thesis. The yearly wood usage numbers are presented in Figure 7 and Figure 8. (Luke 2022)

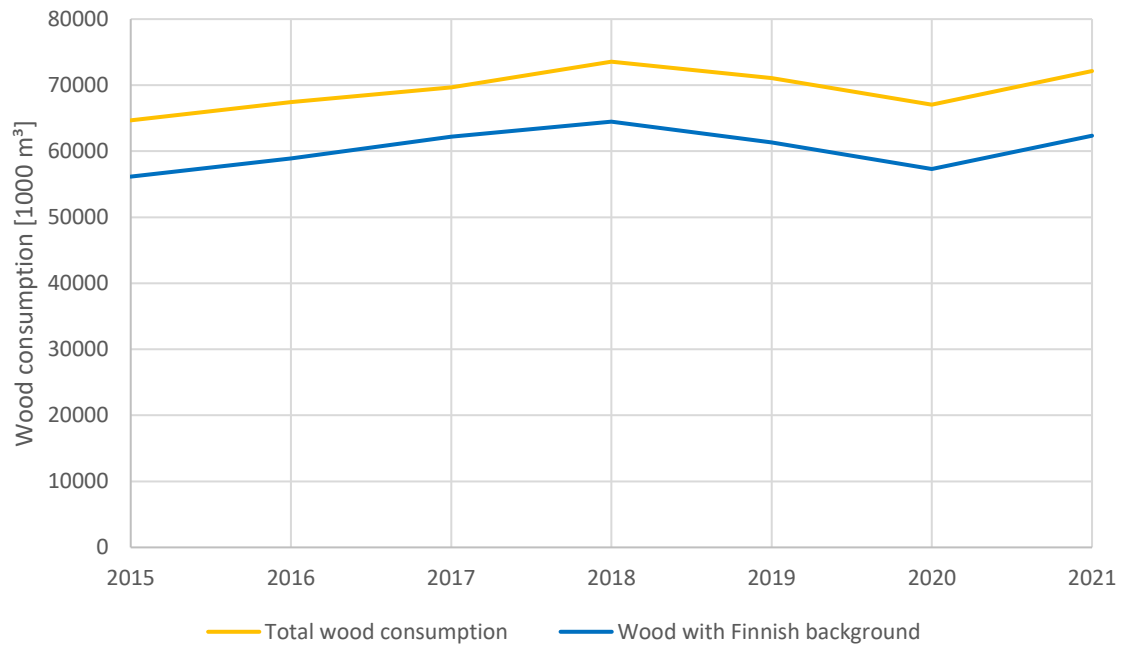

Figure 7 Wood usage of the Finnish forest industry (Luke 2022)

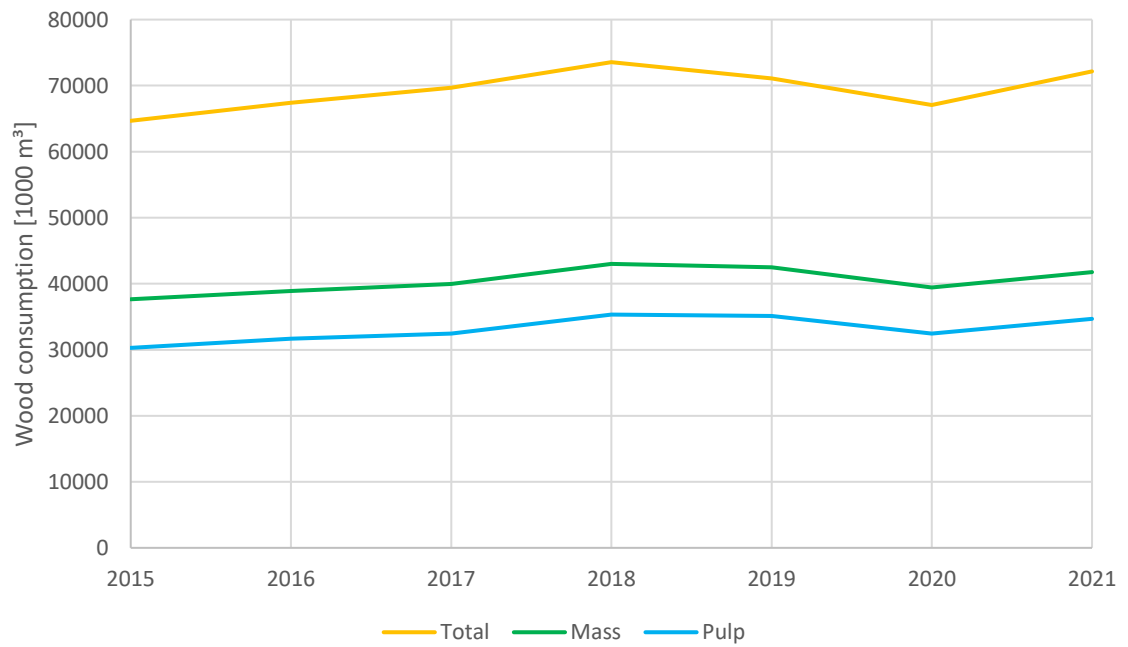

Figure 8 Segmentation of wood usage (Luke 2022)

The figures of wood usage are important, when the total CO₂ numbers of a country are calculated, since growing forest is seen as a carbon sink. Now, the questions are, does CCS increase the need of used wood or, on the other hand, would forest industry get an absolution of extra wood usage, if the carbon is captured.

In Figure 9 the annual production numbers of Finnish pulp, paper and cardboard are presented. These numbers show clearly the development of digitalization and internet shopping (Vaara 2021; Tiseo 2022).

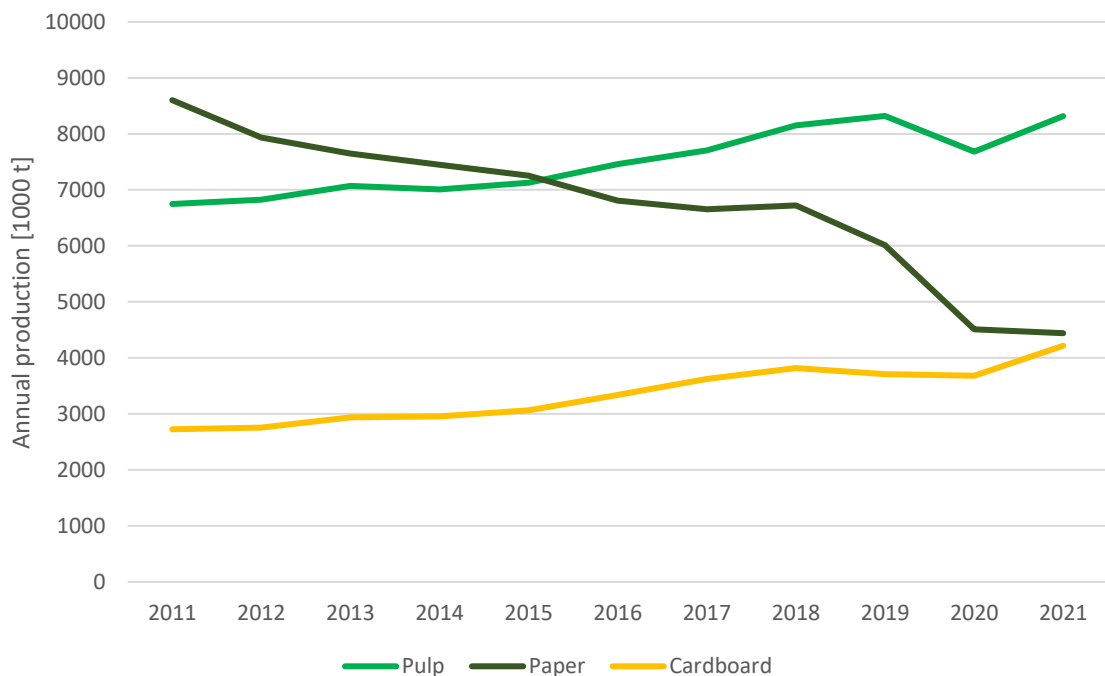

Figure 9 Annual Finnish production of pulp, paper and cardboard (Luke 2023)

5 Driving forces of technology harnessing

There is motivation of many aspects for reducing the carbon dioxide emissions, but also several retardants of technology introduction.

5.1 Environmental aspects

The clearest environmental thought behind CCS is to prevent carbon dioxide of being released to the atmosphere. When CCS is connected to a power plant that uses bio-based fuels, the idea is that carbon dioxide is removed from the atmosphere. The trees capture the carbon dioxide from the atmosphere when growing and when the wood is burned and the carbon dioxide is captured, the carbon dioxide is removed from the atmosphere. The idea of CCU is that in places where capturing carbon dioxide is more difficult and less cost-effective, carbon released already somewhere else can be reused and harnessed as a fuel. (Onarheim & Arasto 2018)

There are also questions about BECCUS with negative tone to them. Does it require more wood to be chopped? How is the extra energy for the capture systems generated? What are the environmental effects of the carbon storage?

In general, it can be said that usage of BECCUS doesn't necessary mean that more forest needs to be harvested, since the energy in the pulp mills is generated from the residue of the production. However, the system does need energy and introducing carbon capture may mean that the production of some other product needs to be lowered down, which can mean that it then needs to be replaced with something else. In case the energy, especially electricity, is bought from outside, the question is time-sensitive and depends on the general electricity production of Finland.

Carbon storage is often done by injecting carbon dioxide back to old natural gas sources. This also enables more natural gas to be able to be collected from the natural gas well. This can be considered to be both negative and positive thing: on the other hand, fossil fuel is burned, but on the other hand, if otherwise the same energy would be produced with coal or oil, it is the less bad option. (Teir et al. 2011)

Big question related to carbon capture and especially using the carbon dioxide to produce synthetic fuels is the large amount of electricity needed, mostly to generate the needed hydrogen. A large green electricity production is often seen as a solution for the question. In case a big amount of extra electricity is decided to be used for manufacturing products, it is necessary to realize that there is also a limit for harnessing solar and wind power. Most of the best places to harness wind power in Finland have already been put to use, as presented in Figure 10 and Figure 11. There can also be other types of obstacles, for example, related to national defence. (Ilmatieteen laitos 2009; Pohtila 2022; Finnish Wind Power Association 2022) .

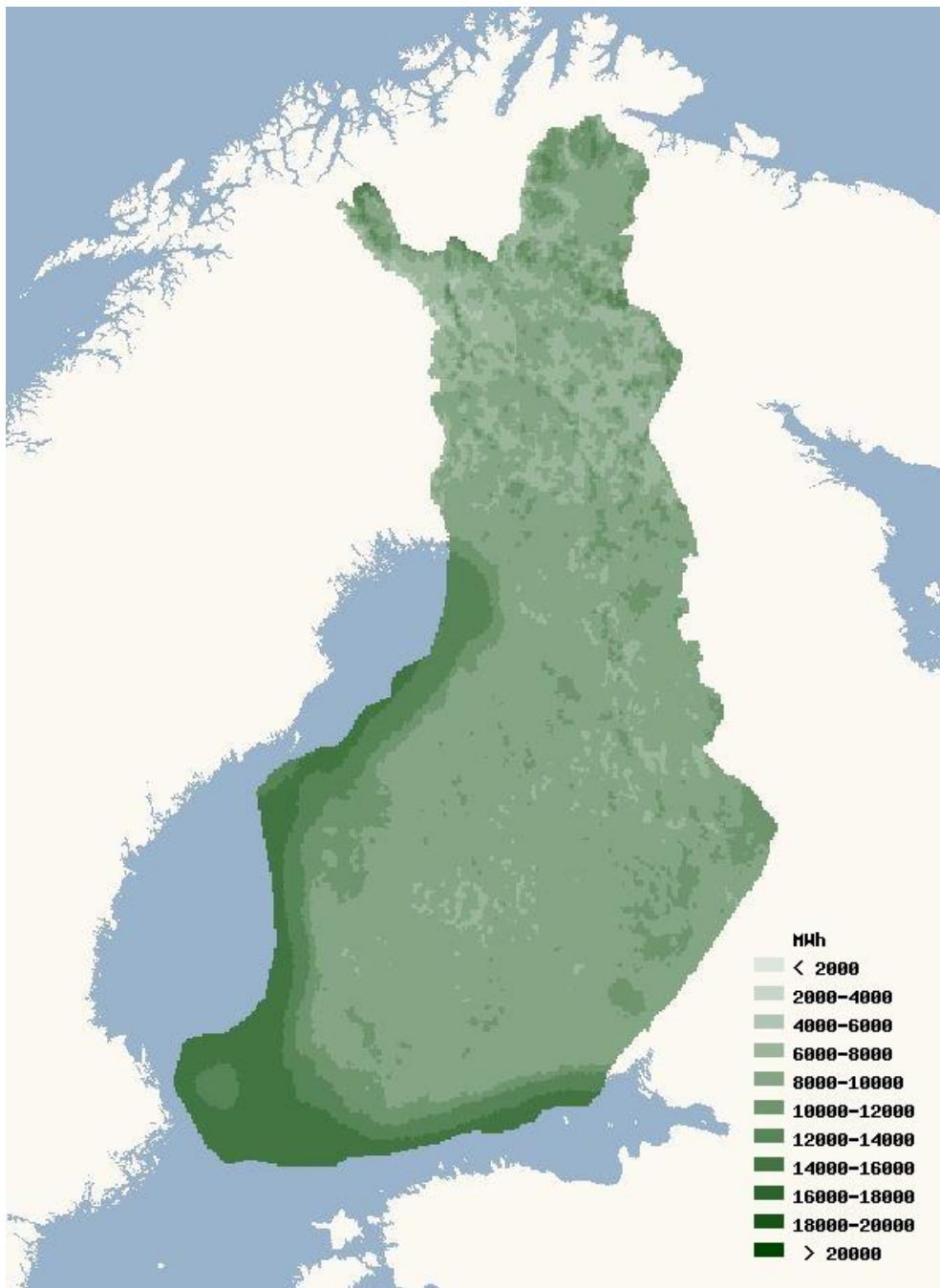

Figure 10 Potential annual energy production of a 3 MW wind turbine at 200 metres (Ilmatieteen laitos 2009)

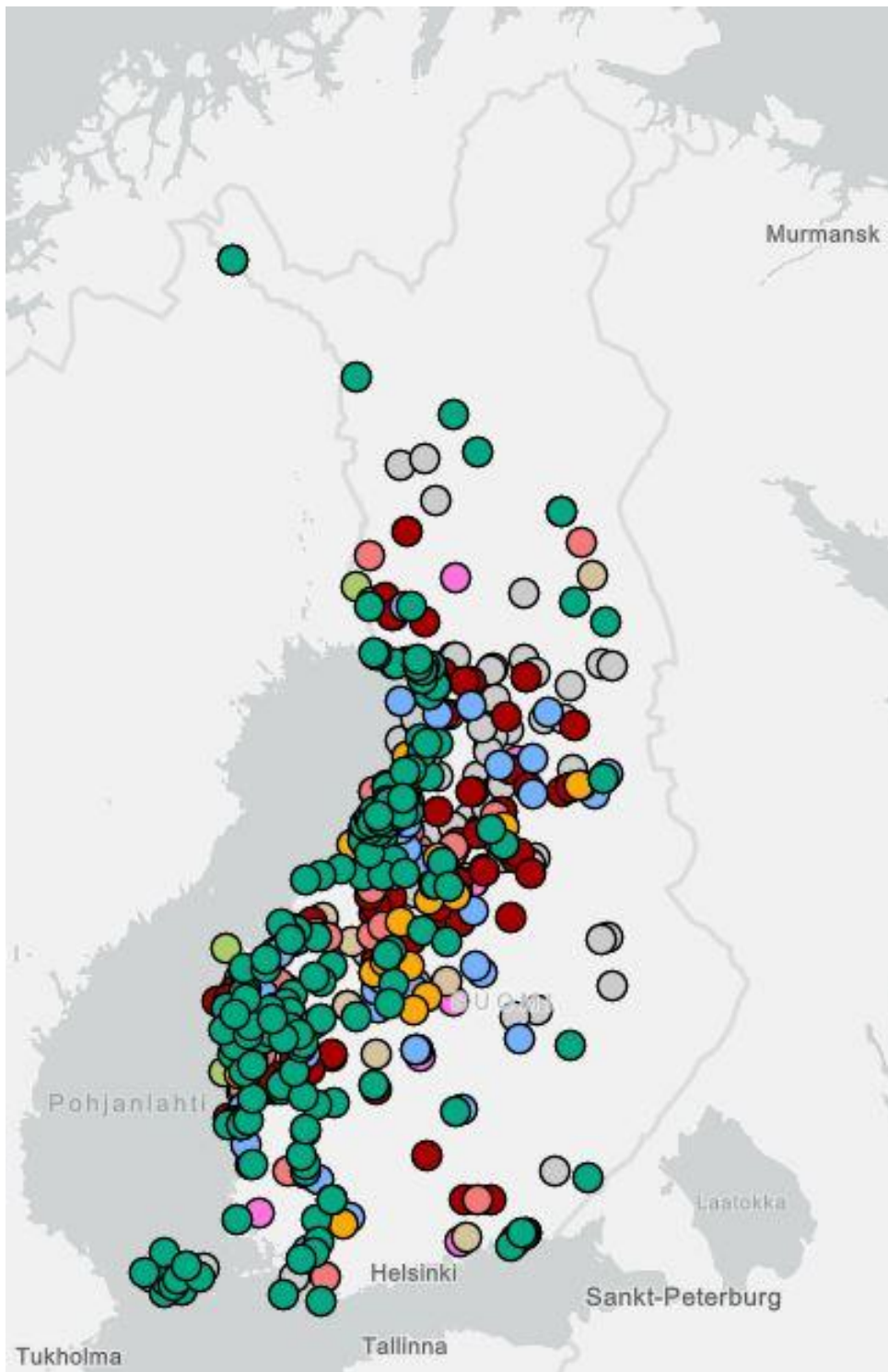

Figure 11 Wind power projects in Finland (Finnish Wind Power Association 2022)

5.2 Economical aspects

Since business is what industry is all about, the costs of changes always need to be deliberated. These costs often vary depending on several things. There are bigger, more obvious, often politically driven factors that will be calculated when the price of a CCS-system is evaluated, as speculated later. However, there can also be other, at least in the beginning smaller, aspects that cannot be valued clearly. For example, there might be a possibility that in the future there is a new market for CO₂-negative end products, like there is, for example, for chlorine-free pulp.

5.2.1 Emission trading

According to the European Union, “The EU ETS (European Union Emission Trading System) is a cornerstone of the EU's policy to combat climate change and its key tool for reducing greenhouse gas emissions cost-effectively. It is the world's first major carbon market and remains the biggest one.” The principle behind the EU ETS is simple: the polluter pays. (EC 2022a)

Basically, the way the EU ETS works is that the EU releases a limit for greenhouse gas emissions for heavy industry, energy production and aviation inside the European Economic Area (EEA) each year. The European Union divides 90% of this amount between the participant countries according to the emissions of the country of the year 2005 or the average of emissions of the years 2005-2007, whichever is greater. The rest (10%) is divided among the countries with a GDP of 90% or less of the EU's average to promote solidarity, growth and interconnections within the EU. (EU Directive 2018/410)

Inside the EU countries, the main way of distributing the emission allowances is auctioning, and in 2021, 57% of the general allowances were auctioned. The rest were given free as explained later. One emission allowance means a permit to emit one tonne of carbon dioxide. The countries need to use at least half of the money from auctioning to decrease greenhouse gas emissions. The general platform for the auction, located in Leipzig, Germany, is called EEX (European Energy Exchange), where most of the auctioning is done. EEX auctions two types of emission allowances: the general allowances, called EUA (EU Allowance), and

allowances for aviation, called EUAA (EU Aviation Allowance). Companies can buy emission allowances from either market as well as from other companies. Roughly half of the needed allowances of the aviation sector were bought from the EUA-market in 2019. (EU Directive 2018/410; EC 2022b)

100% of the emission allowances for sectors that are counted to belong to the carbon leakage risk sectors are given free (EC 2022c). This means basically that to prevent companies from moving to countries with less carbon emission regulations, emission allowances are given free for companies working in international markets. Also, for example, the production of district heating gets most of its emission allowances for free until 2026, when the amount drops significantly. On the other hand, electricity production must buy all its emission allowances in countries with GDP higher than 60% of the EU's average. (EU Directive 2018/410)

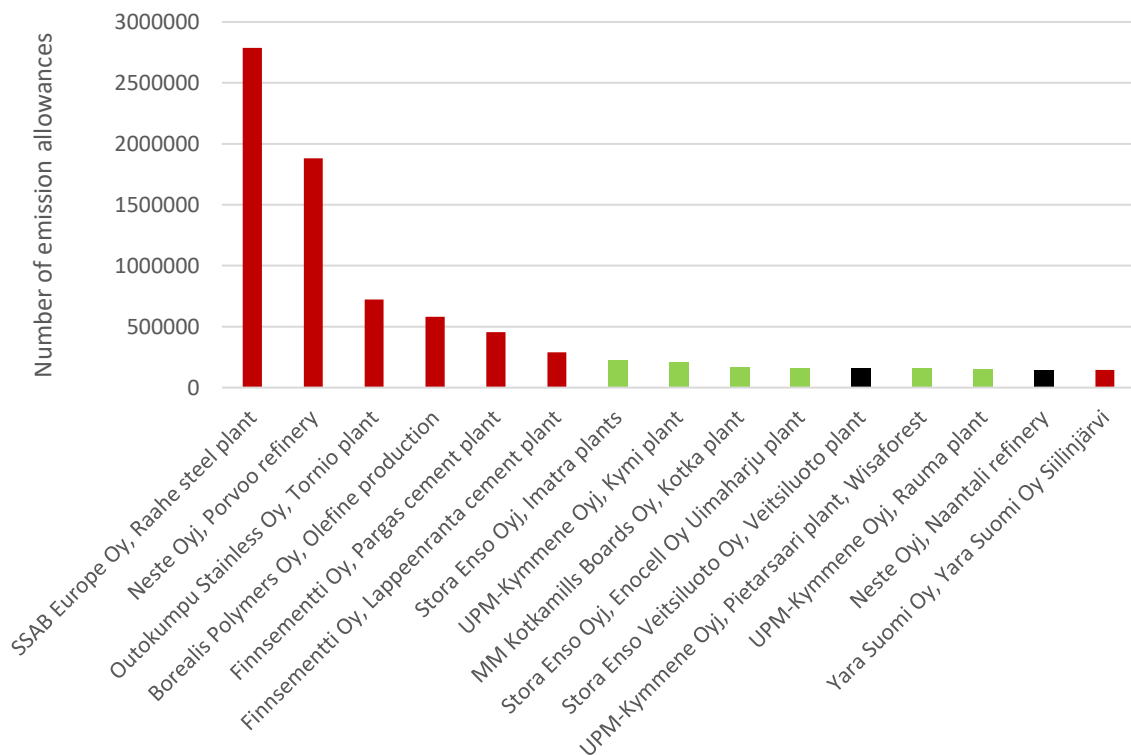

Figure 12 Emission allowances given for Finnish factories in 2021 (Energiavirasto 2023)

The top 15 receivers of free emission allowances in Finland are presented in Figure 12; in green working plants of forest industry are presented and other types of industry in red. The colour black presents closed factories. As it can be seen, pulp mills that use also fossil fuels get their emission allowances for free, until 2030 (EU Directive 2018/410).

The most interesting and game changing question would be taking negative carbon emissions into account in emission trading. This would increase the profitability of BECCUS significantly: in 2022 the average price of carbon emission allowance was a little bit over 80 € (Ember 2023). However, introducing a large amount of carbon removal technologies could also decrease the price of emission allowances, if the market stability reserve can't control the market as supposed (EC 2022d). Also, since half of the money from auctioning needs to be used for lowering the greenhouse gas emissions, BECCUS could be a good target for that.

5.2.2 Investment costs of CCS systems

Investment costs are a big question when it comes to carbon capture and storage systems. Until this day CCS has been typically utilized in oil and gas production. The carbon dioxide has been pumped back to the source to get more product out of the source, while CCS applications combined with firing biomass are under development (Rassool 2019; Department of Energy 2022). In September 2022, there were 30 facilities with CCS operational, 11 in construction and 153 under development. (Steyn et al. 2022)

The baseline of different pulp mills size-wise is quite different, as presented earlier in Figure 6. The choice between utility or storage as well as the location of the site have a significant effect on the size of the investment (Kjärstad et al. 2016). These factors combined with the fact that there isn't any well-applicable data from the previous projects, the investment cost of implementing CCUS into a pulp mill can be difficult, and that's why it probably is also very risky for the investors to take part into the project. As an example, Drax Group has planned to invest £40 million for the first phase of a BECCS project to capture annually 8 million tons of CO₂ (Drax 2021).

5.2.3 Electricity and energy consumption

In general, the fact that pulp mills have excess heat available, makes them an interesting target to integrate CCUS. Depending mostly on the integration degree of the pulp mill, there is a different amount of excess heat and electricity available. Amount of excess energy also reflects on the price of carbon capture and utilizing, and also, the other way around, the price of the end products of the pulp mill might change due to changes in carbon capturing rates (Kuparinen 2023, pp 657). What comes to electricity, the idea often is that the generated electricity can be used for capturing systems. In case of utilizing the carbon, there will be and needs to be a great amount of wind or solar energy to be used for the systems, since especially electrolysis is a large electricity consumer. (Onarheim et al. 2017)

It seems that the electricity need of pulp and paper industry has continuously gone down with a moderate trend, due to changes in production and increased efficiency (Koreneff et al. 2019; ET 2023). This change might release a small amount of energy to be used elsewhere. Another interesting question is, what is the future of, for example, paper production. The trend presented earlier in Figure 9 shows that the production of paper is going down, and since paper production is very energy intensive, this could mean that in the future there is excess energy being freed for different use. Meanwhile the amount of produced cardboard and also the demand of cardboard has gone up, some of the paper machines have been converted into cardboard machines and there are plans to do so for even more mills (Degerman 2021). In the case that after the conversion the energy usage is lower than before, there could be a good situation to consider carbon capture.

5.2.4 Value of CO₂ and CO₂-based products

An interesting economical aspect is the value of the end product. Even though carbon dioxide itself has a big market, the quantities used near the capturing location are most likely relatively low compared to the amount of CO₂ that can be captured from Finnish pulp mills. The worldwide CO₂ usage is more than ten times the CO₂ amount released from Finnish pulp mills, but the usage is far away from Finland (IEA 2019). However, using the captured carbon dioxide in another process nearby might be possible for some of the pulp mills, if there is big need nearby (Pirhonen 2022).

With excess electricity, refining the captured CO₂ to create a valuable is an option worth considering. A common thought is that with green electricity and captured carbon for example transportation can be relieved from the need of fossil fuels. The most basic compound that can be created by synthesizing carbon dioxide is methane, and recent studies have shown that methanol might be a profitable fuel to be made by a P2X-project (Blanco et al. 2018; Liquid Wind 2022). Also, many different types of fuel can be produced, as well as carbon-based precursors for chemical industry, but the complexity of the carbon chain also increases the amount of electricity needed for the synthesis. (Dahiru et al. 2022)

5.2.5 Competition of carbon

The basic idea of BECCUS is that carbon dioxide is released when burning lignin. However, there is also other types of projects going on to prevent CO₂ being released into the air. For example, since 2015 Stora Enso has recovered lignin in Sunila pulp mill (Pisto 2018). These projects can decrease the CO₂ emissions and excess energy of pulp mills; however, the chemical recovery still needs to be done. Even though there are other projects, it seems likely that the main characteristics of pulp mills will stay the same, since pulp itself has a bright future (Kalliokoski 2022).

5.3 Political aspects

The Paris Agreement, which the EU ratified on 5th of October in 2016, can be said to be the biggest political act towards the integration of BECCUS. According to the EU, “The Paris Agreement sets out a global framework to avoid dangerous climate change by limiting global warming to well below 2°C and pursuing efforts to limit it to 1.5°C. It also aims to strengthen countries’ ability to deal with the impacts of climate change and support them in their efforts.” Countries being part of the agreement are feverishly looking for ways to decrease the amount of carbon emissions, and carbon capturing is seen as one of the great possibilities. (EC 2022e)

In the EU, carbon capture is considered. Legislatively it is taken into account by approving a directive about geological storage of carbon dioxide (Directive 2009/31/EC). The potential of carbon capture and also BECCUS has also been acknowledged, but at the moment the usage of carbon capturing technologies would be paid by the user, as described in the paragraph 5.2.1, since negative emissions are not recognized in the ETS (Erbach & Victoria 2021). A thing that might be questionable during starting processes in forest industry is the EU's opinion on the sustainability of wood usage. In the EU, forest conservation has raised its head lately, meaning that there might be less from which to take, CO₂ or energy (Schönberg 2021). On the other hand, if the interpretation of the combustion of wood gets even tighter and the free emission allowances are no longer issued, BECCS might be a way to go (Toivonen 2022).

The European Union has generally been quite strict with the thought that in electrolysis-based green hydrogen production the electricity used for it must be additional, meaning that green electricity production must be built especially for it (Directive (EU) 2018/2001). However, these regulations have been loosened lately (Parkes 2022). The thought behind this is that in electricity network there always needs to be balance, and it wouldn't make sense to produce electricity with fossil fuels for other consumption because the renewable electricity is used for capturing carbon dioxide.

In Finland, the political institutions have acknowledged CCS as a possibility in the energy system development. At the moment in early 2023 the objectives are mostly elsewhere than in forest industry, projects about capturing the carbon dioxide from hydrogen production are taking wing and also more research is done on BECCUS. Neste Oyj has gotten funding from the EU for their project to capture CO₂ in hydrogen production and Tampereen Sähkölaitos Oy together with Nordic Ren-Gas Oy are having a project on capturing CO₂ from waste combustion flue gases (Sieppi 2021; Tampereen Sähkölaitos 2023).

There are also big growth plans for green hydrogen production in Finland and several hydrogen plant projects have started in Finland. To produce products with higher degree of processing carbon dioxide from pulp mills could be used. On the other hand, these projects often also have different plants for using the produced hydrogen. For example, carbon dioxide emissions of humankind could be decreased by producing synthetic protein and this way reducing the need for meat production. (Mäntylä 2023)

6 Carbon capture technologies

Carbon can be captured in different ways from combustion processes. Each of these techniques have their pros and cons. As presented in Figure 13, Figure 14 and Figure 15, there are three main ways of capturing carbon.

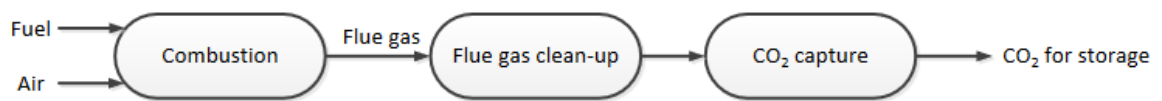

Figure 13 Post-combustion carbon capture (IEAGHG 2019)

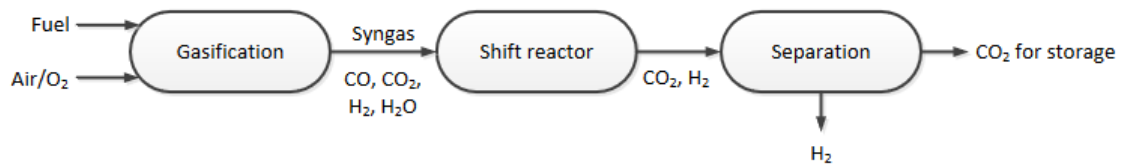

Figure 14 Pre-combustion carbon capture with gasification (IEAGHG 2019)

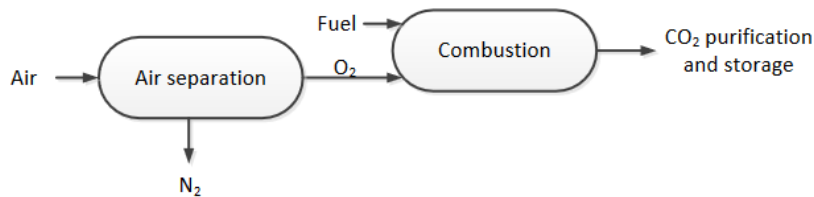

Figure 15 Oxyfuel carbon capture (IEAGHG 2019)

Post-combustion carbon capture means that the carbon dioxide is removed from the flue gases of some sort of combustion process. A post-combustion carbon capture system requires the smallest amount of modification to generic combustion systems, and that is why it is easiest to retrofit to existing plants. However, for example as presented in Table 2, the concentration of CO₂ in flue gases is relatively low, mostly because of high nitrogen amounts

in combustion air, and it needs relatively big amount of energy to operate. (Teir et al. 2011; IEAGHG 2019)

Pre-combustion carbon capture means that the carbon is separated from the fuel before combustion and the fuel is mostly hydrogen. This means that the fuel needs to be gaseous; the system can be used in for example gas-fired power plants and when solid fuel is gasified. Pre-combustion can be applied in a pulp mill for the bark gasification if there is enough hydrogen left to power the lime kiln. (Teir et al. 2011; IEAGHG 2019)

Black liquor gasification (BLG) has been researched since the 1950s as a substitute for combustion in a recovery boiler. Gasification has been seen as a solution for problems like low power-to-heat ratio and thermal efficiency as well as corrosion and fouling. Black liquor gasification has been harnessed in small commercial scale. BLG has been tested for example in New Bern, North Carolina, USA and in Piteå, Sweden, both based on technology developed by a Swedish company called Chemrec AB, and the basic system is presented in Figure 16. (Brown et al. 2008; Gebart et al. 2011; Onarheim et al. 2015)

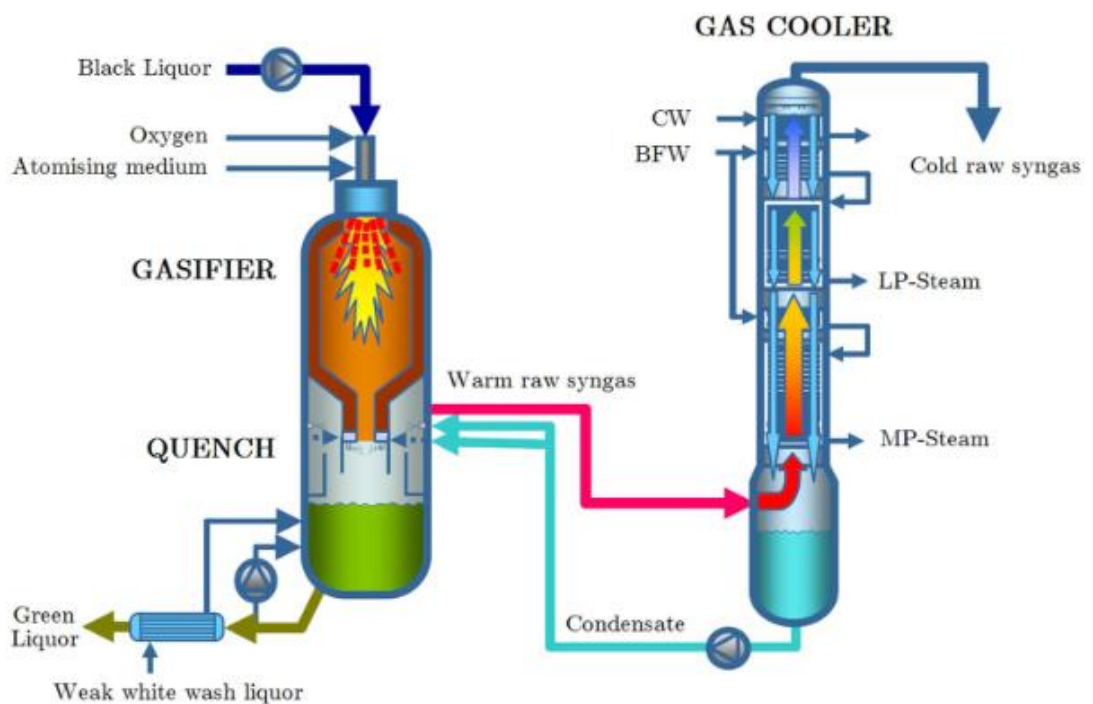

Figure 16 The pressurized, oxygen-blown BLG technology (Onarheim et al. 2015)

Oxyfuel carbon capture means basically that the combustion air is pure oxygen. This way the flue gases have much higher carbon dioxide content, and it is easier to process. However, oxyfuel combustion needs an extra production of oxygen, which is energy consuming. Also, to keep the combustion temperatures reasonable flue gas circulation needs to be introduced. One thing that can be seen as an advantage is that in the pulp mills there is oxygen manufacturing facilities already, however, the dimensioning has not been done for the amounts oxyfuel carbon capture needs. (Teir et al. 2011; IEAGHG 2019; Kuparinen et al. 2019)

6.1 Capturing from flue gas

Some post-combustion carbon capture methods are based on commercial applications that have been used in carbon dioxide and natural gas production for decades, however, they need upscaling for carbon capture in industrial scale. In general, the flue gas needs to be purified before carbon is captured. This means that for example sour components, like NO_x and SO_x , and particles need to be removed and the flue gas needs to be dried. (Teir et al. 2011)

6.1.1 Amine method

The most researched and widely spread method for carbon capture from flue gases is called the amine method. The method is based on chemical solvents absorbing and later releasing the carbon dioxide. Different types of solvents are monoethanolamine (MEA), diethanolamine (DEA), methylethanolamine (MDEA) and ammonia. The solvent can also be a mixture of the aforementioned. A typical layout of an amine-method-based carbon capture system is presented in Figure 17. (Teir et al. 2011)

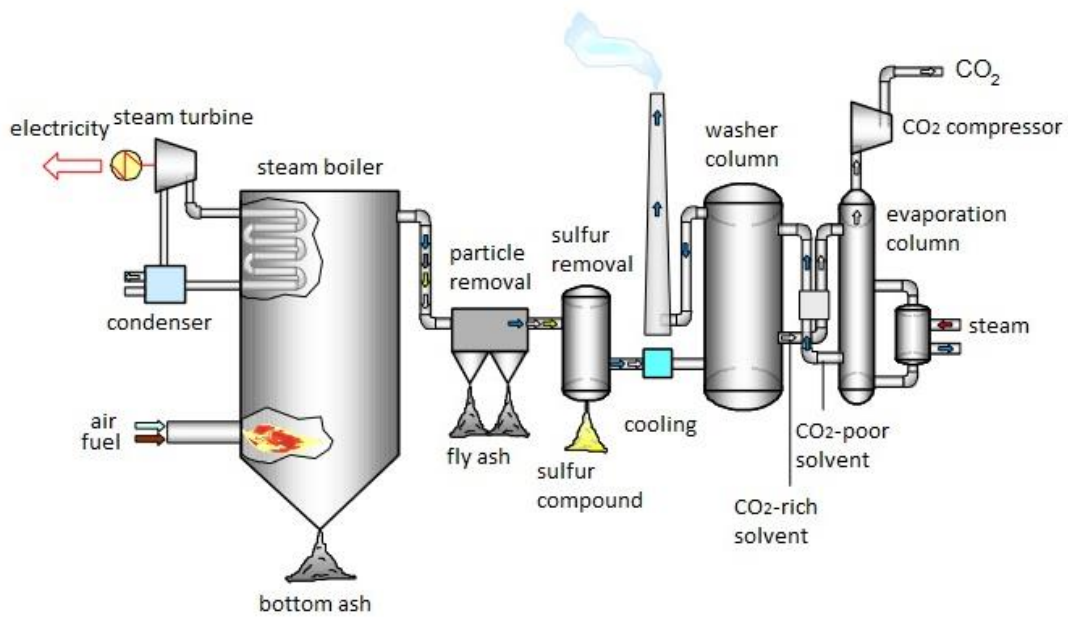

Figure 17 Amine carbon capture from flue gas (Teir et al. 2011)

The amine method is commercially available, and several companies offer carbon capture solutions based on the amine method. The process is also applicable to pre-combustion carbon capture. In Table 3 key values for commercial carbon capture systems are presented. What comes to applying the technologies to existing plants is not only the energy amount needed, but also the needed temperature levels. The desorption happens, depending on the solvent, somewhere between 100 °C and 160 °C, and the energy, transferred via steam or water, needs to be a little bit higher than the desorption temperature used in the specific system. (Rochelle 2012; Onarheim et al. 2015; Kuparinen et al. 2019)

Table 3 Comparative overview of amine-based technologies (IEAGHG 2019)

Technology Supplier	Reboiler Duty [GJ/tCO ₂]	Absorption liquid [m ³ /tCO ₂]	Electricity consumption [kWh/tCO ₂]	Amine/ammonia in exhaust [ppm]	Amine consumption [kg/tCO ₂]
Mitsubishi Heavy Industries	2.6 (coal)	10 (coal)	77 (coal)	Amine: 0.7–3 Ammonia 0.3–2.0	0.35
Shell Cansolv	2.2-2.8 (coal) 2.3-2.9 (gas)	10–16	70 (coal) 100 (goal)	Not found	0.1
Fluor	3.2 (coal) 3.6 (gas)	17	38–40 (coal) 53-125 (gas)	Amine: 0.1–1.0 Ammonia: 1.3–2.2	1.6
Aker Solutions	2.8 (9% CO ₂) 3.4 (gas)	11.4–14.2	Not found	Amine 0.02 Ammonia 0.1	0.2–0.6
BASF-Linde	2.7 (coal)	Not found	22	Amine: 0.3–0.5	0.3
Toshiba	2.4-2.6 (coal)	17	Not found	Not found	Not found
Hitachi	2.4 (coal)	Not found	Not found	Not found	Not found

There are also other notable companies that have industrial scale amine-based carbon capturing systems available in their production, for example Air Liquide. Companies offering amine-based carbon capturing systems usually offer systems for pre- and post-combustion capturing with different carbon dioxide levels, and also, for example, for natural gas purification and carbon capturing from industrial gases. The yearly capturing capacity of the systems is lower than the annual carbon dioxide emissions of a pulp mill, however, it is mentioned that the capacity can be changed by installing the systems parallel. (Mirza & Kearns 2022)

6.1.2 Membrane method

Membrane method means that the separation of gases is done with a permeable film, a membrane. The idea is that carbon dioxide and nitrogen having different size of molecule correctly made membrane is selective enough to separate the gases. The first generation of commercialized membranes for CO₂-selection were cellulose-based, and the next generation membranes are polyimide-based. Also, a big variety of different polymeric materials for

membranes have been presented in the literature, as well as carbon-based membrane research. (He 2016; Scholes 2016; Ji & Zhao 2017; Peters 2023)

There are two things why the membrane method is developed to take over amine method: even though it is not supposed to capture as big percentage of the carbon dioxide as amine method is capable of, it is seen that it can be developed to be more energy efficient, and it also enables a continuous process, whereas amine method is used in batch-based systems. However, membrane systems can be said to far from being commercially used, since they have not reached an energy-efficient state of usage. This is because in general the membrane method needs a significant temperature difference to work, and this combined with the low CO₂ percentage in the flue gas, it takes a large amount of power to operate the fluid machinery to create the needed pressure difference for large flue gas flows. Also, the size of the membrane would be very large in the big power plants and pulp mills. (Merkel et al. 2010; He 2016; Ji & Zhao 2017)

7 Possibilities of utilizing the captured CO₂

After the carbon is captured, something needs to be done with it. To remove the carbon dioxide from the atmosphere permanently, it needs to be stored. Another option is to utilize green electricity to create substitutive fuels for fossil fuels from the captured carbon.

7.1 Storage possibilities

If the aim is to reduce the total carbon dioxide circulating in the atmosphere, it needs to be stored in a way that it doesn't get back to the atmosphere. There are different types of choices of storing carbon dioxide, either underground or under the sea, and a variety of research on alternative methods has been done. Storing carbon into the water column has been researched and is believed to be a possible method. It is banned in the EU due to its negative environmental effects however (Directive 2009/31/EC).

Storing carbon dioxide originates from the enhanced oil recovery (EOR), where it was put to practice purely for economical reason. Carbon dioxide is injected back to the oil well to increase the level of oil that can be reached. A similar method can be used for natural gas. Nowadays, the empty oil and gas fields turn out to be a potential place to store carbon dioxide. (IPCC 2005)

Saline formations offer another large possibility for storing carbon dioxide. They are large, widespread formations of deep sedimentary rocks, filled with formation waters and brines with high salt concentration. Coal seams are suitable for carbon storage as well, since coal, especially immature coal types, like lignite, can absorb gases quite well. However, in coal seams there is often methane, which then would need to be captured. This process is called enhanced coal bed methane (ECBM) recovery. (IPCC 2005)

When carbon dioxide is stored, it needs to be purified and transported to the storage location. The transportation can be done by ship or in a pipe. The price of the transportation among others is a major economical aspect about the total profitability of the whole carbon storage project. Research has been done comparing pipe and ship transportation costs at different distances and quantities of CO₂. Regarding pulp mills, the reality that there is a limited

amount of suitable vessels to carry big amounts of CO₂, as well as the fact that many pulp mills are not easily accessible by waterways, needs to be taken into account. (Kjärstad et al. 2016)

Since most of the plausible CO₂ storages are located in sedimentary basin areas and CO₂ can't be stored at shield areas, Figure 18 makes it clear that CO₂ can't be stored in Finland and needs to be transported. For example, in the research done by Kjärstad et al, ship transport from Finland could be reasonable to the Faludden storage site east of the island of Gotland, Sweden (Kjärstad et al. 2016).

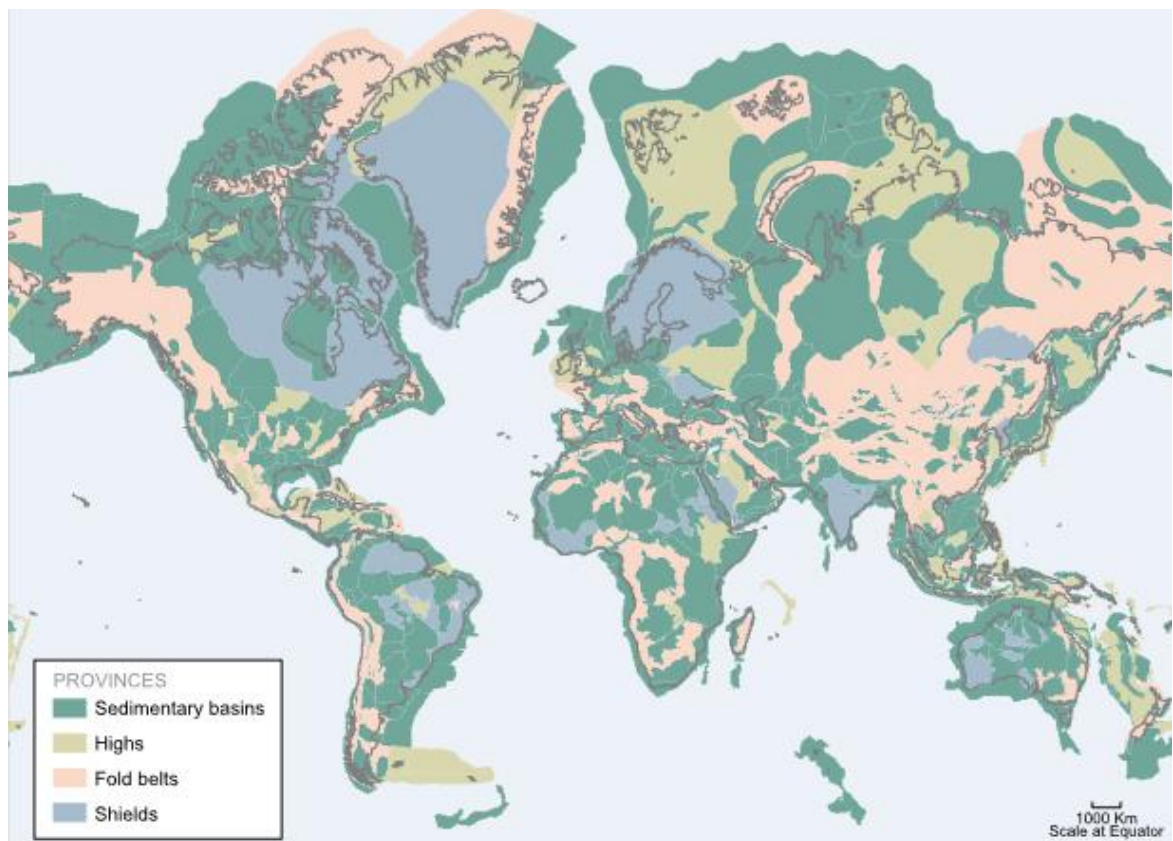

Figure 18 Distribution of sedimentary basins, highs, fold belts and shields (IPCC 2005)

7.2 Power to X

Power-to-X, often P2X, means that power (electricity) is used to create some kind of product. Most of the time the processing starts with electrolysis: electricity is used to separate hydrogen (H_2) and oxygen (O_2) molecules from water (H_2O), as presented in Figure 19.

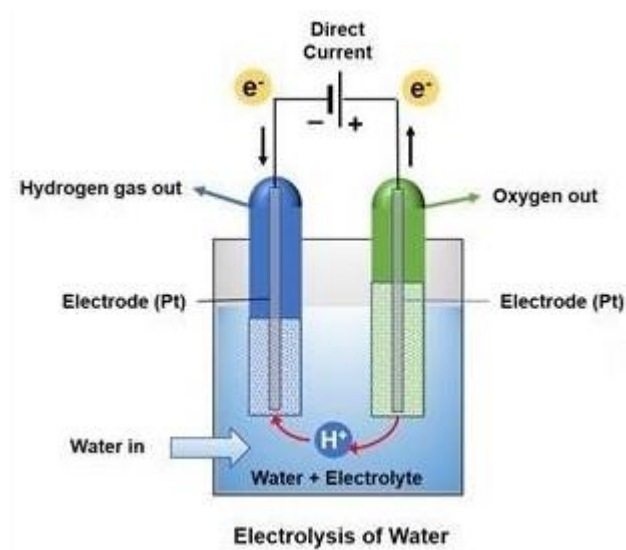

Figure 19 Electrolysis principles (Render & Steyn 2020)

The term P2X can be also more descriptive, referring to the product. The most common ones are P2G (power-to-gas), P2L (power-to-liquid) and P2C (power-to-chemical). (Dahiru et al. 2022)

7.2.1 Outcomes

A P2G system produces gaseous fuel. Most times this fuel is methane (CH_4) and even though the term P2M (power-to-methane) exists, P2G is often understood to mean methane production with the help of electricity. A P2G system can also produce hydrogen and not to process it further. A system producing hydrogen from electricity to be used as a fuel is sometimes also called a P2H₂ system. (Dahiru et al. 2022)

A P2L-process can produce different types of liquid fuels. The most common fuel to be produced is methanol (CH_3OH), but also traffic and aviation fuels can be produced.

Methanol is also occasionally considered as a chemical instead of a fuel, and other common chemicals to be produced in a P2C-process are for example ammonia (NH_3) and formic acid (HCOOH). (Dahiru et al. 2022)

There are several questions that need to be considered when choosing the fuel production system. It needs to be considered, which fuels have large markets, what are the suitable distribution channels and whether it is better to develop the technology at the production site of the fuel or at the usage point. For example, is it better to produce petrol or modify some cars to run on methanol.

Even though synthetic fuels can substitute conventional fuels, often they cannot replace them completely, at least used in today's vehicles, due to their slightly different chemical composition and thus, different combustion properties. However, the intention is often that the final fuel will be a mixture of conventional fuel and synthetic fuel. In the same way, for example methanol can be mixed to conventional fuels to reduce the fossil CO_2 emissions. (Schmidt et al. 2016)

The existing infrastructure might be a crucial factor, when it comes to the decision of what will be the final destiny of the captured carbon dioxide. As presented in Figure 20, there is an existing network for natural gas transmission, which could be most likely used in the pulp mills located nearby, in case the decision is made to produce methane. Electricity can be transferred already, but for example, for carbon dioxide transportation there isn't any large-scale infrastructure. On the other hand, by ship transportation would be plausible for the plants that are close to the Baltic Sea.

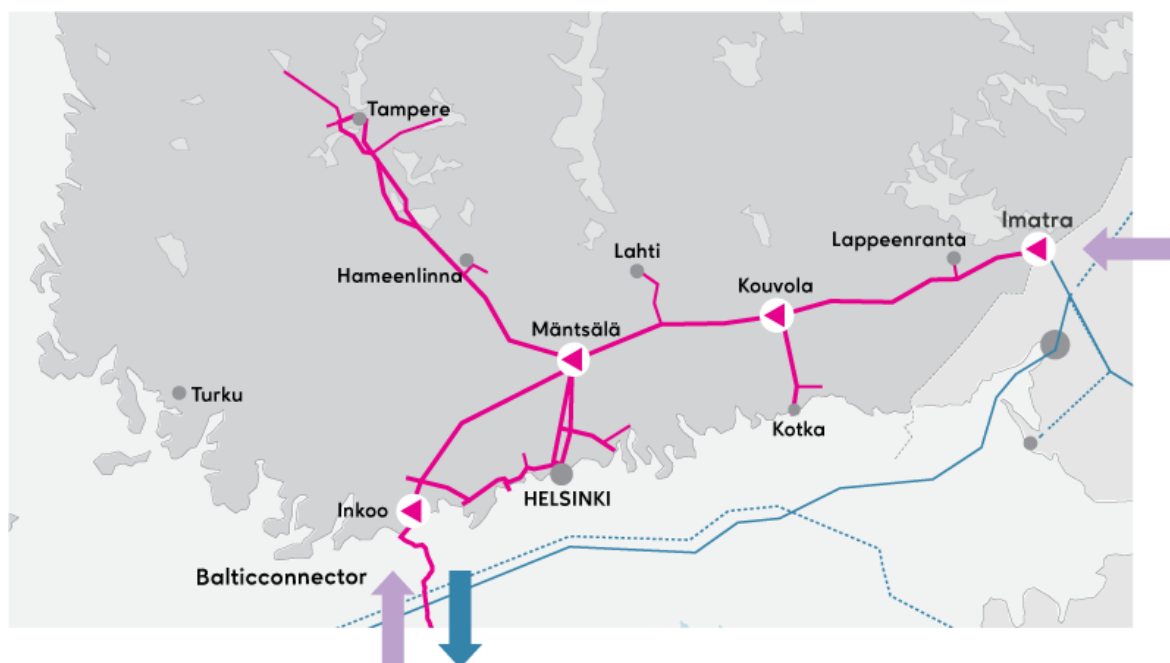

Figure 20 Natural gas transmission network in Finland (Gasgrid 2023)

7.2.2 Processes and their efficiencies

An essential consideration regarding the processes used for carbon capture is that the fact that the process itself needs to produce something including carbon. The main aspect regarding CCU and synthetic fuels in general is the efficiency of the process, and how much electricity justifiable use to get the needed amount of energy in the fuel.

The generation of synthetic fuels starts with hydrogen production. Typically, the highest reached electrolysis efficiencies range from about 75% to 80%, but efficiencies well over 80% have been reached. New technologies are being developed to reach even higher efficiencies (Enkhardt 2015; Hodges et al. 2022). Besides the traditional electrolysis, also known as alkaline water electrolysis (AWE), there are also more advanced electrolysis techniques. Polymer electrolyte membrane (PEM) electrolysis is the most common of those, and PEM electrolyzers are closing reach big industrial scale. (Shiva Kumar & Himabindu 2019)

If the hydrogen is subsequently not already used as a fuel, further refinement is required. This is when the captured CO₂ comes into play. A suitable process is chosen depending on

the type of desired fuel. In general, it can be said that the further the fuel is processed, the more energy is needed and the lower is the total efficiency of the fuel production.

To produce methane, often methanation of carbon dioxide and hydrogen is used. This process is also known as Sabatier reaction or Sabatier process. The process is typically operated with catalysts in temperatures between 200 °C and 500 °C, and in pressures between 10 bar and 30 bar. A typical efficiency of methanation is about 80%, and the efficiency of the whole process of turning carbon dioxide and water into methane would be around 64%. (Schaaf et al. 2014; Stangeland et al. 2017)

Methanol is often seen as a promising synthetic fuel, since it is a relatively good compromise: it is simple from the chemical point of view and it doesn't have the downsides of gaseous fuels, such as low density in atmospheric pressure. Methanol is already an important feedstock in the chemical industry. Traditionally, methanol is produced by steam-reforming natural gas into syngas and then using a copper-based catalyst converting the syngas into methanol. (Rego de Vasconcelos & Lavoie 2019)

To produce methanol from CO₂, a catalytic hydrogenation can be used employing the hydrogen produced during the electrolysis of water. The process is operated in temperatures between 250 °C and 300 °C, and in pressures between 50 bar and 100 bar. In research for large scale CO₂ capturing with methanol production in Germany, an energy demand of slightly less than 10 MWh per tonne of methanol produced was reached (Koytsoumpa et al. 2018). The higher heating value of methanol being 6.39 MWh/tonne and lower heating value (LHV) being 5.54 MWh/tonne, it can be said that the efficiency is quite close to what can be reached when producing methane. (Rego de Vasconcelos & Lavoie 2019)

Methane and methanol, as well as formic acid, can also be produced by electrochemical reduction. It is perceived as a promising technology for developing a high-efficiency process to utilize carbon dioxide. Even though it has already been proven to be a working technology, it is still under development and for example new catalysts are being researched. (Rego de Vasconcelos & Lavoie 2019; Zeng et al. 2022)

The possibility of producing fuels for transportation is always a big point of interest, when talking about P2X. There are two common ways to produce long hydrocarbons, which fuels for transportation mainly consist of: through the Fischer-Tropsch process or from methanol.

During the Fischer-Tropsch process, created by German scientists Franz Fischer and Hans Tropsch back in 1922, the carbon dioxide needs to be converted into carbon monoxide in a reverse water-gas shift reaction (RWGS). Then, the carbon monoxide and hydrogen are processed into hydrocarbons that can then be upgraded into fuels containing longer hydrocarbons, such as petrol, diesel and jet fuel. (Schmidt et al. 2016; Rego de Vasconcelos & Lavoie 2019; Chong & Ng 2021)

Both hydrocarbons and methanol can be upgraded with processes that are already used widely in the chemical industry: for example, hydrocracking, isomerization and distillation can be used to upgrade hydrocarbons and DME synthesis, olefin synthesis, oligomerization, and hydrotreating can be used to upgrade methanol, the used methods depending on the wanted outcome. Both hydrocarbons and methanol can be upgraded into fuels with longer hydrocarbons with efficiencies at roughly 90%. (Schmidt et al. 2016; EASE 2021)

7.3 Carbon dioxide usage at the site

Nowadays, a relatively small amount of carbon dioxide, compared to the amount released from the stack, is used in a pulp mill. Its main usage at pulp mills is in the tall oil production, however, it tall oil is not produced in all pulp mills. The carbon dioxide can be used for pre-neutralizing resin soap. However, later this CO₂ is also released from the process. (Prowledge Oy 2022)

8 Balance calculations of a retrofit carbon capture system

The main goal of the calculation task was to see, if it is possible to retrofit a carbon capture system to an existing pulp mill in terms of energy usage and availability. The calculations were done with IPSEpro heat balance and process modelling software and the pulp mill model used in the calculations was based on the model created by Dr. Jussi Saari that had already been used in a couple of scientific publications (Saari et al. 2020; Saari et al. 2022). The setup was based on a pulp mill integrated with a paper mill, and since the balances were supposed to be calculated for both a pulp-only mill and a pulp and paper integrate, the paper mill was discarded from the integrate to simulate the pulp-only mill. Otherwise, the production numbers, except the electricity production, were kept constant. Since an amine-based method is the only method used in commercial scale applications, it was also chosen for the calculations.

Initially, the pulp producing capacity of the mill was 1 600 000 ADt/a (air-dry tonnes per year) while operating 350 days (8400 hours) per year. With the same number of operating hours the paper production capacity is assumed to be 1 312 500 t/a. The steam was generated by a recovery boiler and a CFB-boiler combusting mostly bark. The fuel power of the recovery boiler was 1054 MW (LHV), and the thermal power of the recovery boiler was 882 MW (LHV). The corresponding values for the CFB-boiler were 276 MW (LHV) and 254 MW (LHV). Both boilers were connected to an individual turbogenerator; the power of the turbogenerator that was powered by the recovery boiler was 128 MWe and the power of the turbogenerator that was powered by the CFB-boiler was 67 MWe.

8.1 IPSEpro model

Modelling the carbon capture system started from the basics, since there were no already made components related to carbon capture available. At first, a very simple unit was made to simulate the heat demand of the system by just determining the heat demand per kilogram of captured CO₂. For this model, an estimation based on the heat consumption values given by the system manufacturers was used. This way it was possible to get a feeling what kind of results should show in the more detailed calculations.

To start the more detailed calculations, an absorber, a desorber, a heat exchanger, an amine cooler and a flue gas drier were made as separate parts for the model combined with a pre-made, two stage flue gas scrubber to harness the heat from the flue gas and to cool down the flue gas for the process. Due to small pressure differences in the system combined with the fact that there was no suitable modelled pump component available in IPSEpro, pressure values were fixed, and pumping energy was not calculated in the model. However, a value of 80 kWh/tCO₂ was used to take into account all the electricity-consuming parts of the capture system.

It was decided that the heat from the flue gas scrubber is used to heat the substitute demineralized water for the system, due to suitable mass flows and temperature levels. The scrubber works with any capturing amount, and it heats the demineralised water and depending on the needed fresh water due to flow levels and condensation losses, with maximum 17.8 MW power. Also, with a heat pump, this heat could be used in a little higher temperature level, but this would mean extra electricity need. An illustrative figure of the CCS system in IPSEpro is presented in Figure 21.

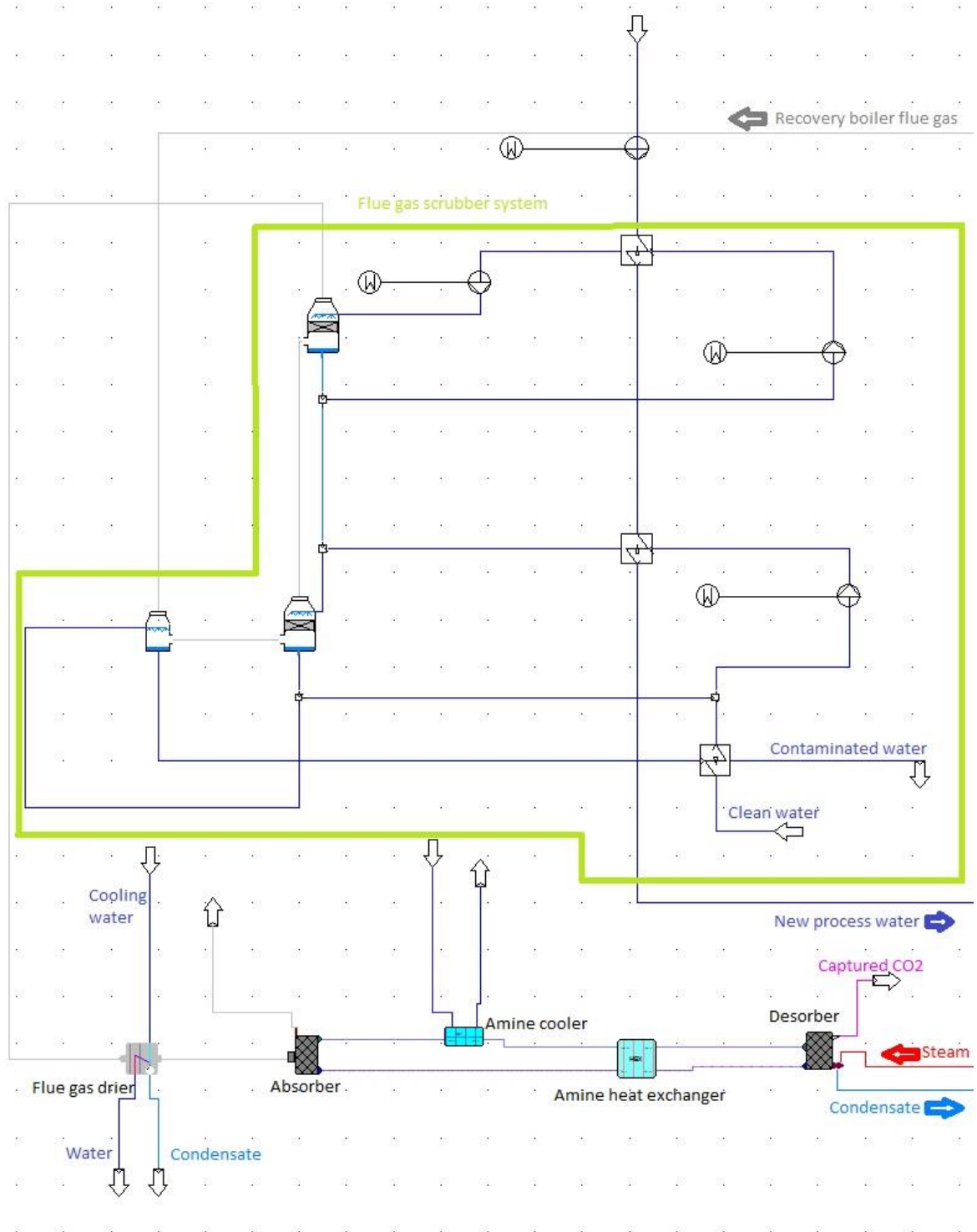

Figure 21 CCS system modelled in IPSEpro

On top of regular mass and enthalpy balances calculated by the program, also extra things were required. Since IPSEpro only calculates balances, enthalpies of absorption and

desorption were added as required input values to the blocks in the absorber and the desorber to simulate the exothermic reaction of carbon dioxide absorption to MEA (monoethanolamine) and the endothermic reaction of carbon dioxide desorption from MEA. Additionally, since IPSEpro doesn't include MEA as a part of chemical composition, ethane was substituted by MEA by telling the program that the mass fraction of MEA was ethane and discarding the enthalpy calculations done by the programs where MEA was present. The enthalpy calculations for MEA were done based on specific heat capacity values with an assumption that the pressure difference in the system doesn't play a significant role.

Initial values used in the calculations were based on several literature sources in a way they were tried to be fitting together as well as possible. The amine-water-mixture contained 30 w-% MEA and 70 w-% water, and the loading of carbon dioxide was chosen to be 0.5 mol/mol MEA. The absorption enthalpy used in the calculations was 86 kJ/mol CO₂ and the desorption enthalpy was -100 kJ/mol CO₂. These values combined with the values for specific heat capacity calculated with the equation presented in Figure 22 resulted in desorber heat demand of 4936 kJ/kg CO₂.

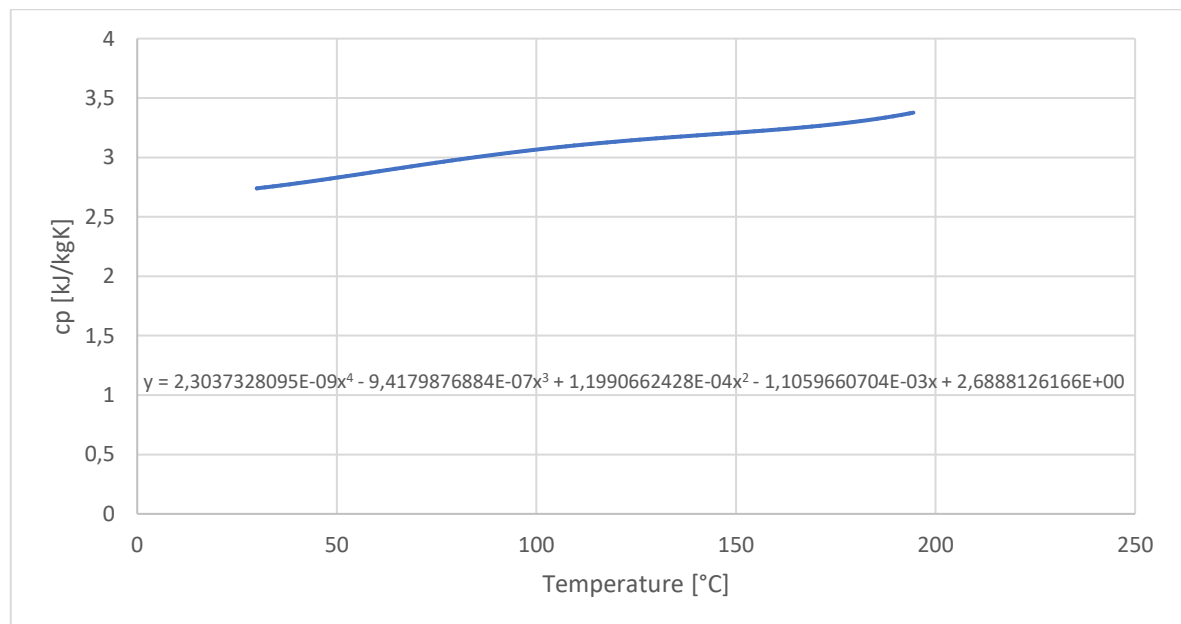

Figure 22 Specific heat capacity equation for MEA (Yaws 2009)

To find reasonable operational values, they were sought from the literature, and it seemed like the values were somewhat secret. However, a nice figure with values used in a similar research was found and the values, especially the temperature levels, were reasonable compared to what were used in other, MEA related publications, so it was used, and the values are presented in Figure 23.

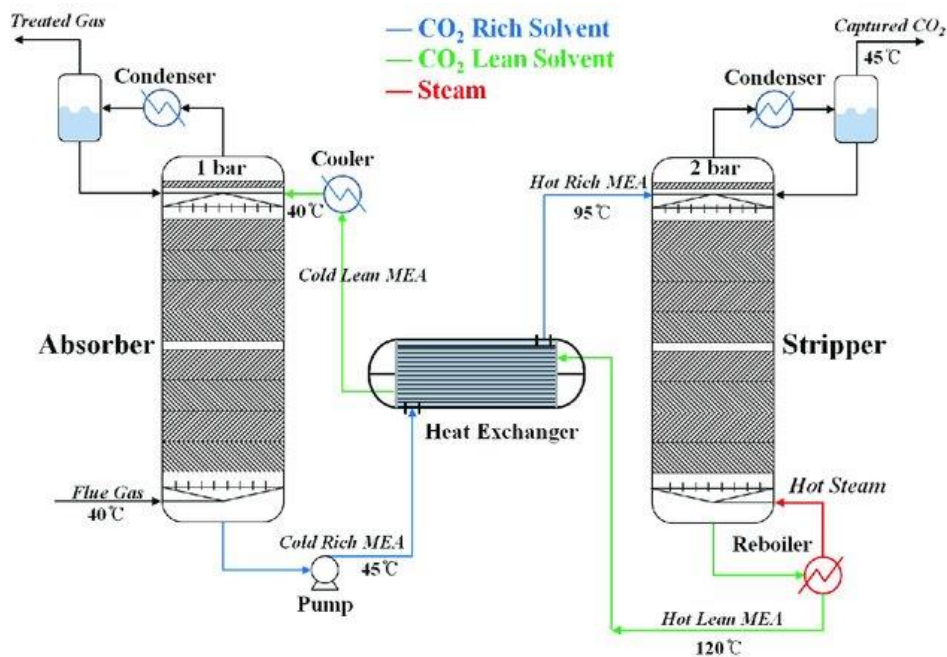

Figure 23 Operational values (Jung et al. 2013)

The heat demand of the system was covered with extraction steam taken from both steam turbines. The extraction steam taken from the larger steam turbine, the steam turbine connected to the recovery boiler, was 5 bars of pressure and 157.53 °C. The equivalent values for the extraction taken from the smaller steam turbine, the steam turbine connected to the CFB boiler, were 5 bars and 170.81 °C. It was decided that the minimum mass flow at the end of the turbine should be 3% of the live steam mass flow at the beginning of the larger turbine, and 5% for the smaller turbine.

Further treatment of the carbon dioxide was not included in the IPSEpro calculation. Based on the chosen technologies and production capacities, the steam requirement for the carbon dioxide treatment processes could be significant. It might also be possible that from the

electricity-intense or largely exothermic processes there would be heat streams worth utilizing. Another thing worth mentioning is that since IPSEpro is program calculating only balances, reaction times in the carbon capture system were not taken into account. Moreover, it was determined that all the carbon dioxide desorbs from the amine in the desorber so that the lean amine going back to the absorber is carbon-dioxide-free.

8.2 Integrated pulp mill

The calculations regarding an integrated pulp mill started by setting the minimum flows at the outlet of the final stage of the turbines as fixed values. This way the program calculated the maximum capture rate for the integrated pulp mill. The capture rate when capturing as much as possible was 0.0683, meaning, that 6.8% of the carbon dioxide emitted from the recovery boiler could be captured. The process values of the flue gas treatment are presented in Figure 24. Since the enthalpy calculation for the amine circulation was not following the programs own equations, the process values were not presented, since they wouldn't be correct in the figure.

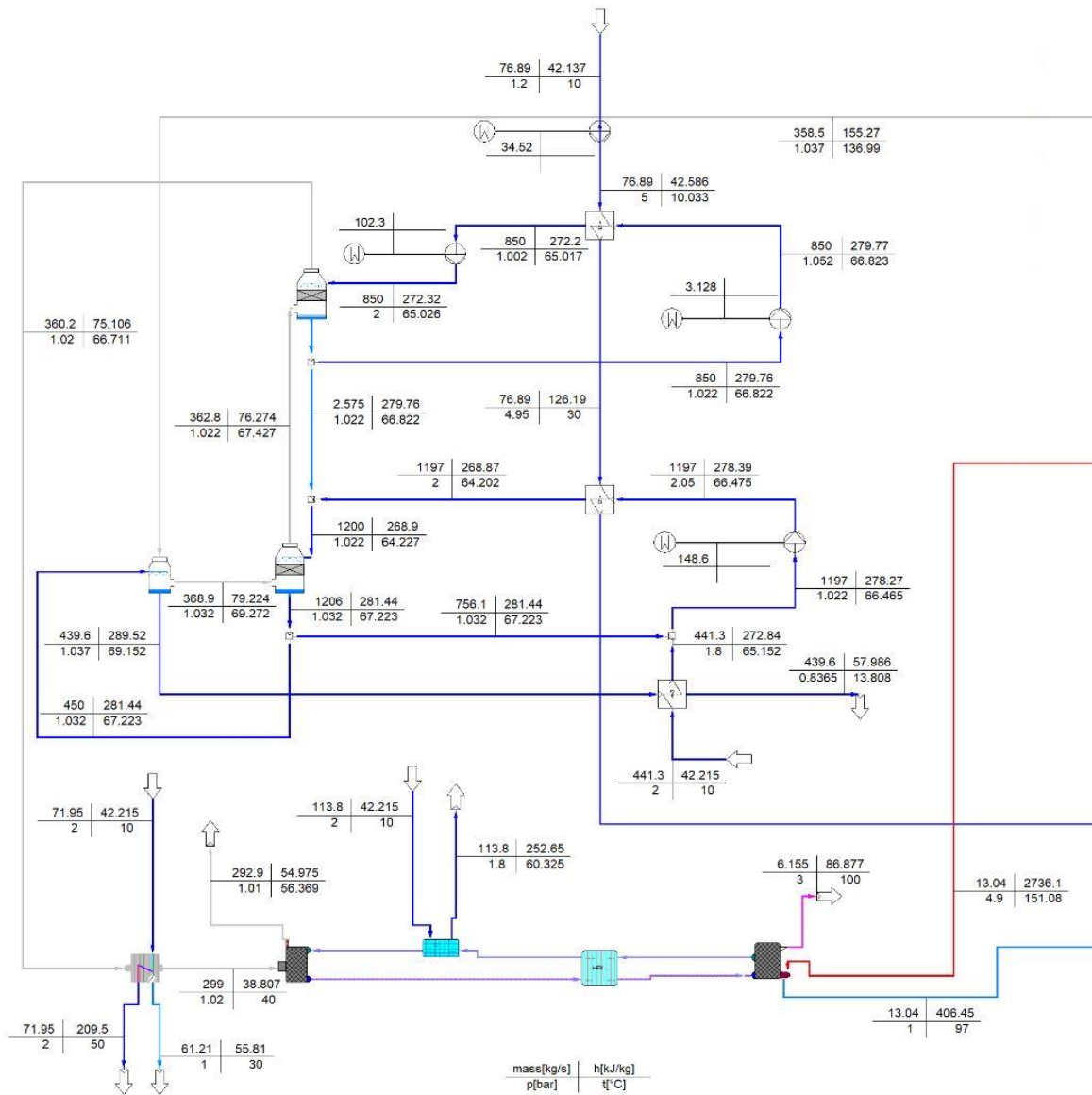

Figure 24 Values of the flue gas treatment system with carbon capture system working at 6.8% capture rate

Next, calculations with different capture amounts were done, and the results are presented in Table 4.

Table 4 Key results of the integrated pulp mill model

Capture rate [%]	0	1	2	3	4	5	6.8
Yearly capture [tCO ₂]	0	27 200	54 500	81 700	108 900	136 200	186 100
Heat demand [MW]	0.0	4.4	8.9	13.3	17.8	22.2	30.4
Net electricity [MW]	179.2	178.0	176.8	175.5	174.4	173.2	171.1
Condenser loss [MW]	46.3	42.9	39.5	36.1	32.7	29.2	22.8

As expected, the net electricity production of the mill goes down when the captured amount of carbon dioxide increases. This is due to two reasons: the system capture system consumes electricity and the more it needs heat as steam, the less steam goes to the final stages of the steam turbines. Also, the less steam goes to the final stages of the steam turbines, the less heat is lost in the condenser, meaning that the carbon capture system partially utilizes waste heat.

8.3 Pulp-only mill

The pulp-only mill was simulated by removing the paper mill from the integrate. This meant that there was significantly more steam available. Similar calculations were done for the mill without paper production as were for the integrated pulp mill. The maximum capture rate was 66.0% which would lead into a significant annual quantity of captured carbon dioxide. The operational values of the system working at this level are presented in Figure 25.

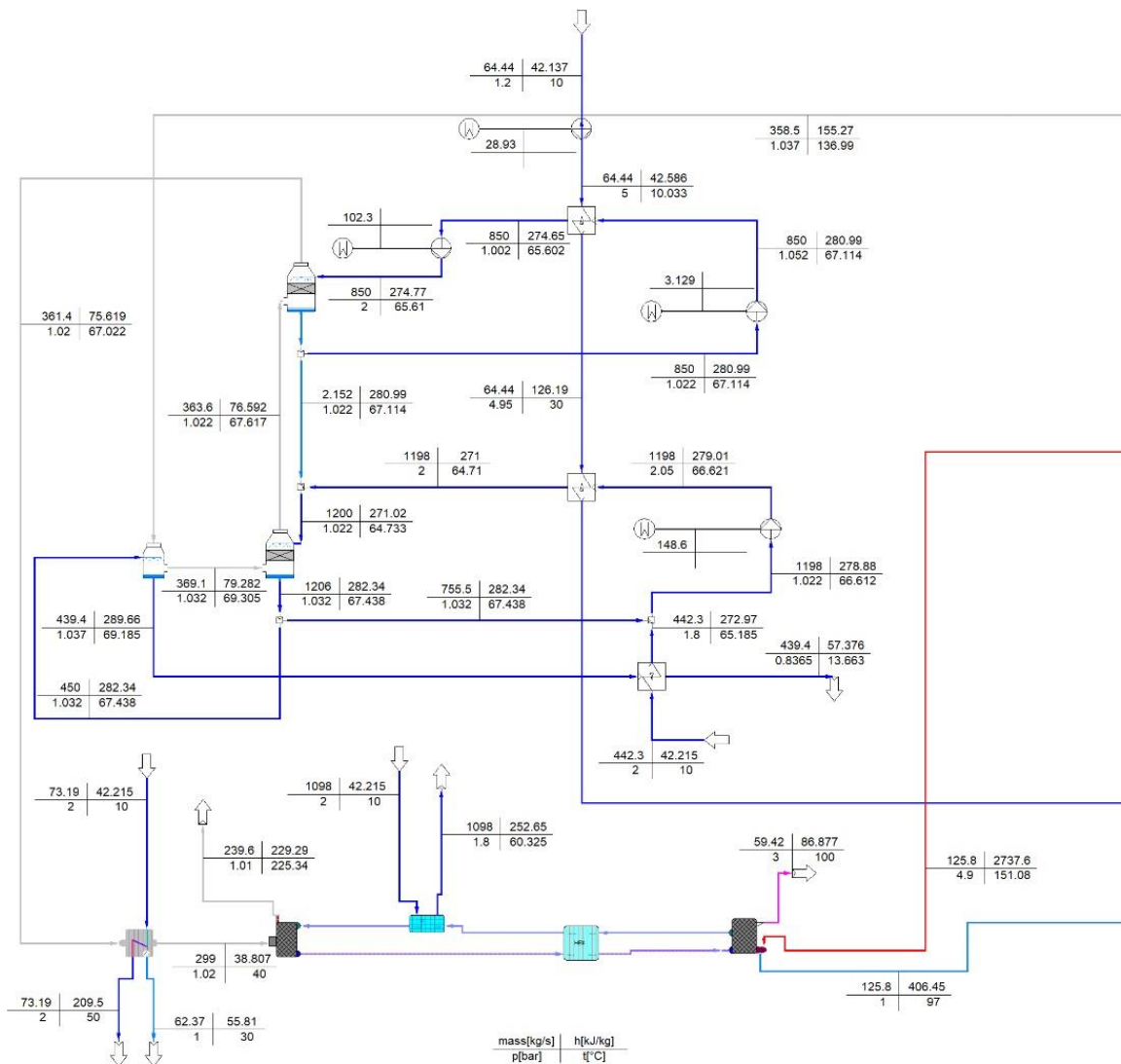

Figure 25 Values of the flue gas treatment system with carbon capture system working at 66.0% capture rate

A paper mill consumes a large amount of steam. This steam being now in the process as leftover, there was a possibility that the model might not work without further changes, especially with the lower capture rates. Results for different levels of carbon capture are presented in Table 5.

Table 5 Key results of the only-pulp mill model

Capture rate [%]	20	30	40	50	60	66
Yearly capture [tCO ₂]	544 700	817 000	1 089 400	1 361 700	1 634 100	1 797 500
Heat demand [MW]	88.9	133.4	177.8	222.3	266.7	293.4
Net electricity [MW]	199.1	197.9	187.6	175.2	164.2	158.2
Condenser loss [MW]	164.4	126.4	97.7	70.8	43.5	22.8

With small capture rates the isentropic efficiency of the last stages of the turbine got very low, and, as we can see from the results, the condenser loss got significant. Other than that, it seems like that it could be possible to have a pulp mill that has a very large carbon capture system, what comes to the amount of steam.

8.4 Improving the performance

The results that were calculated can be said to be comparable mostly to themselves. The heat demand can vary because of several reasons, even due to the program that is used for calculation (Joel et al. 2014).

During the calculation, some testing was done to see, what factors effect on the efficiency. As seen already in some of the references, the initial values given for the MEA system have a significant impact on the results. By increasing the amount of amine in the amine solution and by increasing the carbon dioxide loading a smaller heat demand could be reached, and with that, also a higher maximum capturing capacity. This kind of research has also been done with more accurate research tools (Kim, I. et al. 2014).

Different amines have been researched to see, which would be the best fitting for the amine-based carbon capturing system. MEA is the most widely used, but other options are interesting to reduce the needed energy. Also, the temperature levels of absorption and especially desorption are relevant, since the lower the desorption temperature is, the more likely it is that some waste heat stream could be used to cover the heat demand. (Kim, Y. E. et al. 2013; Gomes et al. 2014)

At some levels of capturing, it might be beneficial to use some live steam to fulfil the heat demand of the capture system, since it was possible in the model. However, the main goal

of the work was to simulate different size scenarios and not to try to optimize the system, so it was decided that at all scenarios all the used steam is taken from the two predetermined extraction points.

Finally, extra steam could be generated in some scenarios, if the capacity of the systems would allow that, for example by adding more fuel to the power boiler. That was simulated as a test with this model by adding 10% extra fuel to see how much the maximum performance of the capture system improves. In the integrated mill the maximum capture rate rose from 6.8% to 11.0%, and in the model that included only the pulp mill the maximum capture rate rose from 66.0% to 70.2%. However, increasing combustion amount when trying to decrease the emissions could be seen as an irresponsible act, since it could be possible to use this fuel to decrease the amount of combusted fossil fuels.

8.5 Improving the calculation system

In the future, the IPSEpro model could also be used to calculate more accurate situations. It would be beneficial to accompany the program with some chemistry modelling program so that more detailed values for the amine circulation could be used. Also, more accurate details about the structure of the carbon capture system might be helpful to create a system that could be fitted and optimized very accurately for a specific system. Different amine solutions, possibilities with heat pumps and varying steam usage could be researched to create a large variety of possible scenarios of when it would be reasonable to fit the mill with a carbon capture system.

9 Investment costs

The system investment calculations were done based on the research report “Feasibility Study for Industrial Pilot of Carbon-Neutral Fuel Production – P2X” performed by Laaksonen et al. at LUT. Further in this chapter, values of this study have been referred as “basis study” or “reference”. The goal of that research project was to see, if it is profitable to capture the carbon dioxide from a cement plant and create synthetic fuels by combining it with excess hydrogen from chlorate production at a plant nearby. In the research report the fuel was refined all the way to gasoline, diesel, kerosene and LPG, however, it was decided that due to the large scale of numbers in this thesis, the final product will be methanol. Also, since both the main raw materials would be produced at the site, storing system costs were not taken into account. (Laaksonen et al. 2021)

9.1 Balance of refining for the investment calculations

The investment calculations of this thesis started by upscaling the production numbers of the basis study, so that the annual production hours would match the plant calculated in this work. Then, it was decided that the same capture rates that were used for the IPSEpro model were also used for the financial calculations. Additionally, a calculation was done for annual capture of 2.2 million tonnes to see, what would be the results for a system that would capture an amount close to the theoretical maximum. This annual capture capacity would equal to capturing 80.8% of the total carbon dioxide emissions.

The big difference between the reference research and calculations done in this thesis is that there wouldn't be hydrogen available at the pulp mills meaning that it would need to be created in electrolysis with electricity. Needed power of the electrolyser is an average calculated with the reported values of two modern, large-scale projects; Neste has planned a 120 MW electrolyser in Porvoo, Finland with a capacity of 48 tonnes of hydrogen per day and Shell has planned a 200 MW electrolyser in Rotterdam, Netherlands (Shell 2022; Keränen 2023).

The production of the systems was scaled up by upscaling the balances of the systems. The fundamentals of the balances for a plant with 3% capture rate are presented in Figure 26 and Figure 27.

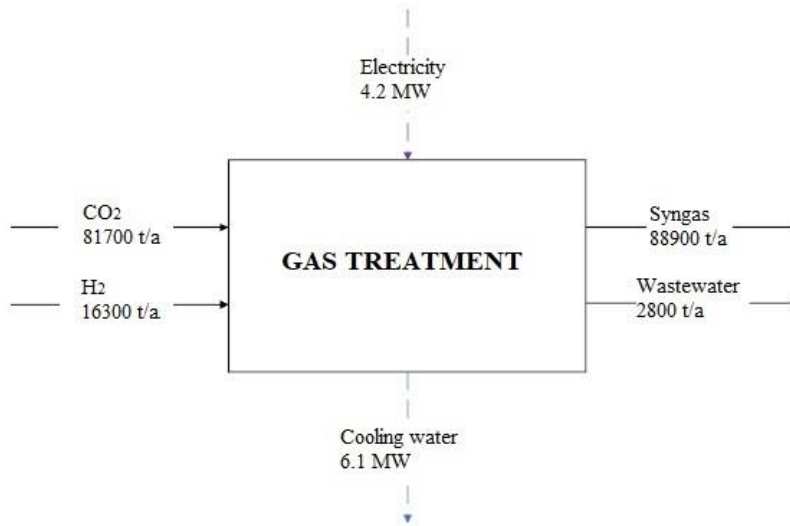

Figure 26 Gas treatment balances (Laaksonen et al. 2021)

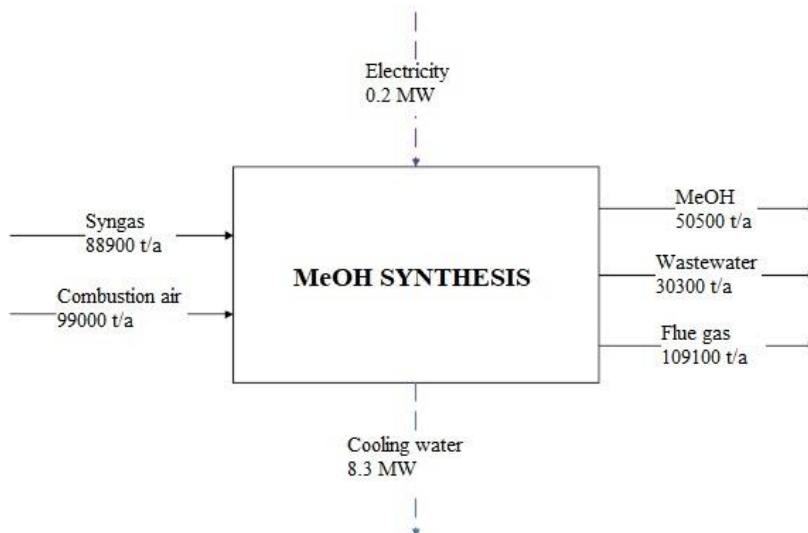

Figure 27 MeOH synthesis balances (Laaksonen et al. 2021)

With this method balance values were calculated for all the chosen capture rates. The results are presented in Table 6 and Table 7.

Table 6 Balance results for MeOH production in the pulp mill integrate, first column being the reference

Capture rate [%]	-	1.0	2.0	3.0	4.0	5.0	6.8
Yearly CO ₂ capture [1000t]	40	27	54	82	109	136	186
Yearly hydrogen need [1000t]	8	5	11	16	22	27	37
Electrolyser power demand [MW]	67	45	91	136	182	227	310
Synthesis power demand [MW]	1.6	1.1	2.2	3.2	4.3	5.4	7.4
Yearly MeOH production [1000t]	26	18	35	53	71	88	121

Table 7 Balance results for MeOH production in the pulp-only mill

Capture rate [%]	20.0	30.0	40.0	50.0	60.0	66.0	80.8
Yearly CO ₂ capture [1000t]	545	817	1089	1362	1634	1798	2200
Yearly hydrogen need [1000t]	109	163	218	272	327	360	440
Electrolyser power demand [MW]	908	1362	1816	2270	2723	2996	3667
Synthesis power demand [MW]	21.6	32.3	43.1	53.9	64.7	71.1	87.1
Yearly MeOH production [1000t]	354	531	707	884	1 061	1 167	1 429

The results show that the presence of an electrolyser might be an insurmountable challenge, due to its immense need of electricity.

9.2 Cost of the systems

The capital cost calculation was based on the cost calculations in Laaksonen et al. (2021) as well. The scaling was done roughly with Equation 1, in which I is investment, 0 is the original value, x is the new value and F is the scaling factor. In this thesis, the scaling factor was chosen to be 0.7.

$$I_x = I_0 \left(\frac{\text{capacity}_x}{\text{capacity}_0} \right)^F \quad (1)$$

Additionally, a price for the electrolyser needed to be found. Comparing to many studies, the price of the electrolyser for the base size was set to 700 000 €/MWe (IRENA 2020; Reksten et al. 2022; IEA 2022b). This price only included the electrolyser itself and the scaling calculation was done in the same way as for the other parts of the plant. This way, the pricing per megawatt for the bigger systems was much lower compared to the values that are presented anywhere in the literature, however, the size is also significantly larger than any system built until this day. On the other hand, it is estimated that in the future the price of the large-scale electrolysers could be significantly cheaper than they are nowadays (Bellini 2022).

In the calculation, first the major equipment costs were calculated, excluding the electrolyser. Then, total costs with ISBL (inside battery limits) costs were estimated by multiplying the equipment costs with the value 3.2, which was simulated with Aspen Process Economic Analyzer in Laaksonen et al. (2021) in similar conditions as the systems considered in this thesis would take place. Then the estimated investment price of the whole electrolyser was added. Finally, these values were multiplied with a value of 1.2 to reflect the recent quick rise of prices, and the value was calculated with the data of conversion rate history of USD to EUR, history of steel prices, industrial building pricing index and Finnish building cost index (Trading Economics 2023; Exchange Rates 2023; FRED 2023; Statistics Finland 2023). The values for the major equipment costs are presented in Table 8 and Table 9, and for the complete systems in Table 10 and Table 11.

Table 8 Major equipment costs for carbon capture system in the pulp mill integrate, first column being the reference

Capture rate [%]	-	1.0	2.0	3.0	4.0	5.0	6.8
Yearly CO ₂ capture [1000t]	40	27	54	82	109	136	186
CO ₂ capture system [M€]	4.3	3.9	6.4	8.4	10	12	15
Gas treatment [M€]	3	3	5	7	8	10	12
MeOH synthesis [M€]	3	2	4	5	6	7	9
Total M€	10	9	15	20	25	29	36

Table 9 Major equipment costs for carbon capture system in the pulp-only mill

Capture rate [%]	20.0	30.0	40.0	50.0	60.0	66.0	80.8
Yearly CO ₂ capture [1000t]	545	817	1089	1362	1634	1798	2200
CO ₂ capture system [M€]	32	42	52	61	69	74	85
Gas treatment [M€]	25	34	41	48	54	58	67
MeOH synthesis [M€]	19	26	31	37	42	44	51
Total [M€]	76	101	124	145	165	176	203

Table 10 Complete system cost estimation in the pulp mill integrate, first column being the reference

Capture rate [%]	-	1.0	2.0	3.0	4.0	5.0	6.8
Yearly CO ₂ capture [1000t]	40	27	54	82	109	136	186
With ISBL costs [M€]	33	30	49	65	79	92	115
Electrolyser [M€]	47	43	70	93	113	132	165
Total [M€]	80	73	118	157	192	225	280

Table 11 Complete system cost estimation in the pulp-only mill

Capture rate [%]	20.0	30.0	40.0	50.0	60.0	66.0	80.8
Yearly CO ₂ capture [1000t]	545	817	1089	1362	1634	1798	2200
With ISBL costs [M€]	244	324	397	464	527	563	649
Electrolyser [M€]	350	464	568	664	754	806	929
Total [M€]	594	789	965	1127	1281	1369	1578

As stated in the previous chapter, the electrolyser is a big electricity consumer. On top of that, it also comes with a big price tag. The calculated prices being rough estimations, it is still clear that the investment costs of the larger systems are enormous. Another thing worth

noticing is that the calculated values do not include the costs of building extra power generation, for example wind power.

In this thesis, cash flows of the new system were not taken into account. In Laaksonen et al. (2021) the net present value with a 20-year calculation time was heavily negative if an electrolyser was chosen to be the source of hydrogen. However, in case there was a situation where there was excess hydrogen available, carbon capturing at a pulp mill would definitely be worth more detailed calculation.

10 Conclusions

Even though the modelling was done only for a specific pulp mill example case, it is likely that other pulp mills would have similar circumstances, regarding the utilization of carbon capture techniques, for example, with the amount of excess heat available. Clear, good results were obtained from the calculations, and it seems like in a large-scale chemical pulp mill a carbon capture system with yearly capture quantity up to scale of 100 000 tonnes of carbon dioxide could be possible. A system this size would need a large, but still reasonably sized electrolyser. Moreover, especially in a situation where there would be hydrogen already available, carbon capturing would be worth a serious consideration.

The calculations made for the pulp mill without paper manufacturing showed that it could be possible to capture a very large quantity of carbon dioxide before the system would use too much heat. However, it could be said that it would be very unlikely that captured carbon dioxide would replace the conventional end products. Also, considering the fact that P2X is often seen as the most desirable way to use the carbon dioxide, the immense amount of electricity needed for the electrolysis would limit the capacity way before the carbon capturing system would use too much heat.

As stated before, one of the most energy consuming parts in an integrated pulp mill is the paper production. While the paper production amounts have gone down within the past couple of years, the cardboard production has increased in demand, and paper machines have been turned into cardboard machines. This trend might keep going and if a process modification project starts anyway, there could be flexibility to balance between carbon capture and end production. However, by looking at the rough profitability estimations, the most likely scenario would be that the production is maximised, and carbon capture technologies could be implemented if there was excess energy to be used.

The literature showed that in general the carbon capture system does benefit from a higher carbon dioxide concentration in the flue gas. Knowing also that the share of total carbon dioxide emissions of a lime kiln is somewhere in the ballpark of 5-10% of the whole pulp mill, it might be a great idea to capture the carbon from the flue gases of the lime kiln, since the carbon dioxide concentration is higher. The decision of the final location would have to

consider additional factors, for example, if one of the flue gas flows would allow cheaper materials to be used in the system.

Money being an important aspect, it seems like political decisions in the European Union are a big differentiating factor whether it is profitable to integrate carbon capture technologies or not. The development of the EU ETS might change the baseline for the price of carbon dioxide emissions, which could either be a good or bad thing for the pulp mills. The products made of the captured carbon could bring financial benefits, but also, the emissions in general could cause financial harm.

In general, it can be said that the studies done in this thesis showed that it would be possible to harness carbon dioxide capture in a Finnish chemical pulp mill. It also showed that the economic and political aspects can be very closely related, and that the future has a lot of open questions. The model created to simulate the system balances could be used, desirably with a little bit more detailed process values of the capturing system, to simulate any individual mill to see, how much carbon dioxide could be captured. However, it seems there are several questions regarding the future to some of which only the time will be able to bring answers.

Bibliography

- Alakangas, E., Hurskainen, M., Laatikainen-Luntama, J. , Korhonen, J., (2016) *Suomessa Käytettävien Polttoaineiden Ominaisuuksia*. VTT Technology 258. Espoo: VTT. ISBN: 9789513884192
- Bellini, E. (2022) *Large scale alkaline electrolyzers may be built at 444/kW in 2030*. [pv magazine International] Retrieved [Apr 19, 2023] Available at: <https://www.pv-magazine.com/2022/02/09/large-scale-alkaline-electrolyzers-may-be-built-at-e444-kw-in-2030/>
- Berglin, N. and Von Schenck, A., (2022) *Biofuels in Lime Kilns - Operating Experience in the Nordic Pulp and Paper Industry*. Stockholm, Sweden: Energiforsk AB. ISBN: 9789176738474
- Biermann, C. J. (1996) *Handbook of Pulping and Papermaking*. San Diego: Academic Press. ISBN: 1281118869
- Blanco, H., Nijs, W., Ruf, J., Faaij, A. (2018) Potential of Power-to-Methane in the EU energy transition to a low carbon system using cost optimization. *Applied Energy* 232: 323-340
- Brown, C., Landälv, I., Stare, R., Yuan, J., DeMartini, N., Ashgriz, N. (2008) *Advancement of High Temperature Black Liquor Gasification Technology*. Federal Way, Washington, USA: Weyerhaeuser Company
- Chong, C. T. and Ng, J., (2021) *Chapter 2 - Biojet fuel production pathways*. In: Chong CT and Ng J (eds) *Biojet Fuel in Aviation Applications*. : Elsevier, 81-141
- Dahiru, A. R., Vuokila, A., Huuhtanen, M. (2022) Recent development in Power-to-X: Part I - A review on techno-economic analysis. *Journal of Energy Storage* 56: 105861
- Degerman, R. (2021) *Stora Enso mieltii Oulun tehtaan toisenkin paperikoneen muuttamista kartonkituotantoon*. [YLE] Retrieved [Feb 14, 2023] Available at: <https://yle.fi/a/3-12152051>
- Department of Energy (2022) *Enhanced Oil Recovery*. Retrieved [Dec 12, 2022] Available at: <https://www.energy.gov/fecm/science-innovation/oil-gas-research/enhanced-oil-recovery>
- Diermann, R. (2023) *RWE bestellt bei Linde zwei 100-Megawatt-Elektrolyseure für Projekt im Emsland*. [pv magazine Deutschland] Retrieved [Feb 10, 2023] Available at: <https://www.pv-magazine.de/2023/01/31/rwe-bestellt-bei-linde-zwei-100-megawatt-elektrolyseure-fuer-projekt-im-emsland/>

Drax (2021) *Drax to invest £40M in next stage of BECCS project*. [Biomass Magazine] Retrieved [Jan 13, 2023] Available at: <https://biomassmagazine.com/articles/18574/drax-to-invest-140m-in-next-stage-of-beccs-project>

EASE (2021) *Power to Methanol/Power to Gasoline — Methanol/Gasoline Synthesis from H₂ and CO₂ by using Water Electrolysis and Post-Combustion Capture*. EASE. Brussels, Belgium: European Association for Storage of Energy

EC (2022a) *Paris Agreement*. [European Commission] Retrieved [16.1., 2023] Available at: https://climate.ec.europa.eu/eu-action/international-action-climate-change/climate-negotiations/paris-agreement_en

EC (2022b) *EU Emissions Trading System (EU ETS)*. [European Commission] Retrieved [Jan 10, 2023] Available at: https://climate.ec.europa.eu/eu-action/eu-emissions-trading-system-eu-ets_en

EC (2022c) *Auctioning*. [European Commission] Retrieved [Jan 11, 2023] Available at: https://climate.ec.europa.eu/eu-action/eu-emissions-trading-system-eu-ets/auctioning_en

EC (2022d) *Market Stability Reserve*. [European Commission] Retrieved [Jan 11, 2023] Available at: https://climate.ec.europa.eu/eu-action/eu-emissions-trading-system-eu-ets/market-stability-reserve_en

EC (2022e) *Carbon leakage*. [European Commission] Retrieved [Jan 11, 2023] Available at: https://climate.ec.europa.eu/eu-action/eu-emissions-trading-system-eu-ets/free-allocation/carbon-leakage_en

EEA (2022a) *European Industrial Emissions Portal*. [European Environmental Agency] Retrieved [Nov 9, 2022] Available at: <https://industry.eea.europa.eu/>

EEA (2022b) *EU Emissions Trading System (ETS) data viewer*. [European Environment Agency] Retrieved [9.1., 2023] Available at: <https://www.eea.europa.eu/data-and-maps/dashboards/emissions-trading-viewer-1>

Ember (2023) *EU Carbon Price Tracker*. Retrieved [Jan 13, 2023] Available at: <https://ember-climate.org/data/data-tools/carbon-price-viewer/>

Energiavirasto (2023) *Päästöoikeuksien ilmaisjako*. Retrieved [Jan 11, 2023] Available at: https://energiavirasto.fi/paastooikeuksien-ilmaisjako#vuodelle_2021_jaetut_paastooikeudet

Engineering ToolBox (2003) *Fuels - Higher and Lower Calorific Values*. Retrieved [Feb 23, 2023] Available at: https://www.engineeringtoolbox.com/fuels-higher-calorific-values-d_169.html

Enkhardt, S. (2015) *Germany: RWE launches power-to-gas plant*. [pv magazine International] Retrieved [Feb 10, 2023] Available at: https://www.pv-magazine.com/2015/08/17/germany-rwe-launches-power-to-gas-plant_100020624/

Erbach, G., Victoria, G. A. (2021) *Carbon Dioxide Removal - Nature-Based and Technological Solutions*. European Parliament: European Parliamentary Research Service. : European Parliament: European Parliamentary Research Service; European Union

ET (2023) *Energiavuosi 2022 - Sähkö*. [Energiateollisuus ry] Retrieved [Jan 17, 2023] Available at: https://energia.fi/files/4428/Sahkovuosi_2022.pdf

Exchange Rates, U. K. (2023) *Euro to US Dollar Spot Exchange Rates for 2023*. [Exchange Rates UK] Retrieved [Mar 15, 2023] Available at: <https://www.exchangerates.org.uk/EUR-USD-spot-exchange-rates-history-2023.html>

Fajardy, M., Pour, N. (2022) *Bioenergy with Carbon Capture and Storage*. IEA. Paris, France: International Energy Agency

Finnish Wind Power Association (2022) *Tuulivoimakartta*. [Suomen Tuulivoimayhdistys ry] Retrieved [Jan 19, 2023] Available at: <https://tuulivoimayhdistys.fi/tuulivoima-suomessa/kartta>

FRED (2023) *Producer Price Index by Industry: New Industrial Building Construction*. [Federal Reserve Bank of St. Louis] Retrieved [Mar 15, 2023] Available at: <https://fred.stlouisfed.org/series/PCU236211236211>

Fridahl, M., Lehtveer, M. (2018) Bioenergy with carbon capture and storage (BECCS): Global potential, investment preferences, and deployment barriers. *Energy Research & Social Science* 42: 155-165

Gasgrid (2023) *Kaasun siirtoverkosto*. [Gasgrid Finland Oy] Retrieved [Feb 27, 2023] Available at: <https://gasgrid.fi/kaasuverkosto/kaasun-siirtoverkosto/>

Gebart, R., Wiinikka, H., Marklund, M., Carlsson, P., Grönberg, C., Weiland, F., Johansson, A., Öhrman, O. G. W. (2011) Recent advances in the understanding of pressurized black liquor gasification. *Cellulose Chemistry and Technology* 45: 521-526

Gomes, J., Santos, S., Bordado, J. (2014) Choosing amine based absorbents for CO₂ capture. *Environmental Technology* 36: 19-25

Google, 2022. [Self-created map of the member plants of the Finnish Recovery Boiler Committee]. Retrieved [Nov 18, 2022]. Available at: <https://www.google.com/maps/d/edit?mid=1cU6jSm0-iTXG59157Mb-VyWW-awP6A0&usp=sharing>

He, X. (2016) *Membranes for CO₂ Capture from Flue Gas*. In: Drioli E and Giorno L (eds) *Encyclopedia of Membranes*. Berlin, Heidelberg: Springer Berlin Heidelberg, 1264-1266

Hodges, A., Hoang, A. L., Tsekouras, G., Wagner, K., Lee, C., Swiegers, G. F., Wallace, G. G. (2022) A high-performance capillary-fed electrolysis cell promises more cost-competitive renewable hydrogen. *Nature Communications* 13(1): 1304

IEA (2022a) *Electrolysers*. [IEA] Retrieved [Apr 18, 2023] Available at: <https://www.iea.org/reports/electrolysers>

IEA (2022b) *Carbon capture, utilisation and storage*. [International Energy Agency] Retrieved [Jan 20, 2023] Available at: <https://www.iea.org/fuels-and-technologies/carbon-capture-utilisation-and-storage>

IEA (2019) *Putting CO₂ to use: Creating Value from Emissions*. Paris, France: International Energy Agency

IEAGHG (2019) Further Assessment of Emerging CO₂ Capture Technologies for the Power Sector and their Potential to Reduce Costs. IEA Greenhouse Gas R&D Programme. Cheltenham, UK: IEA Environmental Projects Ltd.

Ilmatieteen laitos (2009) *Suomen Tuuliatlas*. Retrieved [Jan 19, 2023] Available at: <http://tuuliatlas.fmi.fi/fi/#>

IPCC (2005) *IPCC Special Report on Carbon Dioxide Capture and Storage*. In: Metz B, Davidson O, de Coninck H, Loos M and Meys L (eds) Cambridge, United Kingdom and New York, NY, USA: Cambridge University Press

IRENA (2020) *Green Hydrogen Cost Reduction: Scaling Up Electrolysers to Meet the 1.5°C Climate Goal*. Abu Dhabi, United Arab Emirates: International Renewable Energy Agency

Ji, G. and Zhao, M., (2017) *Membrane Separation Technology in Carbon Capture*. In: Yongseung Yun (ed) *Recent Advances in Carbon Capture and Storage*. Rijeka: IntechOpen, Ch. 3

Joel, A., Wang, M., Ramshaw, C., Oko, E. (2014) Process analysis of intensified absorber for post-combustion CO₂ capture through modelling and simulation. *International Journal of Greenhouse Gas Control* 21: 91–100

Jung, J., Jeong, Y., Lim, Y., Lee, C., Han, C. (2013) Advanced CO₂ Capture Process Using MEA Scrubbing: Configuration of a Split Flow and Phase Separation Heat Exchanger. *Energy Procedia* 37: 1778-1784

Kalliokoski, J. (2022) "Suomalaisen sellun tulevaisuus on valoisa". *Fibre* 2021-2022: 66-67

Keränen, M. (2023) 120 MW elektrolyyseri ja vetyä 2000 kg/h: Neste teki täyskäännöksen ja tähtää nyt vihreän vedyn jättiläiseksi – Tällainen on Suomen ja Euroopan suurten vetyinvestointien tilanne. [Tekniikka&Talous] Retrieved [Apr 19, 2023] Available at: <https://www.tekniikkatalous.fi/uutiset/120-mw-elektrolyyseri-ja-vetya-2000-kg-h-neste-teki-tayskaannoksen-ja-tahtaa-nyt-vihrean-vedyn-jattilaiseksi-tallainen-on-suomen-ja-euroopan-suurten-vetyinvestointien-tilanne/a6c868c5-efc9-449f-bdc3-9eaba49d4717>

- Kim, I., Hoff, K. A., Mejdell, T. (2014) Heat of Absorption of CO₂ with Aqueous Solutions of MEA: New Experimental Data. *Energy Procedia* 63: 1446-1455
- Kim, Y. E., Lim, J., Jeong, S. K., Yoon, Y. i., Bae, S., Nam, S. C. (2013) Comparison of Carbon Dioxide Absorption in Aqueous MEA, DEA, TEA, and AMP Solutions. *Bulletin of the Korean Chemical Society* 34: 783-787
- Kjärstad, J., Skagestad, R., Eldrup, N. H., Johnsson, F. (2016) Ship transport—A low cost and low risk CO₂ transport option in the Nordic countries. *International Journal of Greenhouse Gas Control* 54: 168-184
- Koreneff, G., Suojanen, J., Huotari, P. (2019) *Energy Efficiency of Finnish Pulp and Paper Sector*. VTT-R-01205-19VTT. Espoo: VTT
- Kotkamills (2020) Kotkamills Sustainability Report 2019.
- Kouri, S., Tsupari, E., Kärki, J., Teir, S., Sormunen, R., Arponen, T., Tuomaala, M. (2017) The Potential for CCUS in Selected Industrial Sectors – Summary of Concept Evaluations in Finland. *Energy Procedia* 114: 6418-6431
- Koytsoumpa, E. I., Bergins, C., Kakaras, E. (2018) The CO₂ economy: Review of CO₂ capture and reuse technologies. *The Journal of Supercritical Fluids* 132: 3-16
- Kuparinen, K., Vakkilainen, E., Tynjälä, T. (2019) Biomass-based carbon capture and utilization in kraft pulpmills. *Mitigation and Adaptation Strategies for Global Change* 24(7): 1213-1230
- Kuparinen, K., Lipiäinen, S., Vakkilainen, E., Laukkanen, T. (2023) Effect of biomass-based carbon capture on the sustainability and economics of pulp and paper production in the Nordic mills. *Environment, Development and Sustainability* 25(1): 648-668
- Laaksonen, P., Karjunen, H., Ruokonen, J., Laari, A., Zhaurova, M., Kinnunen, S., Kosonen, A., Kärri, T., Sinkkonen, T., Rissanen, T., Tervonen, A., Varis, J. (2021) *Feasibility Study for Industrial Pilot of Carbon-Neutral Fuel Production – P2X: Final Report*. Lappeenranta, Finland: Lappeenranta-Lahti University of Technology LUT
- Liquid Wind (2022) *FlagshipONE säkrar miljötillstånd för Europas största elektrobränsleanläggning*. Retrieved [Jan 16, 2023] Available at: <https://www.liquidwind.se/news/flagshipone-sakrar-miljotillstand-elektrobransleanlaggning>
- Luke (2023) *Puumassan sekä paperin ja kartongin tuotanto (1000 t) 1955-2021*. [Luonnonvarakeskus] Retrieved [Jan 13, 2023] Available at: https://statdb.luke.fi/PxWeb/pxweb/fi/LUKE/LUKE_04%20Metsa_08%20Muut_Mets_ateollisuus/10.01_Sahatavaran_ja_puulevyjen_tuotanto_1955.px/?rxid=001bc7da-70f4-47c4-a6c2-c9100d8b50db

Luke (2022) *Metsäteollisuuden kotimaisen ja tuontiraakapuun käyttö päätoimialoittain 1860-*. [Luonnonvarakeskus] Retrieved [Nov 21, 2022] Available at: http://statdb.luke.fi/PXWeb/pxweb/fi/LUKE/LUKE_04%20Metsa_04%20Talous_08%20Metsateollisuuden%20puunkaytto/05_metsateol_puunk_toimialoittain_1860.px/?rxid=dc711a9e-de6d-454b-82c2-74ff79a3a5e0

LVM (2020) *Emissions from road transport declining in the 2020s – new measures still needed*. [Ministry of Transport and Communications] Retrieved [Nov 21, 2022] Available at: <https://www.lvm.fi/en/-/emissions-from-road-transport-declining-in-the-2020s-new-measures-still-needed-1167397>

Mäntylä, J. (2023) *Suomessa on tapahtumassa kaikessa hiljaisuudessa vetyvallankumous – katso kartalta, yltääkö vihreä siirtymä kotikuntaasi*. [Yle] Retrieved [Jan 31, 2023] Available at: <https://yle.fi/a/74-20014811>

Merkel, T. C., Lin, H., Wei, X., Baker, R. (2010) Power plant post-combustion carbon dioxide capture: An opportunity for membranes. *Journal of Membrane Science* 359(1): 126-139

Miner, R., Upton, B. (2002) Methods for estimating greenhouse gas emissions from lime kilns at kraft pulp mills. *Energy* 27(8): 729-738

Mirza, N., Kearns, D. (2022) *State of the Art: CCS Technologies 2022*. Global CCS Institute.

Onarheim, K., Arasto, A. (2018) Bio-CCS and Bio-CCU - Climate change mitigation and extended use of biomass raw material. *IEA Bioenergy* 41(05)

Onarheim, K., Garðarsdóttir, S. Ö, Mathisen, A., Nord, L. O. (2015) *Industrial Implementation of Carbon Capture in Nordic Industry Sectors*. : Nordic CCS Competence Centre NORDICCS

Onarheim, K., Santos, S., Kangas, P., Hankalin, V. (2017a) Performance and cost of CCS in the pulp and paper industry part 2: Economic feasibility of amine-based post-combustion CO₂ capture. *International Journal of Greenhouse Gas Control* 66: 60-75

Onarheim, K., Santos, S., Kangas, P., Hankalin, V. (2017b) Performance and costs of CCS in the pulp and paper industry part 1: Performance of amine-based post-combustion CO₂ capture. *International Journal of Greenhouse Gas Control* 59: 58-73

Parkes, R. (2022) *Scrapped | EU's controversial 'additionality' rules for green hydrogen are history after European Parliament vote*. [Recharge] Retrieved [Jan 19, 2023] Available at: <https://www.rechargenews.com/energy-transition/scrapped-eus-controversial-additionality-rules-for-green-hydrogen-are-history-after-european-parliament-vote/2-1-1299195>

Peters, T. (2023) *CO₂ capture with membranes*. [SINTEF] Retrieved [Feb 8, 2023] Available at: <https://www.sintef.no/en/expertise/sintef-industry/sustainable-energy/co2-capture-with-membranes/>

Pirhonen, L. (2022) *Hiilensidonnan markkinat kehittyvät ja kysyntä kasvaa – miten BECCS auttaa saavuttamaan ilmastoneutraaliustavoitteesi?* [Sweco] Retrieved [Jan 16, 2023] Available at: <https://blogs.sweco.fi/kestava-teollisuus/hiilensidonnan-markkinat-kehittyvat-ja-kysynta-kasvaa-miten-beccs-auttaa-saavuttamaan-ilmastoneutraaliustavoitteesi/>

Pisto, V. (2018) *Suomessa muhii jättipotti – tehdas eristi puusta aineen, josta voi tehdä ympäristöystävällisiä maaleja ja liimoja.* [Yle] Retrieved [Jan 16, 2023] Available at: <https://yle.fi/a/3-10098485>

Pohtila, T. (2022) *Uudet tuulivoimaluvat tiukassa itäisessä Lapissa – Puolustusvoimat ei puolla uusia hankkeita alueelle.* [Koti-Lappi] Retrieved [Jan 19, 2023] Available at: <https://www.kotilappi.fi/artikkeli/uudet-tuulivoimaluvat-tiukassa-ita-lapissa-puolustusvoimat-ei-puolla-alueelle-uusia-hankkeita-213832979/>

Prowledge Oy (2022) KnowPulp: Learning Environment for Chemical Pulping and Automation. Espoo: Prowledge Oy, VTT Industrial Systems

Rassool, D. (2019) *Investing in CCS: What do financiers need? -.* [Global CCS Institute] Retrieved [Jan 13, 2023] Available at: <https://www.globalccsinstitute.com/news-media/insights/14285/>

Rego de Vasconcelos, B., Lavoie, J. (2019a) Recent Advances in Power-to-X Technology for the Production of Fuels and Chemicals. *Frontiers in Chemistry* 7(392)

Rego de Vasconcelos, B., Lavoie, J. (2019b) Recent Advances in Power-to-X Technology for the Production of Fuels and Chemicals. *Frontiers in Chemistry* 7(392)

Reksten, A. H., Thomassen, M. S., Møller-Holst, S., Sundseth, K. (2022) Projecting the future cost of PEM and alkaline water electrolyzers; a CAPEX model including electrolyser plant size and technology development. *International Journal of Hydrogen Energy* 47(90): 38106-38113

Render, C. and Steyn, J., (2020) *Hydrogen as Energy Carrier.* [OTC] Retrieved [Feb 9, 2023] Available at: <https://www.ownerteamconsult.com/hydrogen-as-energy-carrier/>

Rochelle, G. T. (2012) Thermal degradation of amines for CO₂ capture. *Current Opinion in Chemical Engineering* 1(2): 183-190

Routa, J., Brännström, H., Hellström, J., Laitila, J. (2021) Influence of storage on the physical and chemical properties of Scots pine bark. *BioEnergy Research* 14(2): 575-587

Saari, J., Peltola, P., Tynjälä, T., Hyppänen, T., Kaikko, J., Vakkilainen, E. (2020) High-Efficiency Bioenergy Carbon Capture Integrating Chemical Looping Combustion with Oxygen Uncoupling and a Large Cogeneration Plant. *Energies* 13(12): 3075

Saari, J., Sermyagina, E., Kuparinen, K., Lipiäinen, S., Kaikko, J., Hamaguchi, M., Mendoza-Martinez, C. (2022) Improving Kraft Pulp Mill Energy Efficiency through Low-Temperature Hydrothermal Carbonization of Biological Sludge. *Energies (Basel)* 15(17): 6188

- Schaaf, T., Grünig, J., Schuster, M. R., Rothenfluh, T., Orth, A. (2014) Methanation of CO₂ - storage of renewable energy in a gas distribution system. *Energy, Sustainability and Society* 4(1): 2
- Schmidt, P., Weindorf, W., Roth, A., Batteiger, V., Riegel, F. (2016) *Power-to-Liquids: Potentials and Perspectives for the Future Supply of Renewable Aviation Fuel*. Dessau-Roßlau, Germany: German Environment Agency
- Scholes, C. A. (2016) *Carbon Dioxide (CO₂) Separation by Membranes*. In: Drioli E and Giorno L (eds) *Encyclopedia of Membranes*. Berlin, Heidelberg: Springer Berlin Heidelberg, 299
- Schönberg, K. (2021) *EU:n suojeluvaatimus voi iskeä raskaasti Suomen metsäteollisuuteen: uhkana puupula*. [YLE] Retrieved [Jan 18, 2023] Available at: <https://yle.fi/a/3-12231175>
- Shahin, H., Hassanpour, S., Saboonchi, A. (2016) Thermal energy analysis of a lime production process: Rotary kiln, preheater and cooler. *Energy Conversion and Management* 114: 110-121
- Shell (2022) *Shell to start building Europe's largest renewable hydrogen plant*. [Shell] Retrieved [Apr 19, 2023] Available at: <https://www.shell.com/media/news-and-media-releases/2022/shell-to-start-building-europes-largest-renewable-hydrogen-plant.html>
- Shiva Kumar, S., Himabindu, V. (2019) Hydrogen production by PEM water electrolysis – A review. *Materials Science for Energy Technologies* 2(3): 442-454
- Sieppi, S. (2021) Neste to receive funding from the EU Innovation Fund to develop its Porvoo refinery through green hydrogen production and carbon capture & storage. [NESTE] Retrieved [Jan 18, 2023] Available at: <https://www.neste.com/releases-and-news/innovation/neste-receive-funding-eu-innovation-fund-develop-its-porvoo-refinery-through-green-hydrogen>
- Smook, G. A. (2016) *Handbook for Pulp & Paper Technologists (4th Edition)*. Peachtree Corners, Georgia, USA: TAPPI. ISBN: 9781595102454
- Stangeland, K., Kalai, D., Li, H., Yu, Z. (2017) CO₂ Methanation: The Effect of Catalysts and Reaction Conditions. *Energy Procedia* 105: 2022-2027
- Statistics Finland (2023) *118p -- Building cost index by type of cost, monthly data, 1990M01-2023M03*. [Statistics Finland] Retrieved [Mar 15, 2023] Available at: https://pxdata.stat.fi/PxWeb/pxweb/en/StatFin/StatFin_rki/statfin_rki_pxt_118p.px/
- Steyn, M., Oglesby, J., Turan, G., Pinto, E., Rassool, D., Williams, E., Consoli, C., Minervini, J., Zapantis, A., Gebremedhin, R., Al Amer, N., Havercroft, I., Ivory-Moore, R., Xiaoliang, Y., Abu Zahra, M. (2022) *Global Status of CCS 2022* Global CCS Institute. Melbourne, Australia: Global CCS Institute

Tampereen Sähkölaitos (2023) *Hiilidioksidin talteenotto*. Retrieved [Jan 18, 2023]
Available at: <https://www.sahkolaitos.fi/yrityksille-ja-taloyhtioille/lamporatkaisut/hiilidioksidin-talteenotto-ja-hyodyntaminen/>

Teir, S., Pikkarainen, T., Kujanpää, L., Tsupari, E., Kärki, J., Arasto, A., Aatos, S., (2011) *Hiilidioksidin Talteenotto Ja Varastointi (CCS) - Teknologia katsaus*. VTT Working Papers 161. Espoo: VTT. ISBN: 978-951-38-7503-9

Theliander, H. (2009) The Recovery of Cooking Chemicals: the White Liquor Preparation Plant. *Pulping Chemistry and Technology* 2(13): 335-362

Tikka, P. (2008) Papermaking Science and Technology. Book 6, Chemical Pulping. Part 2, Recovery of Chemicals and Energy. Helsinki: Finnish Paper Engineers' Association. ISBN: 978-952-5216-26-4

Tiseo, I. (2022) *Global consumption of paper and cardboard 1961-2021*. [Statista] Retrieved [Jan 13, 2023] Available at: <https://www.statista.com/statistics/270319/consumption-of-paper-and-cardboard-since-2006/>

Toivonen, J. (2022) EU ei kiellä metsän hakkaamista lämmitysenergiaksi, mutta uusiutuvan energian tuet saattavat kadota – uusi direktiivi on täynnä eturistiriitoja. [YLE] Retrieved [Jan 18, 2023] Available at: <https://yle.fi/a/3-12625042>

Trading Economics (2023) *Steel*. [TRADING ECONOMICS] Retrieved [Mar 15, 2023] Available at: <https://tradingeconomics.com/commodity/steel>

Vaara, K. (2021) Paperin kulutus kasvaa, mutta Suomen tehtaat eivät pääse siihen kiinni – viennin lähitulevaisuus on alhaisen jalostusasteen sellun varassa. [YLE] Retrieved [13.1., 2023] Available at: <https://yle.fi/a/3-11818464>

Vakkilainen, E. K. (2017) *Steam Generation from Biomass - Construction and Design of Large Boilers*. Oxford: Elsevier. ISBN: 012804389X

Vakkilainen, E. K. (2005) *Kraft Recovery Boilers – Principles and Practice*. Helsinki: Suomen Soodakattilayhdistys r.y.

Yaws, C. L. (2009) *Yaws' Handbook of Thermodynamic Properties for Hydrocarbons and Chemicals*. New York, New York, United States: Knovel. ISBN: 9781601197979

Zeng, J., Castellino, M., Fontana, M., Sacco, A., Monti, N. B. D., Chiodoni, A., Pirri, C. F. (2022) Electrochemical Reduction of CO₂ With Good Efficiency on a Nanostructured Cu-Al Catalyst. *Frontiers in Chemistry* 10

Zuo, W., Zhang, X., Li, Y. (2020) Review of flue gas acid dew-point and related low temperature corrosion. *Journal of the Energy Institute* 93(4): 1666-1677

Directives and regulations

VNS 6/2022 vp *Hiilineutraali Suomi 2035 - kansallinen ilmasto- ja energiastrategia.*

(2022a) Available at:

https://www.eduskunta.fi/FI/vaski/KasittelytiedotValtiopaivaasia/Sivut/VNS_6+2022.aspx

VNS 4/2022 vp *Keskipitkän aikavälin ilmastopolitiikan suunnitelma - Kohti hiilineutraalia yhteiskuntaa 2035.* (2022b) Available at:

https://www.eduskunta.fi/FI/vaski/KasittelytiedotValtiopaivaasia/Sivut/VNS_4+2022.aspx

Directive 2009/31/EC of the European Parliament and of the Council of 23 April 2009 on the geological storage of carbon dioxide and amending Council Directive 85/337/EEC, European Parliament and Council Directives 2000/60/EC, 2001/80/EC, 2004/35/EC, 2006/12/EC, 2008/1/EC and Regulation (EC) No 1013/2006. (2019) Available at:

<http://data.europa.eu/eli/dir/2009/31/oj>

Directive (EU) 2018/2001 of the European Parliament and of the Council of 11 December 2018 on the promotion of the use of energy from renewable sources (2018a) Available at:

<http://data.europa.eu/eli/dir/2018/2001/oj>

Directive (EU) 2018/410 of the European Parliament and of the Council of 14 March 2018 amending Directive 2003/87/EC to enhance cost-effective emission reductions and low-carbon investments, and Decision (EU) 2015/1814. (2018b) Available at: [https://eur-](https://eur-lex.europa.eu/eli/dir/2018/410/oj?locale=en)

[lex.europa.eu/eli/dir/2018/410/oj?locale=en](https://eur-lex.europa.eu/eli/dir/2018/410/oj?locale=en)

Directive 2009/31/EC of the European Parliament and of the Council of 23 April 2009 on the geological storage of carbon dioxide and amending Council Directive 85/337/EEC, European Parliament and Council Directives 2000/60/EC, 2001/80/EC, 2004/35/EC, 2006/12/EC, 2008/1/EC and Regulation (EC) No 1013/2006. (2009) Available at:

<http://data.europa.eu/eli/dir/2009/31/oj>